

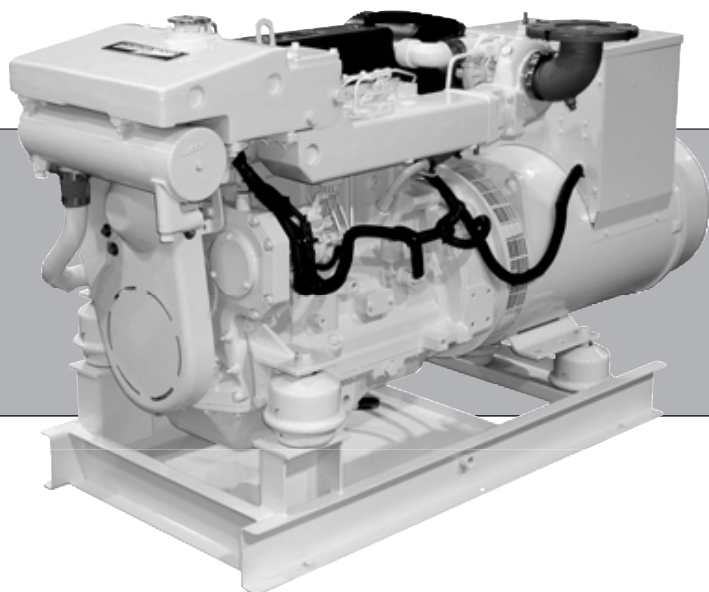

PARTS MANUAL

P1064

For Models: L1064D, L1064A, M1064D, M1064T1, M1064T2,
M1064A, M1064H, NL1064D, NL1064T1, NL1064T2,
NL1064H1, NL1064H2, M40C2, M55C2 and M65C2



www.northern-lights.com



— CALIFORNIA —
Proposition 65 Warning:

Diesel engine exhaust and some of its constituents are known to the State of California to cause cancer, birth defects, and other reproductive harm.

Northern Lights
4420 14th Avenue N.W.
Seattle, WA 98107
Tel: (206) 789-3880
Fax: (206) 782-5455

Copyright ©2017 Northern Lights, Inc.
All rights reserved. Northern Lights™, and
the Northern Lights logo are trademarks of
Northern Lights, Inc.

Printed in U.S.A.
PART NO.: P1064 12/18



PARTS CATALOG

for Models

L1064D, L1064A, L1064T1, M1064D, M1064T1, M1064T2, M1064A, M1064H,
NL1064D, NL1064T1, NL1064T2, NL1064H1, NL1064H2, M40C2, M55C2, and M65C2

Please read thoroughly before attempting to use this manual:

Table of Content.....	I
Model Designation & Serial Numbers.....	II
Reading a Parts Page.....	III

Table of Contents

GROUP 1 - ENGINE

Cylinder Block Assembly.....	0- 5
Flywheel Housing	6- 9
Crankshaft & Main Bearings.....	10
Crankshaft Pulley.....	11- 13
Cylinder Liner Assembly & Connecting Rod....	14- 17
Timing Cover Plate	18- 21
Camshaft	22- 23
Balance Shaft	24- 25
Timing Cover	26- 29
Oil Filter Assembly, Mounting, & Adapter	30- 34
Oil Pump.....	35
Oil Pan	36- 38
Oil Drain & Dipstick.....	39- 41
Oil Fill Assembly	42- 43
Low Oil Level Switch/Gauge	44 - 45
Cylinder Head, Head Gasket, Valves	46- 49
Rocker Cover, Rocker Shaft, Rocker Arm.....	50- 59
Ventilating System	59

GROUP 2 - INTAKE & EXHAUST

Intake Manifold and Air Cleaner.....	0- 1
Air Intake & Turbocharger.....	2- 5, 14- 17, 20- 21
Air Intake & Air Filter	6- 7, 22- 23
Intake & Aftercooler.....	12- 13, 18- 19
Crankcase Breather	8- 11, 24- 25
Intake Manifold & Air Filter (Industrial)	26- 35
Exhaust Manifold & Adapter.....	36- 39, 43- 44
Exhaust Elbows.....	40- 42, 47
Turbocharger Assemblies.....	45- 46, 52- 53
Exhaust Adapter (Industrial).....	48- 50

GROUP 3 - COOLING SYSTEM

Expansion Tank Assembly.....	0- 3
Heat Exchanger	4- 7
Coolant Pump Inlet & Assembly	8- 10
Raw Water Pump & Mounting.....	11- 14
Thermostat Housing	15- 17

Oil Cooler.....	18
Idler Shaft.....	19- 21
Radiator.....	22- 25

GROUP 4 - FUEL SYSTEM

Fuel Injection Pump & Fuel Lines	0- 17
Injection Pump Applications	18
Engine Control Unit Applications	19
Fuel Injectors	20- 25
Fuel Filter & Lines.....	26- 31
Fuel Supply & Return Connections.....	32- 34
Fuel Filters	35- 36
Fuel Filter Bypass	37- 38
Fuel Transfer Pump.....	39- 41
Throttle.....	42

GROUP 5 - ELECTRICAL SYSTEM

12 & 24 Volt, Standard & Isolated Ground	0- 31
Oil Pressure Manifold.....	32
Stop Solenoid, Cold Start Sensor & Solenoid ...	33- 35
Alternators and Mounting	36- 49
Circuit Breaker, Relay Panels, DC Enclosure....	50- 55
Drive Belt and Tensioner	56- 57, 59
Idler Pulley & Mounting.....	58
Control Panels 12 & 24 Volt	60- 72
Remote Alarm	73
Belt Guards	74- 89

GROUP 6 - GASKET SETS

Engine Overhaul.....	0- 4
----------------------	------

GROUP 7 - GEAR AND ADAPTER PARTS

Gear Oil Cooler	1- 3
-----------------------	------

GROUP 8 - FRAMES & MOUNTING

Base Frames.....	1- 11
------------------	-------

GROUP 9 - ACCESSORIES & OPTIONAL EQUIPMENT

Low Coolant Level Switch	0- 1
Raw Water Flow Switch	2- 7
Governor Actuator & Mounting.....	8
Electric Clutch & PTO Assembly	

Proprietary Information

This publication is the property of Northern Lights, Inc.

It may not be reproduced in whole or in part without the written permission of Northern Lights, Inc.

© Northern Lights, Inc. All rights reserved. Litho U.S.A. Publication number P1064 6/17

INTRODUCTION

MODEL DESIGNATION

Refer to the category designations below to find the correct parts pages for your model.

L - M - NL

- L** - Lugger propulsion unit
- M** - Northern Lights marine generator set
- NL** - Northern Lights industrial generator set

1064

Base Model #
(Deere 4045 Powertech
Series engine block)

D - T - A - H - C

- | | |
|----------------|---------------|
| Aspiration | A Aftercooled |
| D Natural | H High Output |
| T Turbocharged | C Commercial |

- L 1064 D** = Northern Lights naturally aspirated propulsion engine with a John Deere 4045 engine.
- M 1064 D** = Northern Lights naturally aspirated marine diesel generator with a John Deere 4045 engine.
- M 1064 T** = Northern Lights turbocharged marine diesel generator set with a John Deere 4045 engine.
- M 1064 A** = Northern Lights turbocharged marine diesel generator set with a John Deere 4045 engine, aftercooled.
- M 1064 H** = Northern Lights turbocharged high output marine diesel generator set with a John Deere 4045 engine.
- MP 40 C2** = Northern Lights naturally aspirated marine diesel generator set with a John Deere 4045 engine, 40 kW.
- MP 55 C2** = Northern Lights turbocharged marine diesel generator set with a John Deere 4045 engine, 55 kW.
- MP 65 C2** = Northern Lights turbocharged marine diesel generator set with a John Deere 4045 engine, 65 kW.
- NL 1064** = Northern Lights industrial diesel engine, with a John Deere 4045 engine.

All model numbers in parentheses will indicate a John Deere base engine. All variations requiring serial numbers for proper identification will be noted as Northern Lights or John Deere.

SERIAL NUMBERS

NORTHERN LIGHTS

Your set has three serial numbers: ① an engine number stamped on the block, ② a generator plate, and ③ a generator set plate. Use the serial number on the **generator set plate** when ordering parts or in correspondence. The generator set plate is found on the service side of the generator and resembles one of the drawings below.

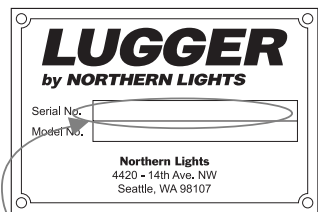

Lugger Serial Number

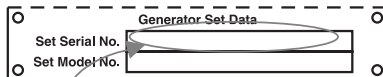
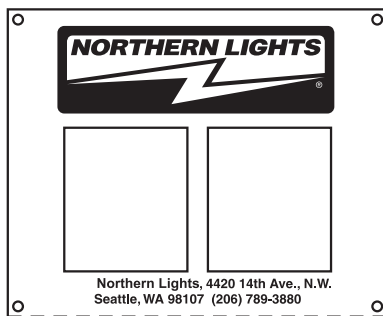

Generator Set Serial Number



Generator Set Serial Number

READING A PARTS PAGE

IMPORTANT:

Before selecting parts, be sure that you are choosing parts from the correct page. Check the model designation at the page top. Do not use this illustration for parts purchasing.

1 — ELECTRICAL SYSTEM

ALTERNATOR ASSEMBLY: M - NL445

KEY	PART NUMBER	QTY.	DESCRIPTION	SERIALNUMBER
0	185046210	1	Alternator Assembly	-
1	185446219	1	Flywheel, complete	-
2	185446217	1	Plate, complete	-
3	185716200	1	Plate	-
4	185446218	1	Stator, complete	-
5	040126210	2	Bearing	-
6	020210010	1	Nut	-
7	027100010	1	Spring washer	-
8	026100010	1	Washer	-
9	185446220	1	Clamp	-
10	015140408	1	Screw	-
11	015140425	2	Screw	-
12	199236510	1	Collar	-

13 — P445 06/00 — 14
11 — 5-2 — 12

REFERENCES:

- | | |
|--|--|
| <ol style="list-style-type: none"> 1. Grouping section title. 2. Model designation of equipment that uses parts listed on this page. 3. Title and description of assembly. 4. Drawing numbers that correspond to key column numbers for parts identification. 5. Key column for locating parts shown on drawing. 6. Part number. | <ol style="list-style-type: none"> 7. Quantity of parts used. 8. Description of each component part. 9. Serial number of unit the part fits. 10. Assembly or kit designated by Key 0 or ••/•. 11. Grouping index number. 12. Page number within the grouping index. 13. Manual title. 14. Page publication date. |
|--|--|

NOTE: ⇨ Arrows always point toward the front of the engine.

Cylinder Block

L-M-NL1064D, M-NL1064T1-T2, L-M1064A, NL1064H1, M40C2, M55C2, & M65C2

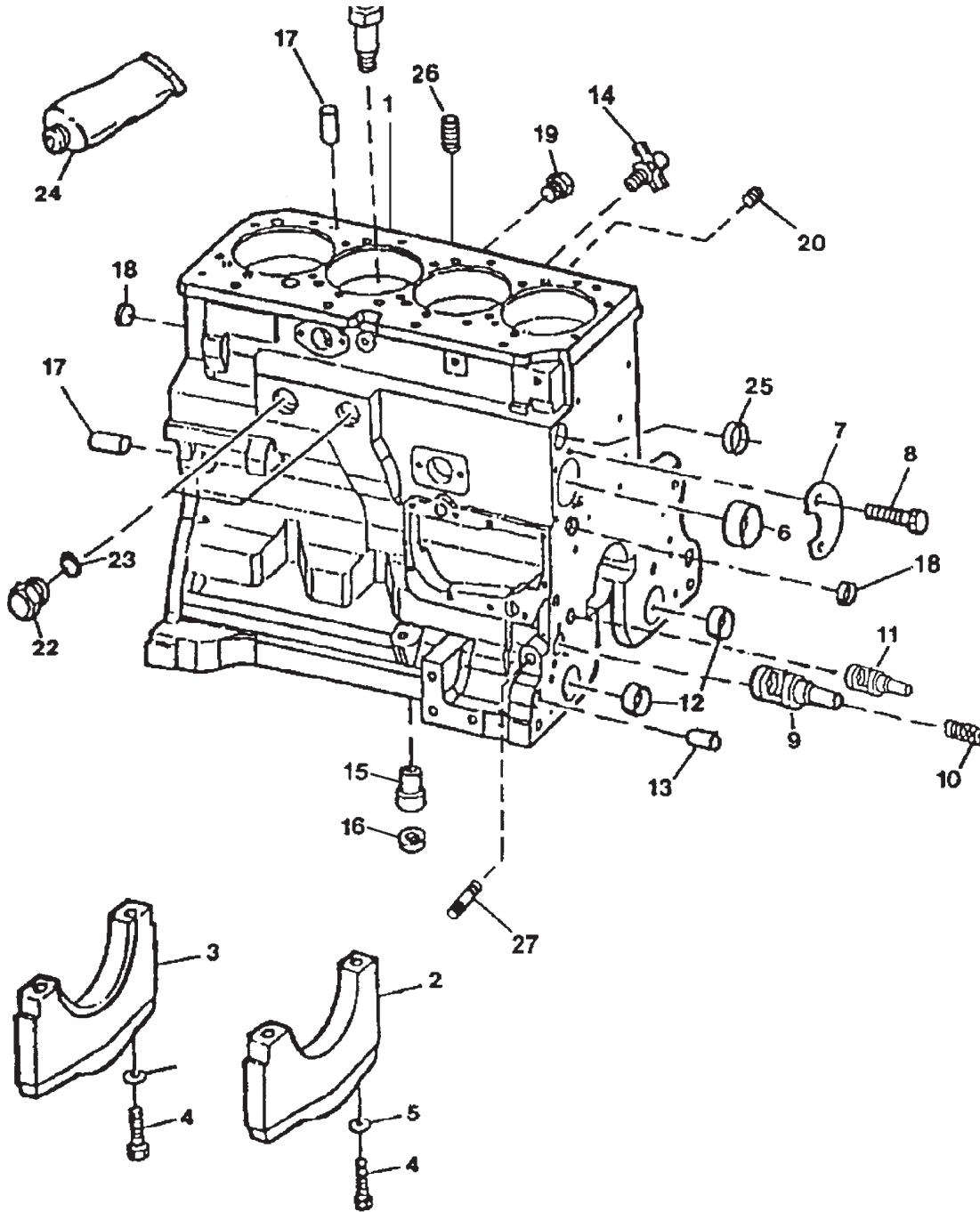

Cylinder Block

L-M-NL1064D, M-NL1064T1-T2, L-M1064A, NL1064H1, M40C2, M55C2, & M65C2

KEY	PART NUMBER	QTY	DESCRIPTION	SERIAL NUMBER
1			Cylinder Block (marked R115081)*	-
2	R114241	4	Bearing Cap	-
3	R132186	1	Bearing Cap	-
4	T23474	10	Capscrew	-
5	T20168	10	Washer	-
6	R119874	1	Bushing	-
7	R132518	1	Plate	-
8	19M8999	2	Screw, M8 x 25	-
9	R121043	1	Oil By-pass Valve	-
10	R111137	1	Spring	-
11	RE505501	1	Oil Pressure Regulating Valve	-
12	R115299	6	Bushing, Balancer Shaft	-
13	R26650	2	Dowel Pin	-
14	AT13740	1	Drain Valve	-
15	R115390	1	Receptacle Connector Body	-
16	R75892	1	O-ring	-
17	R48685	2	Dowel Pin	-
18	T18891	2	Plug	-
19	R55233	1	Pipe Plug	-
20	R104592	5	Pipe Plug	-
21	R131182	4	Orifice	-
22	RE508185	2	Plug	-
23	U13639	2	O-ring	-
24	T43514	1	Gasket	-
25	R116466	1	Plug	-
26	15H624	1	Pipe Plug, 1/2" NPT	-
27	15H623	1	Pipe Plug, 3/8" NPT	-

*Not available separately - see short block listing.

Cylinder Block

M1064H & NL1064H2

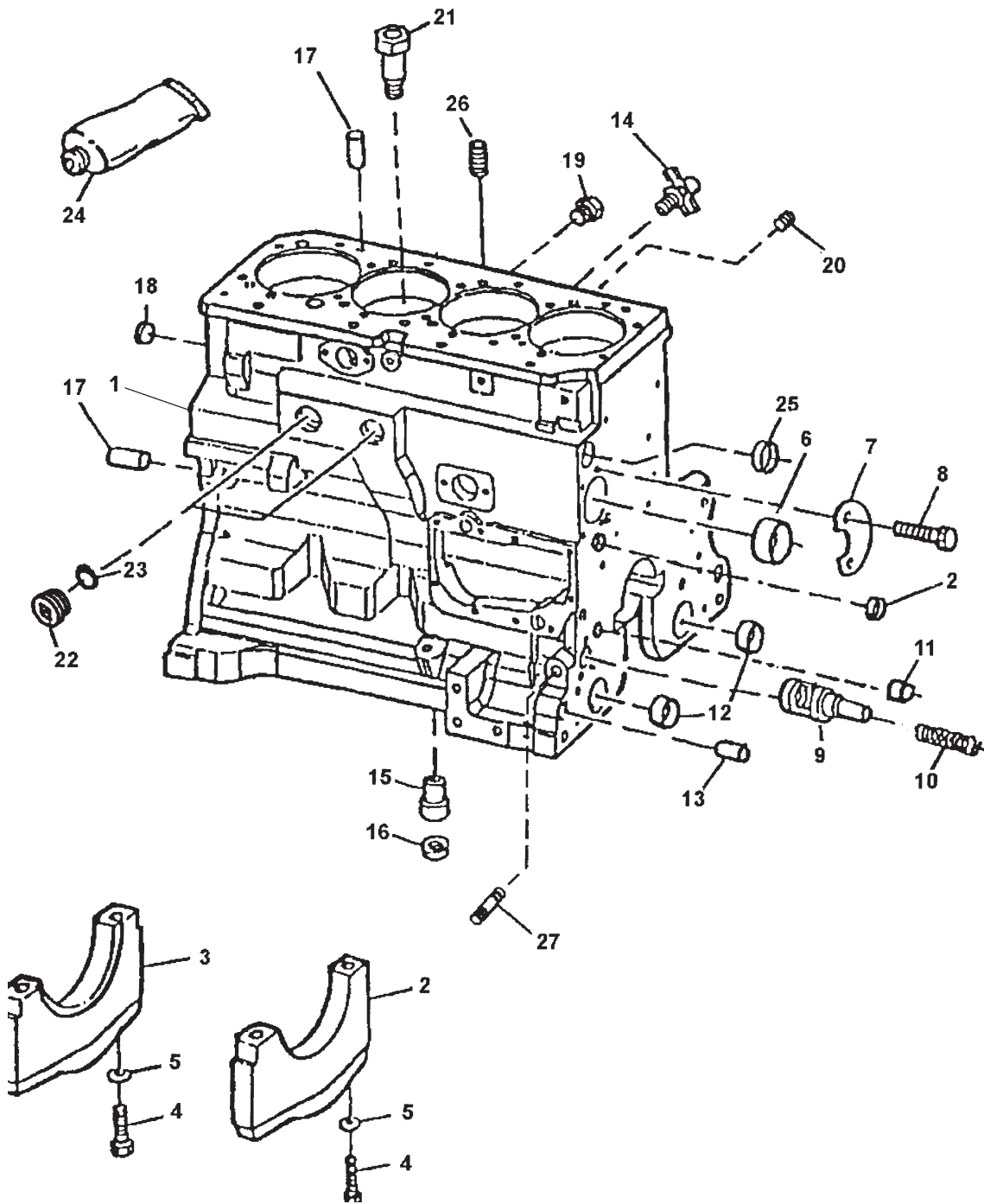

Cylinder Block

M1064H & NL1064H2

KEY	PART NUMBER	QTY	DESCRIPTION	SERIAL NUMBER
1		1	Cylinder Block (marked R504849)	-
2	R114241	4	Bearing Cap	-
3	R132186	1	Bearing Cap	-
4	T23474	10	Capscrew	-
5	T20168	10	Washer	-
6	R119874	1	Bushing	-
7	R132518	1	Plate	-
8	19M7867	2	Screw, M8 x 25	-
9	R121043	1	Valve, Engine Oil By-pass	-
10	R111137	1	Spring	-
11	RE505501	1	Oil Pressure Regulating Valve	-
12	R115299	6	Bushing, Balancer Shaft	-
13	R26650	2	Dowel Pin	-
14	AT13740	1	Drain Valve	-
15	R115390	1	Receptacle Connector Body	-
16	R75892	1	O-ring	-
17	R48685	2	Dowel Pin	-
18	T18891	2	Plug	-
19	R55233	1	Pipe Plug	-
20	R104592	5	Pipe Plug	-
21	R131182	4	Orifice	-
22	RE508185	2	Plug	-
23	U13639	2	O-ring	-
24	T43514	1	Gasket	-
25	R116466	1	Plug	-
26	15H624	1	Pipe Plug, 1/2" NPT	-
27	15H623	1	Pipe Plug, 3/8" NPT	-

Cylinder Block

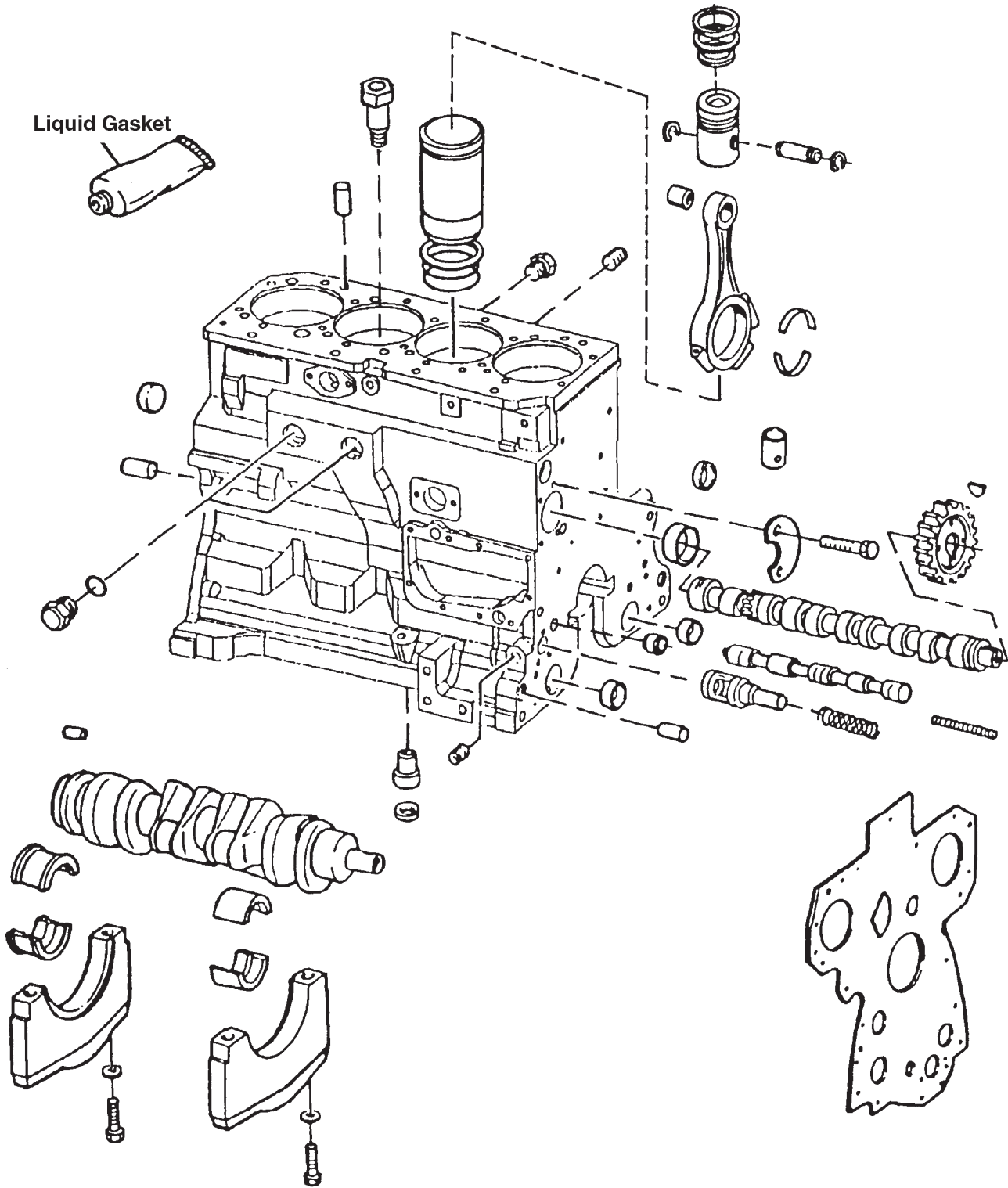

Cylinder Block

KEY	PART NUMBER	QTY	DESCRIPTION	SERIAL NUMBER
• •	RE519593	1	Short Block (for 1064D & M40C2, marked R115081)	
	RE519637	1	Short Block (for 1064T1, T2 & A, & M55C2 marked R115081 for Stanadyne DE10 injection pump without auxiliary drive, furnish RE515670 kit, for Stanadyne DE10 injection pump with auxiliary drive furnish RE515671 kit. Piston marked RE509540 code 4822)	
	RE522679	1	Short Block (for 1064H, marked R504849, Piston marked RE507758)	-
	RE516099	1	Short Block (for 1064T2 & M55C2, marked R115081, Piston marked RE515372 code 4823)	-

GROUP 1 – ENGINE

Flywheel Housing SAE #4

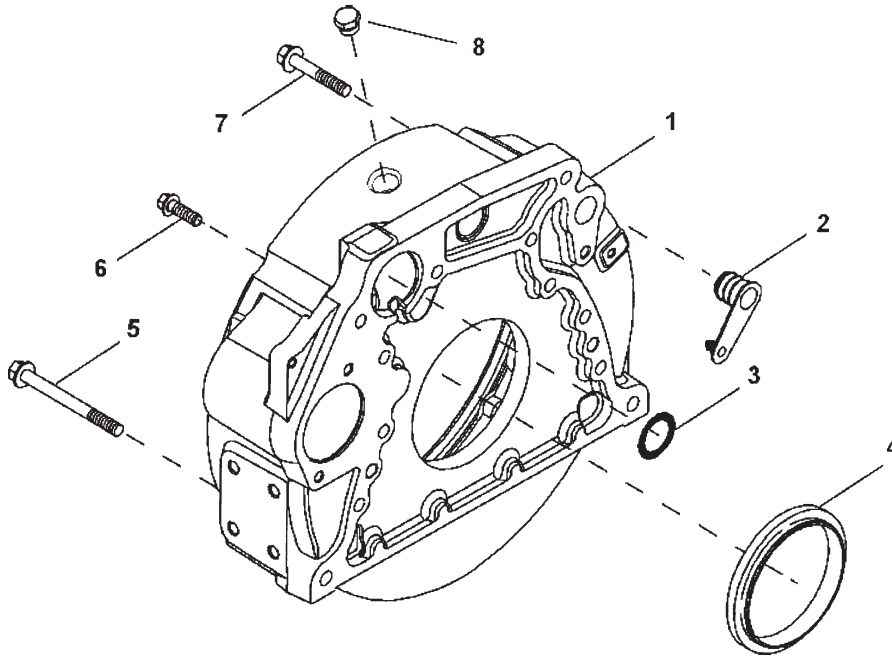

Reproduced by permission of Deere & Co., c2005. Deere & Company. All rights reserved.

RGP7404

KEY	PART NUMBER	QTY	DESCRIPTION	SERIAL NUMBER
1	R503447	1	Housing (also order R61467)	-
2	R131765	1	Plug	-
3	R61467	1	O-ring	-
4	RE44574	1	Seal	-
5	19M7838	2	Screw, M12 x 130	-
6	R135918	8	Bolt	-
7	19M8306	2	Screw, M12 x 50	-
8	R39112	**	Plug	-
			**As required	

Flywheel Housing SAE #3

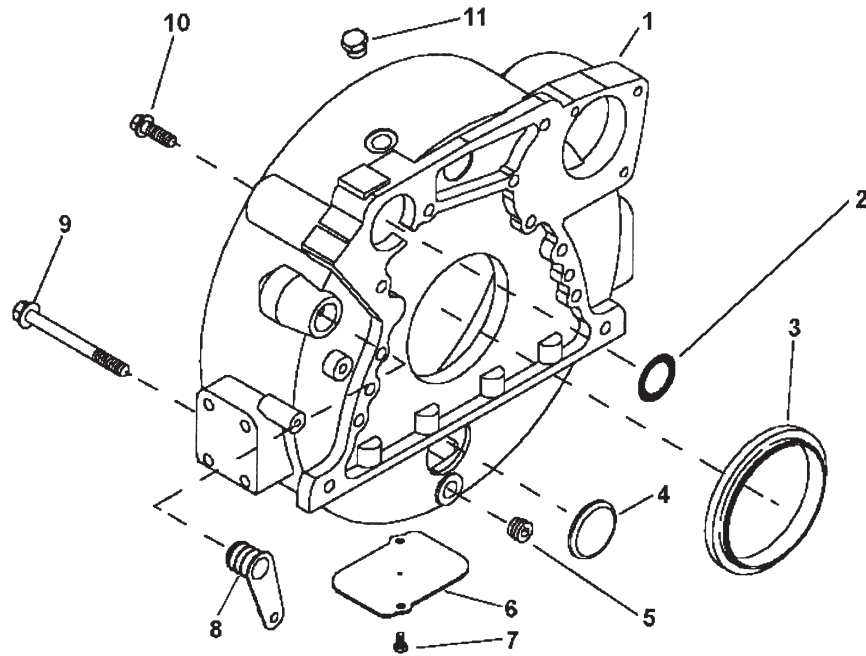

Reproduced by permission of Deere & Co., c2005. Deere & Company. All rights reserved.

RGP7501

KEY	PART NUMBER	QTY	DESCRIPTION	SERIAL NUMBER
1	R503451	1	Housing	-
2	R61467	1	O-ring	-
3	RE44574	1	Seal	-
4	T13518	1	Plug	-
5	15H624	1	Pipe Plug, 12.7 mm	-
6	R121039	1	Plate	-
7	19M7923	2	Capscrew, M6 x 12	-
8	R131769	1	Plug	-
9	19M8306	4	Screw, M12 x 50	-
10	R135918	8	Bolt	-
11	R39112	**	Plug	-
			**As required	

Flywheel Housing SAE #3 Special

Units with Dual Starting Systems

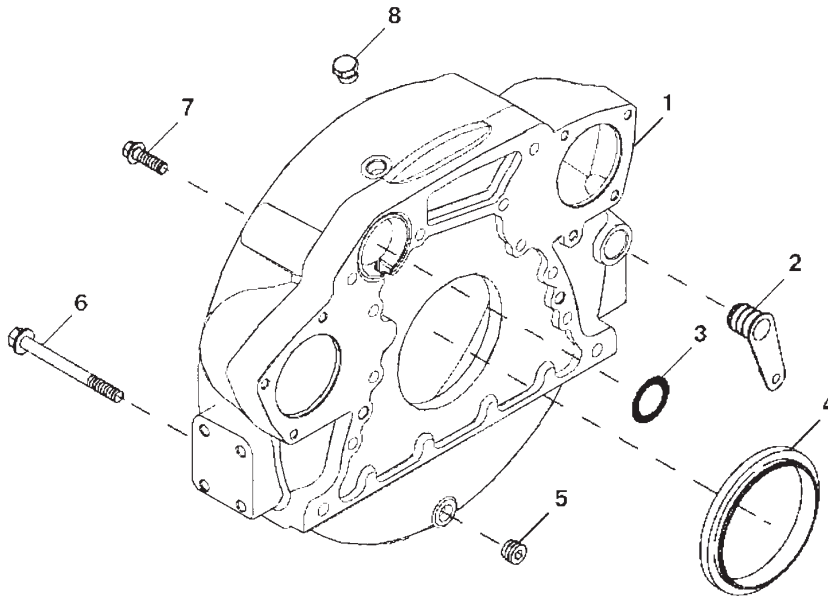

Reproduced by permission of Deere & Co., c2007. Deere & Company. All rights reserved.

RGP7315

KEY	PART NUMBER	QTY	DESCRIPTION	SERIAL NUMBER
1	R500329	1	Flywheel Housing	-
2	R131769	1	Plug	-
3	R61467	1	O-ring	-
4	RE44574	1	Seal	-
5	15H624	1	Pipe Plug	-
6	19M8306	4	Screw, M12 x 50	-
7	R135918	8	Bolt	-
8	R39112	**	Plug	-
			**As required	

Flywheel SAE #10

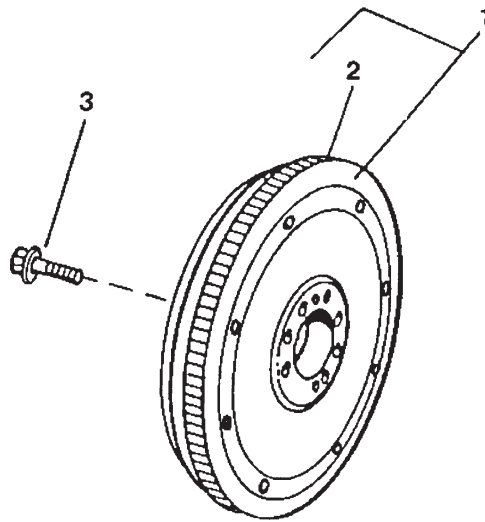

Reproduced by permission of Deere & Co., c2005. Deere & Company. All rights reserved.

TP49563

KEY	PART NUMBER	QTY	DESCRIPTION	SERIAL NUMBER
1	RE58574	1	Flywheel (marked R122409, includes key #2)	-
2	R114282	1	Ring Gear (142 Teeth)	-
3	R135918	4	Bolt	-

Flywheel SAE #11-1/2

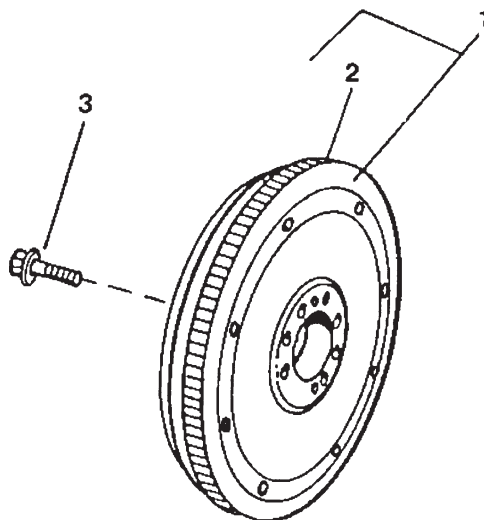

Reproduced by permission of Deere & Co., c2005. Deere & Company. All rights reserved.

TP49563

KEY	PART NUMBER	QTY	DESCRIPTION	SERIAL NUMBER
1	RE500398	1	Flywheel (marked R500219, includes key #2)	-
	RE506389	1	Flywheel (special for Dual Starting Systems)	-
2	R28811	1	Ring Gear (129 teeth)	-
3	R135918	4	Bolt	-

Crankshaft and Main Bearings

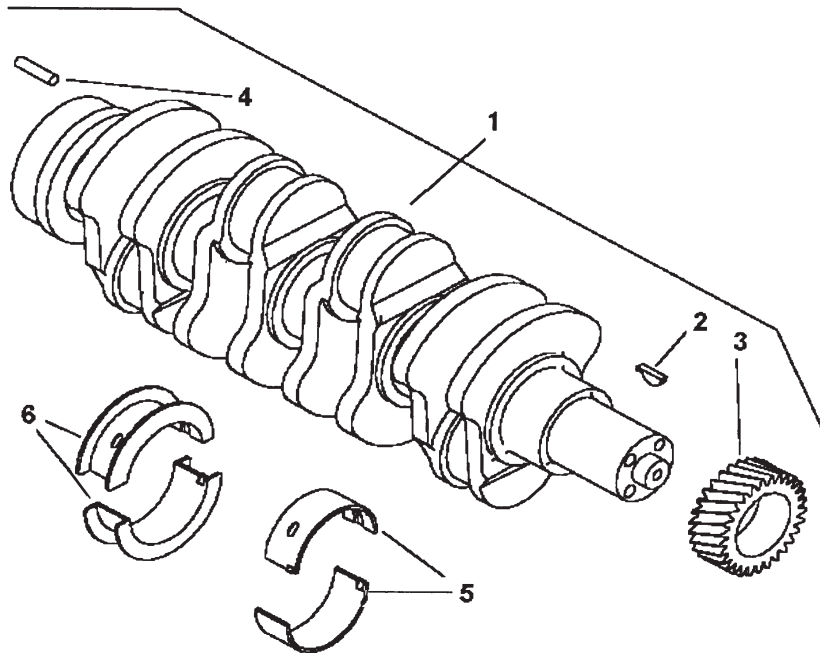

Reproduced by permission of Deere & Co., c2006. Deere & Company. All rights reserved.

RGP8812

KEY	PART NUMBER	QTY	DESCRIPTION	SERIAL NUMBER
1	RE506195	1	Crankshaft (marked R503715, includes keys 2-4)	-
2	26M4224	1	Shaft Key	-
	R505609	1	Shaft Key (1064D & T1)	-
3	R120631	1	Gear (30 teeth)	-
4	R48685	1	Dowel Pin	-
5	RE65165	4	Main Bearing Kit (Standard)	-
	RE65911	4	Main Bearing Kit (undersize .254 mm)	-
6	RE65168	1	Thrust Bearing Kit (Standard)	-
	RE65912	1	Thrust Bearing (undersize .254 mm)	-

Crankshaft Pulley, Marine Applications

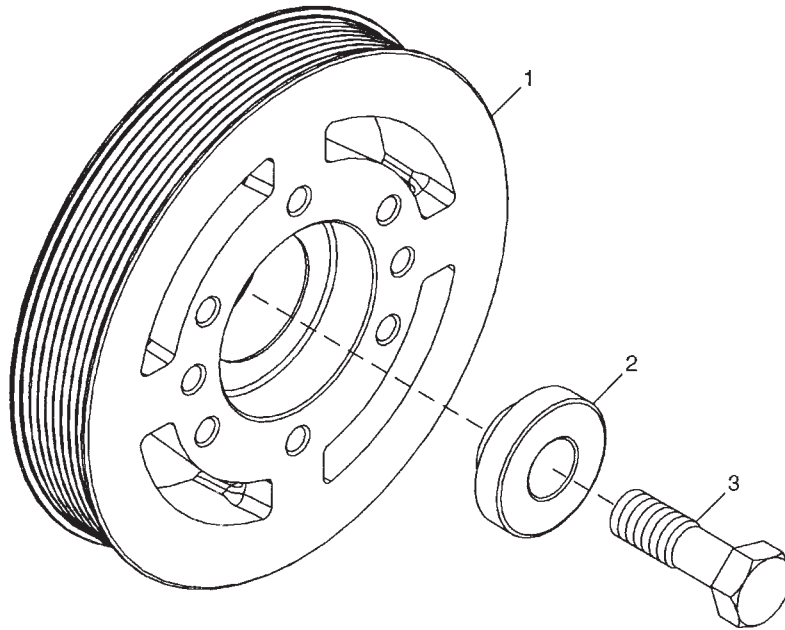

Reproduced by permission of Deere & Co., c2006. Deere & Company. All rights reserved.

RGP9631

KEY	PART NUMBER	QTY	DESCRIPTION	SERIAL NUMBER
1	R517208	1	Pulley (168 mm O.D.)*	-
	R517207	1	Pulley (188 mm O.D.)**	-
2	R517237	1	Washer	-
3	R516648	1	Capscrew, Hex Head M20 x 2.5 x 70 mm Grade 12.9	-
			*for L-M1064D	
			**for M1064T1-T2, L-M1064A, and M1064H	

Crankshaft Pulley, Industrial Application

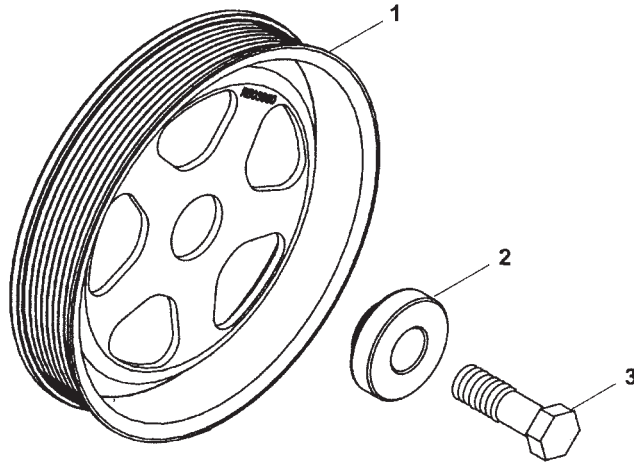

Reproduced by permission of Deere & Co., c2005. Deere & Company. All rights reserved.

RGP8412

KEY	PART NUMBER	QTY	DESCRIPTION	SERIAL NUMBER
1	R505567	1	Pulley (168 mm O.D.)*	-
	R503880	1	Pulley (188 mm O.D.)**	-
2	R515040	1	Washer	-
3	4258061	1	Bolt	-
			*for NL1064D -T1- T2 - H1	
			**for NL1064H2	

Crankshaft Pulley

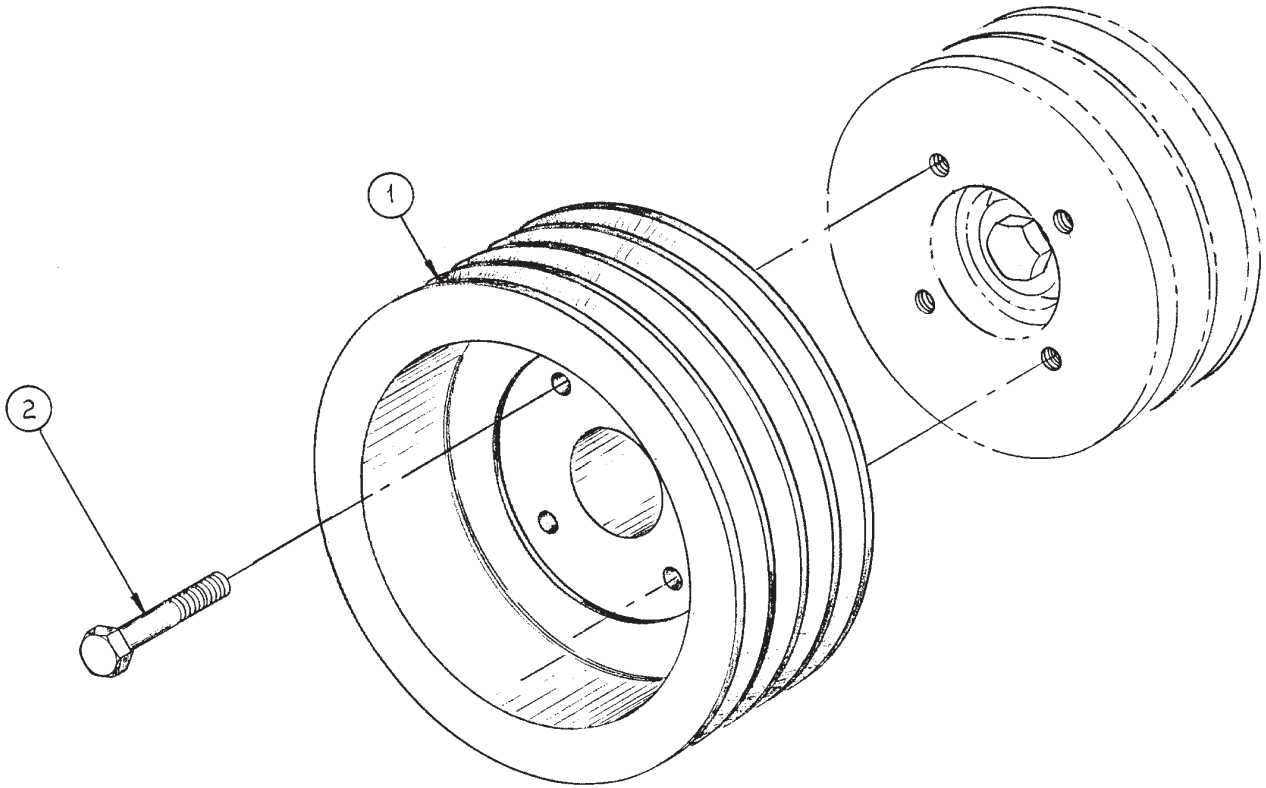

Reproduced by permission of Deere & Co., c2005. Deere & Company. All rights reserved.

A-10446 & A-10447/ B-3732

KEY	PART NUMBER	QTY	DESCRIPTION	SERIAL NUMBER
1	34-69502	1	Pulley, Crankshaft 3-A/B x 8"	-
	34-69501	1	Pulley, Crankshaft 4-A x 8"	-
2	01435-01065	4	Capscrew, Hex Head Flanged M10 x 1.5 x 65 mm	-

Cylinder Liner Assembly and Connecting Rod

L-M-NL1064D, & M40C2

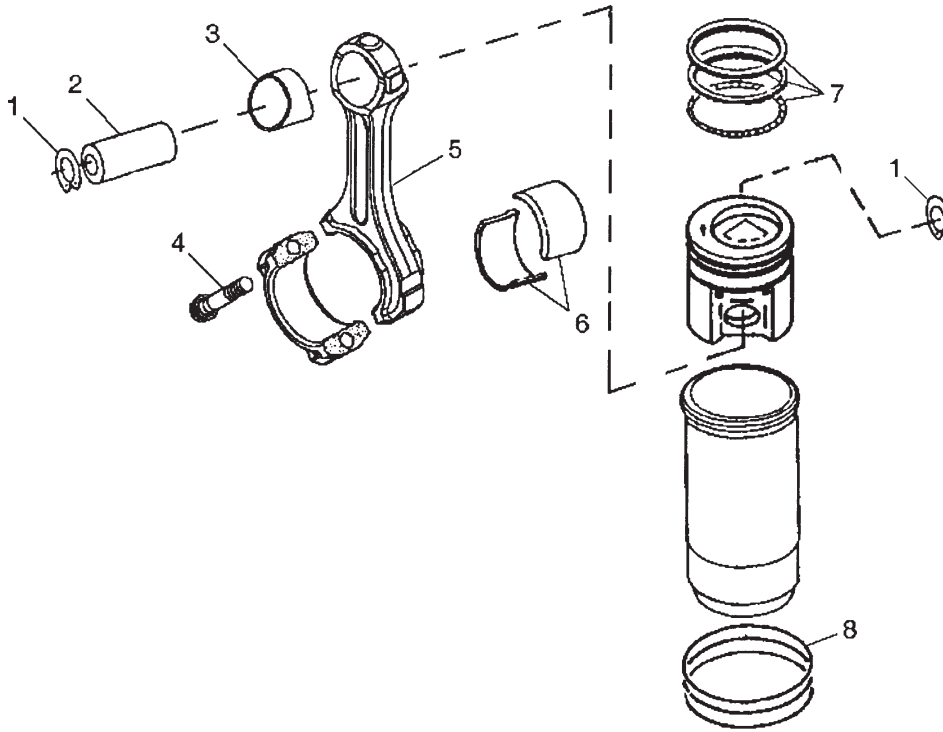

Reproduced by permission of Deere & Co., c2005. Deere & Company. All rights reserved.

RGP6650

KEY	PART NUMBER	QTY	DESCRIPTION	SERIAL NUMBER
••	RE520835	4	Piston Liner Kit (marked RE505101)	-
1	M41029	8	Snap Ring	-
2	R123178	4	Piston Pin	-
3	R123960	4	Bushing	-
4	R501124	8	Screw	-
5	RE500002	4	Connecting Rod (marked R500000)	-
6	RE65908	4	Bearing (Standard)	-
	RE65909	4	Bearing (undersize .010")	-
7	RE66271	4	Piston Ring Kit	-
8	AR65507	4	O-ring Kit	-
	R26121	4	O-ring	-
	R48767	4	Packing	-
	R55453	4	O-ring	-

Cylinder Liner Assembly and Connecting Rod

M-NL1064T1, & M55C2

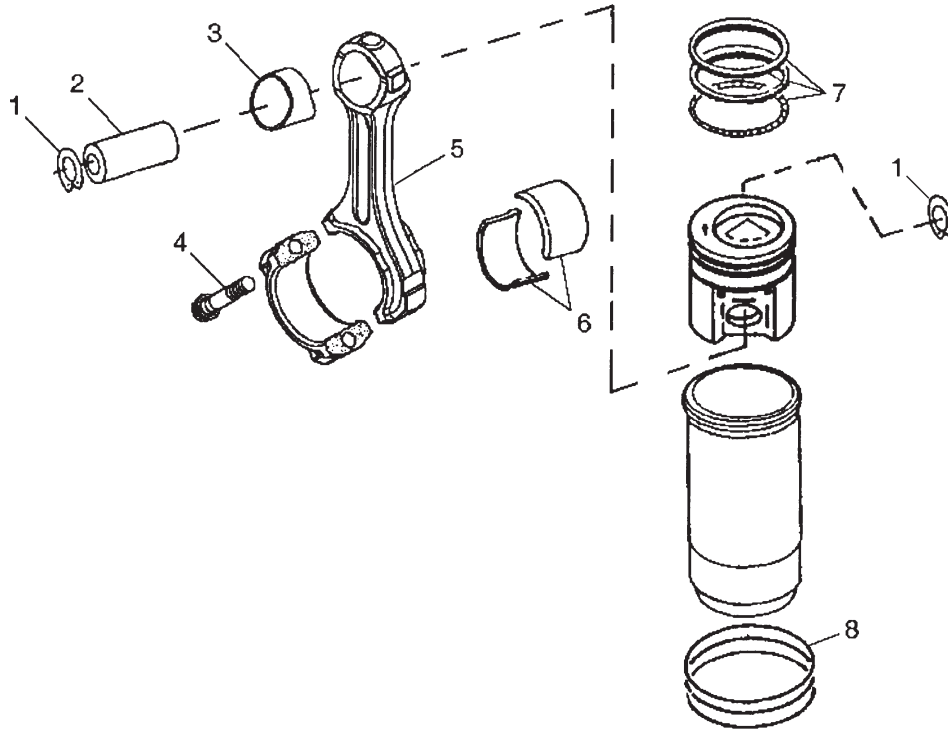

Reproduced by permission of Deere & Co., c2005. Deere & Company. All rights reserved.

RGP6650

KEY	PART NUMBER	QTY	DESCRIPTION	SERIAL NUMBER
••	RE507920	4	Piston Liner Kit (marked RE515372, includes keys #7-8)	-
1	M41029	8	Snap Ring	-
2	R123178	4	Piston Pin	-
3	R123960	4	Bushing	-
4	R501124	8	Screw	-
5	RE500002	4	Connecting Rod (marked R500000, includes keys #3-4)	-
6	RE65908	4	Bearing (Standard)	-
	RE65909	4	Bearing (undersize .254 mm)	-
7	RE507852	4	Piston Ring Kit	-
8	AR65507	4	O-ring Kit	-

GROUP 1 – ENGINE

Cylinder Liner Assembly and Connecting Rod

M-NL1064T2, L-M1064A, NL1064H1, & M65C2

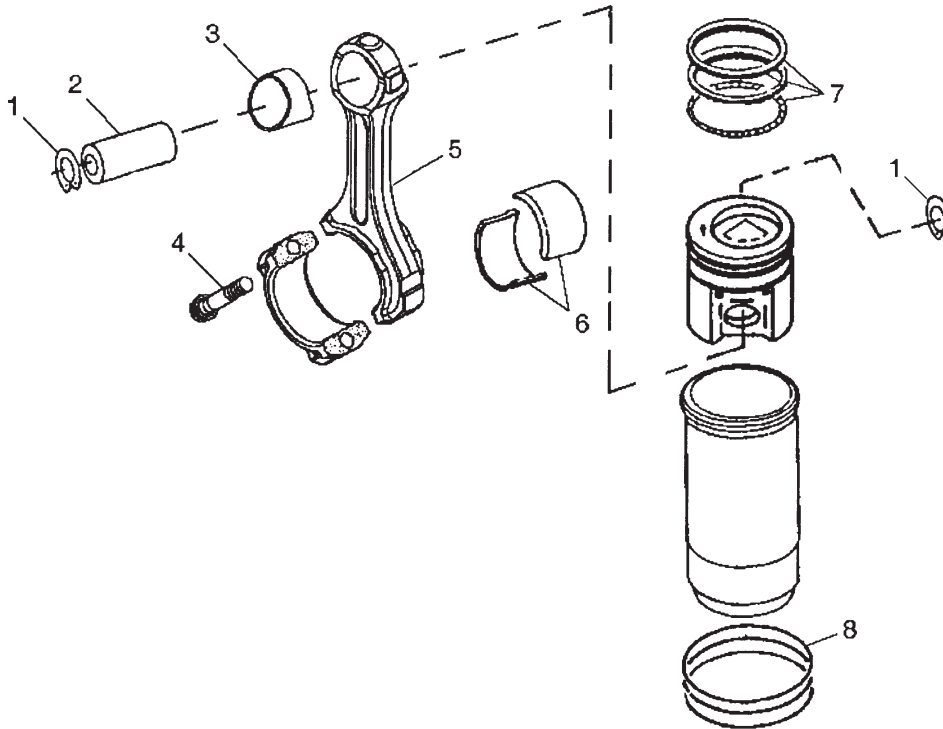

Reproduced by permission of Deere & Co., c2005. Deere & Company. All rights reserved.

RGP6650

KEY	PART NUMBER	QTY	DESCRIPTION	SERIAL NUMBER
••	RE507850	4	Piston Liner Kit (marked RE509540, includes keys #7-8)	-
1	M41029	8	Snap Ring	-
2	R123177	4	Piston Pin	-
3	R114082	4	Bushing	-
4	R501124	8	Screw	-
5	RE500608	4	Connecting Rod (marked R500335, includes keys #3-4)	-
6	RE65908	4	Bearing (Standard)	-
	RE65909	4	Bearing (undersize .254 mm)	-
7	RE507852	4	Piston Ring Kit	-
8	AR65507	4	O-ring Kit	-

Cylinder Liner Assembly and Connecting Rod

M1064H & NL1064H2

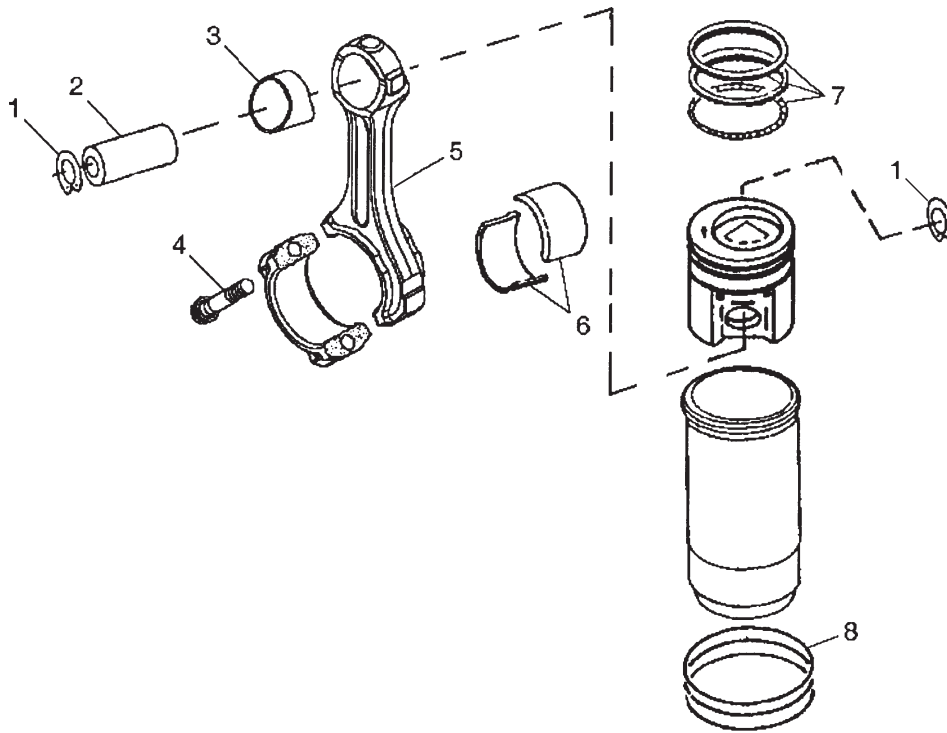

Reproduced by permission of Deere & Co., c2005. Deere & Company. All rights reserved.

RGP6650

KEY	PART NUMBER	QTY	DESCRIPTION	SERIAL NUMBER
••	RE516228	4	Piston Liner Kit (marked RE507758, includes keys #7-8)	-
1	R54114	8	Snap Ring	-
2	R502755	4	Piston Pin	-
3	R114082	4	Bushing	-
4	R501124	8	Screw	-
5	RE500608	4	Connecting Rod (marked R500335, includes keys #3-4)	-
6	RE65908	4	Bearing (Standard)	-
	RE65909	4	Bearing (undersize .254 mm)	-
7	RE516268	4	Piston Ring Kit	-
8	AR65507	4	O-ring Kit	-

Timing Gear Front Plate

L- M1064D, M1064T1 & T2, L- M1064A, M40C2, M55C2, & M65C2

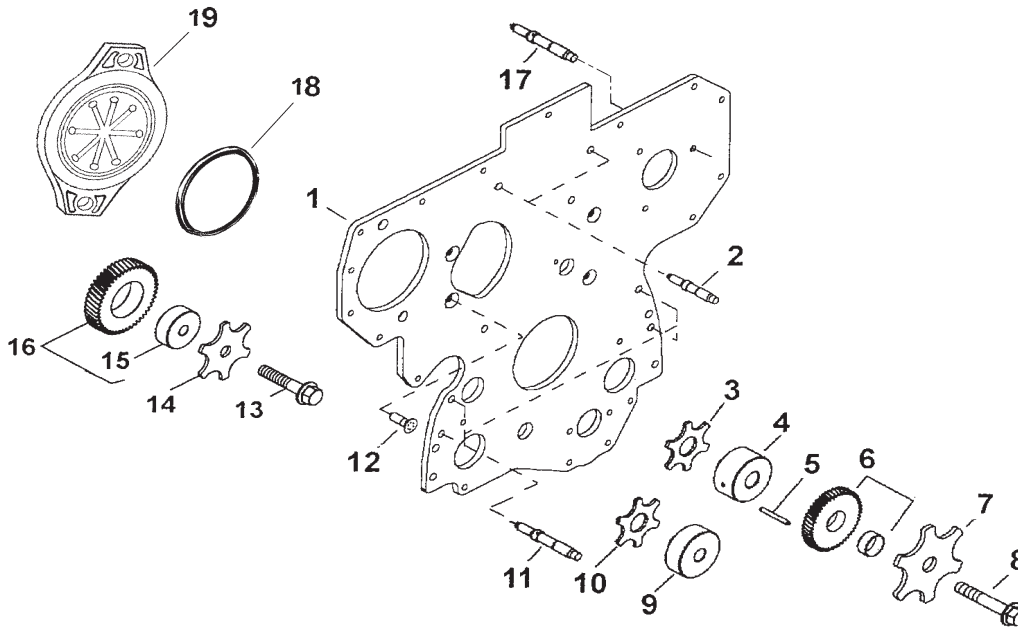

Reproduced by permission of Deere & Co., c2006. Deere & Company. All rights reserved.

RGP8974

KEY	PART NUMBER	QTY	DESCRIPTION	SERIAL NUMBER
1	R134526	1	Plate	-
2	R134518	3	Stud	-
3	R123174	1	Lock Washer	-
4	R120641	1	Shaft, Upper (use with key #5)	-
5	34H288	1	Spring Pin	-
6	RE56313	1	Gear, Upper Idler (marked R120635, includes R130912)	-
7	R131206	1	Thrust Washer, M10 x 65	-
8	19M8997	1	Screw	-
9	R114194	1	Shaft, Lower	-
10	R101225	1	Thrust Washer	-
11	R123584	4	Stud	-
12	R136475	6	Screw	-
13	19M8966	1	Screw, M10 x 50	-
14	R131283	1	Thrust Washer	-
15	R114193	1	Bushing	-
16	RE56369	1	Gear	-
17	R116386	1	Stud	-
18	16-19503	**	O-ring (formerly #T20758)	-
19	R135757	**	Cover	-
			**As required	

Timing Gear Front Plate

M1064H

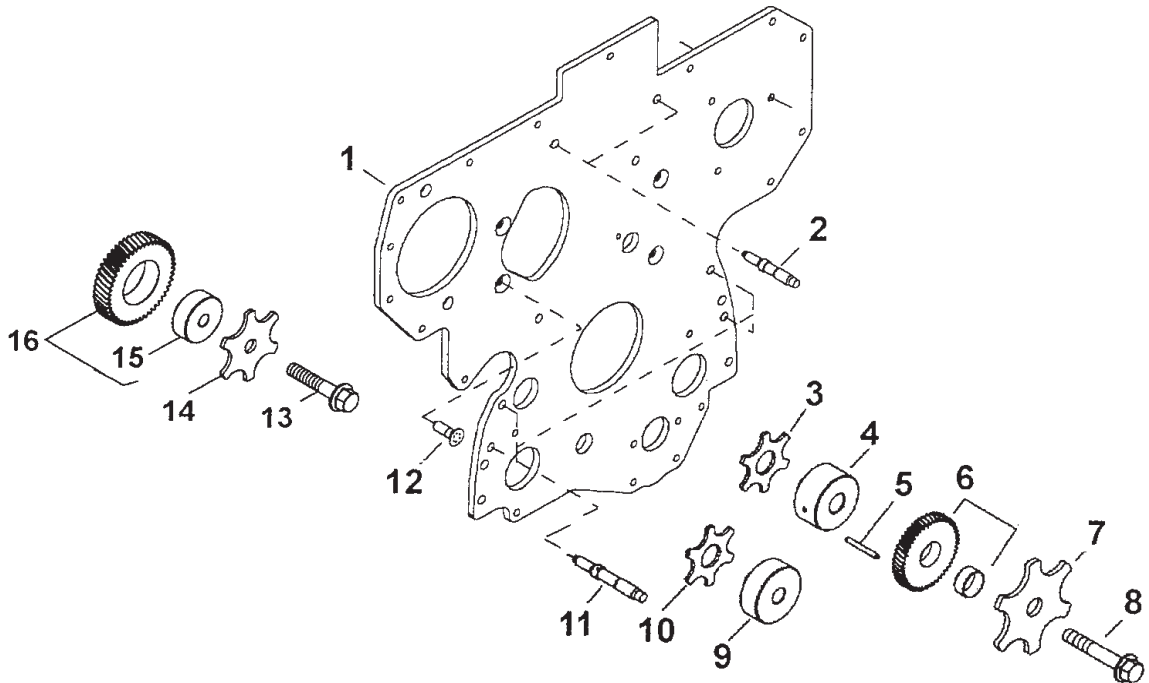

Reproduced by permission of Deere & Co., c2005. Deere & Company. All rights reserved.

RGP8974

KEY	PART NUMBER	QTY	DESCRIPTION	SERIAL NUMBER
1	R504282	1	Plate	-
2	R134518	2	Stud	-
3	R515494	1	Lock Washer	-
4	R504843	1	Shaft, Upper	-
5	R515408	1	Dowel Pin	-
6	RE508489	1	Gear (marked R504614)	-
7	R515494	1	Lock Washer	-
8	19M7807	1	Capscrew, M10 x 60 mm	-
9	R114194	1	Shaft, Lower	-
10	R101225	1	Thrust Washer	-
11	R123584	7	Stud	-
12	R136475	5	Screw	-
13	19M8966	1	Capscrew, M10 x 50 mm	-
14	R131283	1	Thrust Washer	-
15	R114193	1	Bushing	-
16	RE56369	1	Gear	-

Timing Gear Front Plate

NL1064D, T1, T2, & H1

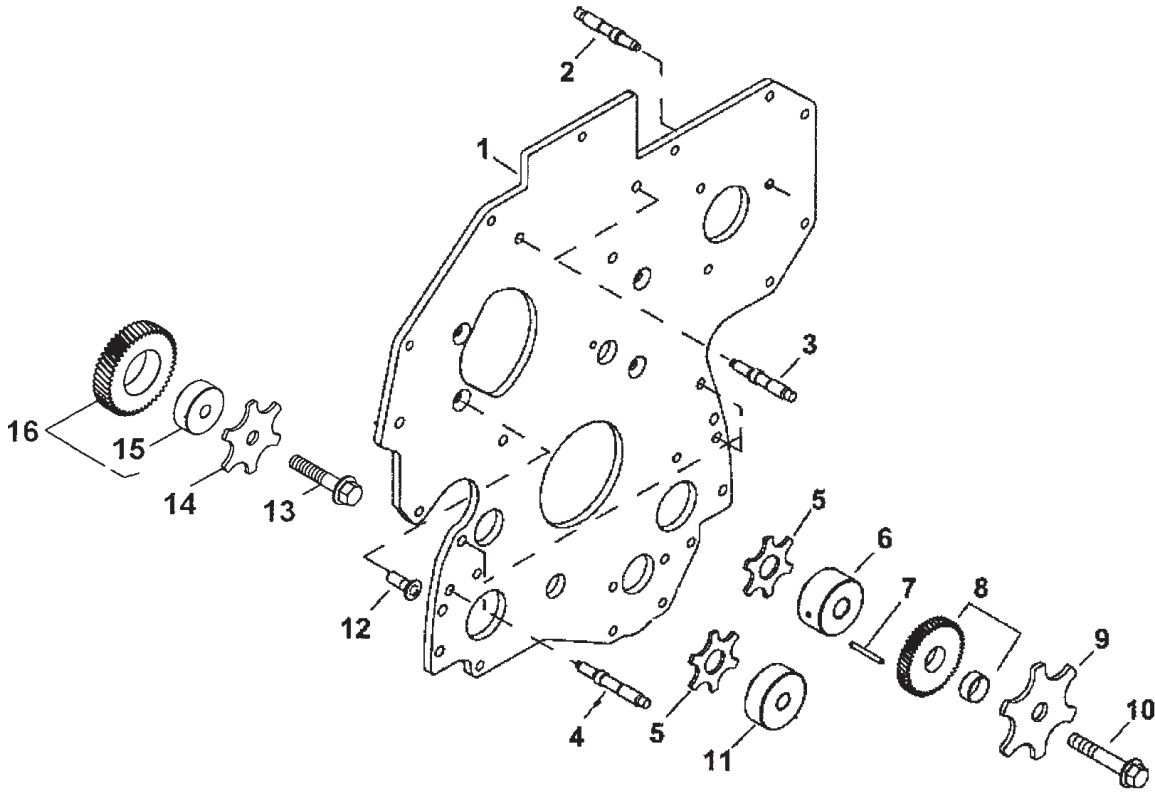

Reproduced by permission of Deere & Co., c2005. Deere & Company. All rights reserved.

RGP8269

KEY	PART NUMBER	QTY	DESCRIPTION	SERIAL NUMBER
1	R134527	1	Plate	-
2	R116386	3	Stud	-
3	R134518	2	Stud	-
4	R123584	4	Stud	-
5	R101225	2	Thrust Washer	-
6	R120641	1	Shaft, Upper	-
7	34H288	1	Spring Pin	-
8	RE56313	1	Gear (marked R120635)	-
9	R131206	1	Thrust Washer, Upper Idler	-
10	19M8997	1	Screw	-
11	R114194	1	Shaft, Lower	-
12	R136475	6	Screw	-
13	19M8966	1	Capscrew, M10 x 50 mm	-
14	R131283	1	Thrust Washer	-
15	R114193	1	Bushing	-
16	RE56369	1	Gear	-

Timing Gear Front Plate

NL1064H2

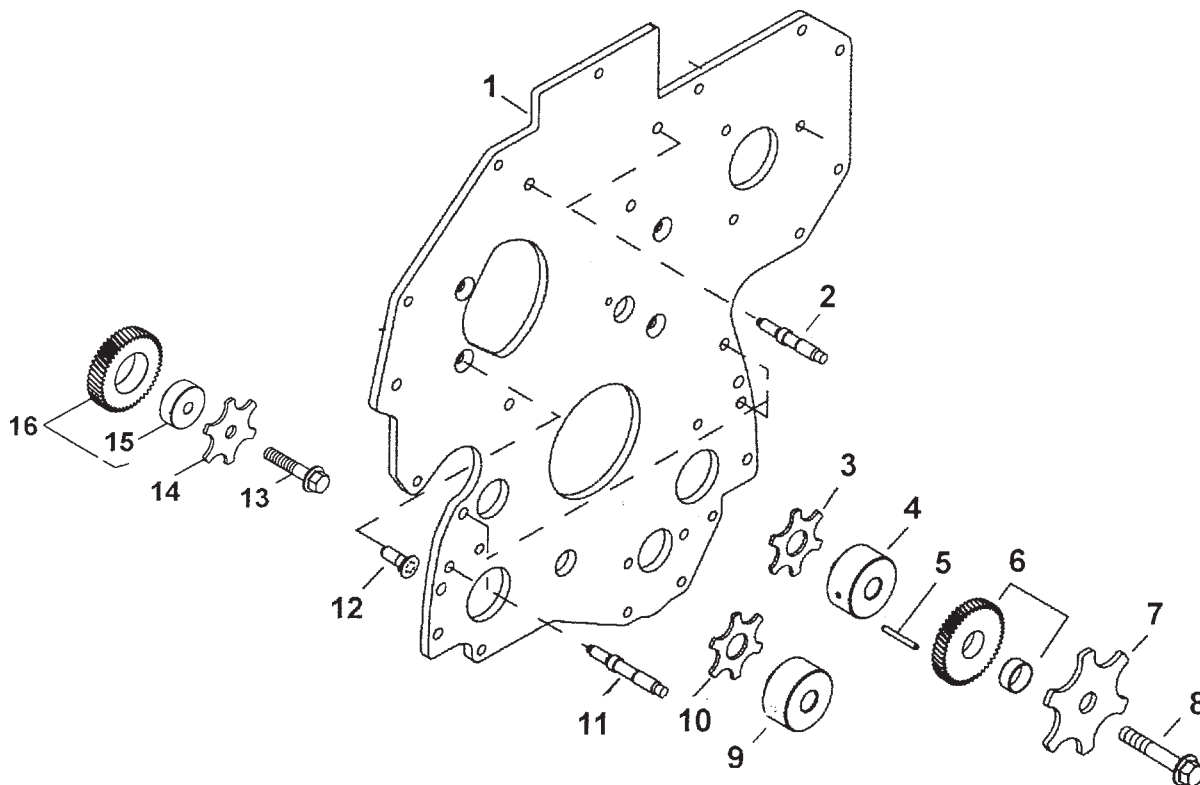

Reproduced by permission of Deere & Co., c2005. Deere & Company. All rights reserved.

RGP8962

KEY	PART NUMBER	QTY	DESCRIPTION	SERIAL NUMBER
1	R504576	1	Plate	-
2	R134518	2	Stud	-
3	R515494	1	Lock Washer	-
4	R504843	1	Shaft,Upper	-
5	R515408	1	Dowel Pin	-
6	RE508489	1	Gear (marked R504614)	-
7	R515494	1	Lock Washer	-
8	19M7807	1	Capscrew, M10 x 60 mm	-
9	R114194	1	Shaft, Lower	-
10	R101225	1	Thrust Washer	-
11	R123584	7	Stud	-
12	R136475	5	Screw	-
13	19M8966	1	Capscrew, M10 x 50 mm	-
14	R131283	1	Thrust Washer	-
15	R114193	1	Bushing	-
16	RE56369	1	Gear	-

Camshaft

L-M-NL1064D, M-NL1064T1-T2, L-M1064A, NL1064H1, M40C2, M55C2, & M65C2

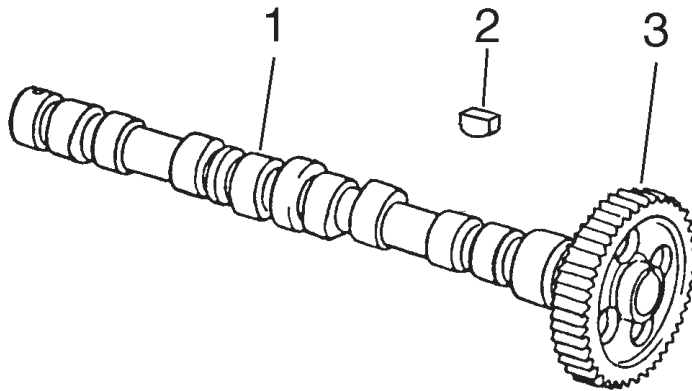

Reproduced by permission of Deere & Co., c2005. Deere & Company. All rights reserved.

TP60711

KEY	PART NUMBER	QTY	DESCRIPTION	SERIAL NUMBER
1	RE507595	1	Camshaft (marked R504534, includes keys #2-3)	-
2	R133303	1	Shaft Key	-
3		1	Gear (60 Teeth, marked R133812)*	-
			*Not available separately - order camshaft assembly	

Camshaft

M1064H & NL1064H2

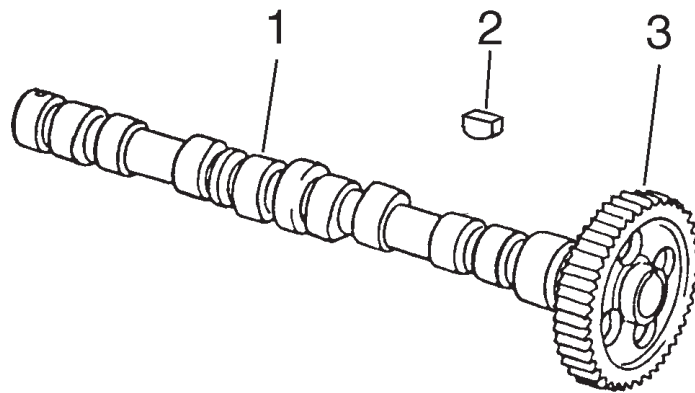

Reproduced by permission of Deere & Co., c2005. Deere & Company. All rights reserved.

TP60711

KEY	PART NUMBER	QTY	DESCRIPTION	SERIAL NUMBER
1	RE515612	1	Camshaft (marked R515247, includes keys #2-3)	-
2	R133303	1	Shaft Key	-
3		1	Gear (60 Teeth, marked R516237)*	-
			*Not available separately, order camshaft assembly	

Engine Balancer Shaft

L-M-NL1064D, M-NL1064T1, M40C2, & M55C2

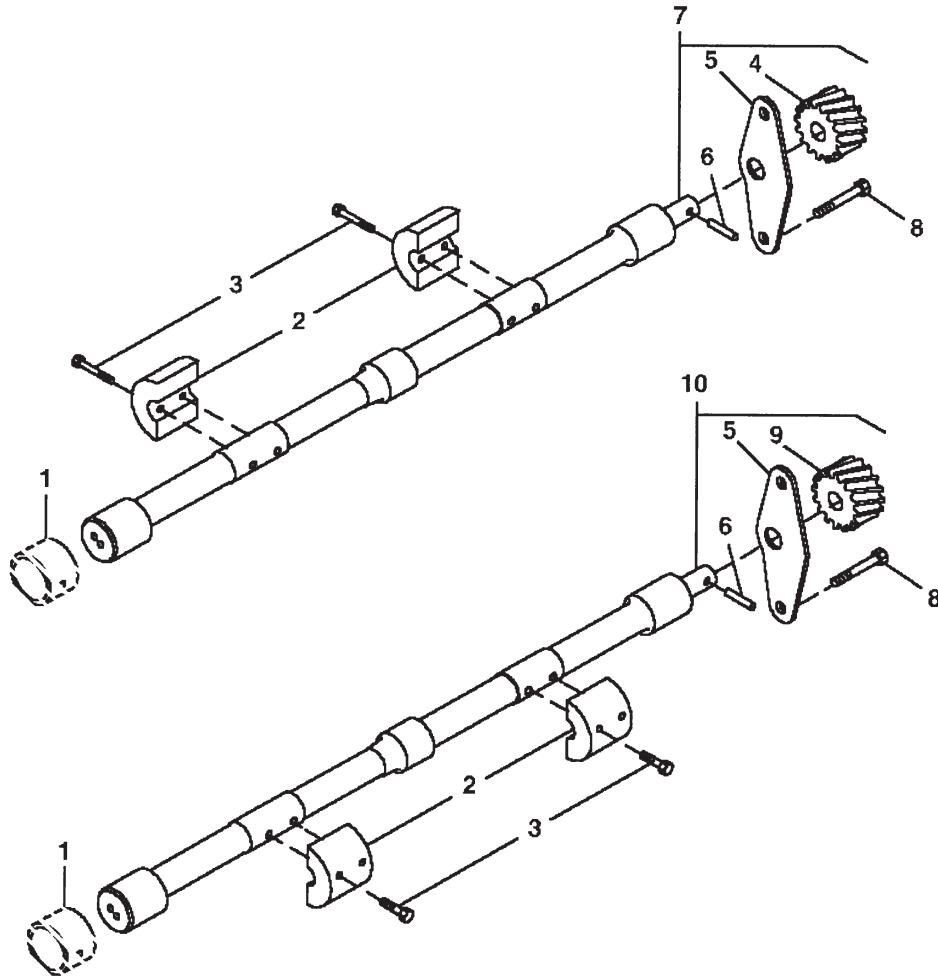

Reproduced by permission of Deere & Co., c2006. Deere & Company. All rights reserved.

RGP5639

KEY	PART NUMBER	QTY	DESCRIPTION	SERIAL NUMBER
1	R115299	6	Bushing	-
2	R500265	4	Weight	-
3	19M7798	8	Capscrew, M8 x 40 mm	-
4	R120639	1	Gear (Left hand Shaft)	-
5	R116078	2	Plate	-
6	R133303	1	Shaft Key	-
7	RE500449	1	Balancer Shaft (Left hand, marked R500266)	-
8	19M7864	4	Capscrew, M8 x 12 mm	-
9	R120637	1	Gear (Right hand)	-
10	RE500448	1	Balancer Shaft (Right hand, marked R500668)	-

Engine Balancer Shaft

M-NL1064T2, L-M1064A, M1064H, NL1064H1-H2, & M65C2

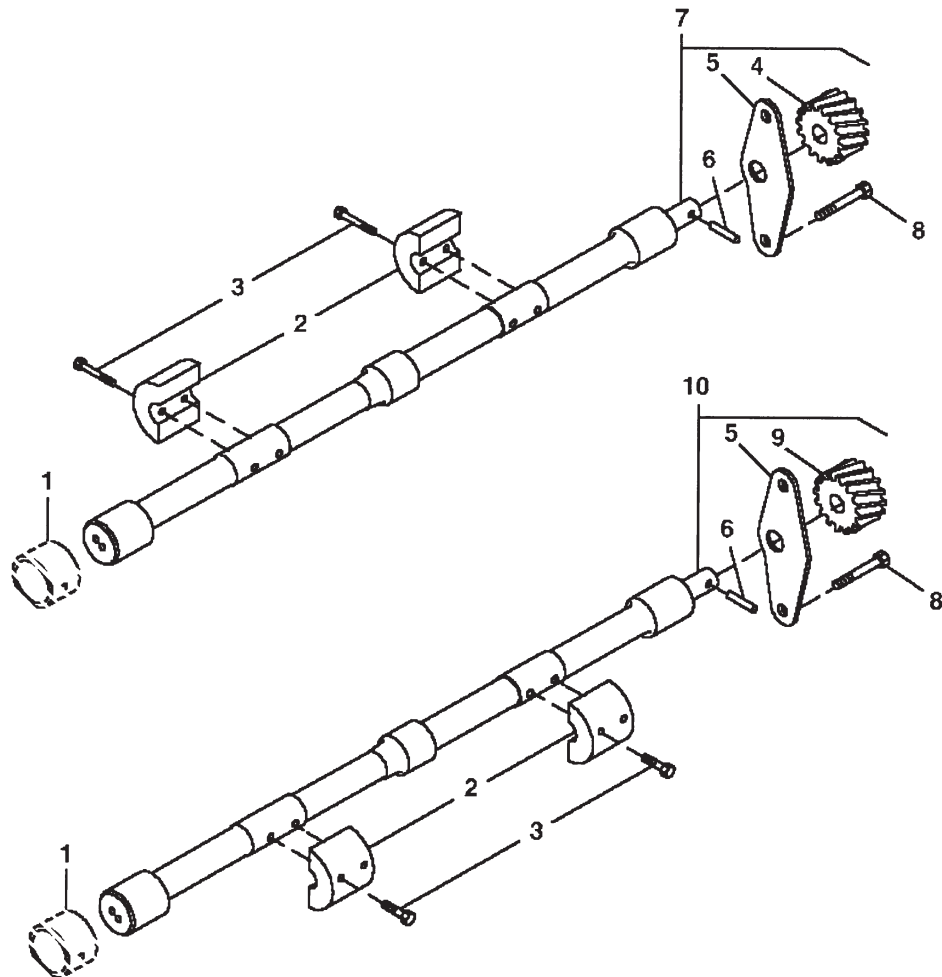

Reproduced by permission of Deere & Co., c2006. Deere & Company. All rights reserved.

RGP5639

KEY	PART NUMBER	QTY	DESCRIPTION	SERIAL NUMBER
1	R115299	6	Bushing	-
2	R500650	4	Weight	-
3	19M8882	8	Capscrew, M8 x 40 mm	-
4	R120639	1	Gear (Left hand shaft, 15 teeth)	-
5	R116078	2	Plate	-
6	34M7089	1	Dowel Pin, 4 x 12 mm	-
7	RE500449	1	Balancer Shaft (marked R500266)	-
8	19M8998	4	Screw, M8 x 12	-
9	R120637	1	Gear (Right hand)	-
10	RE500448	1	Balancer Shaft (marked R500668)	-

Timing Gear Cover

L-M1064D, M1064T1, T2 & A, M40C2, M55C2, & M65C2

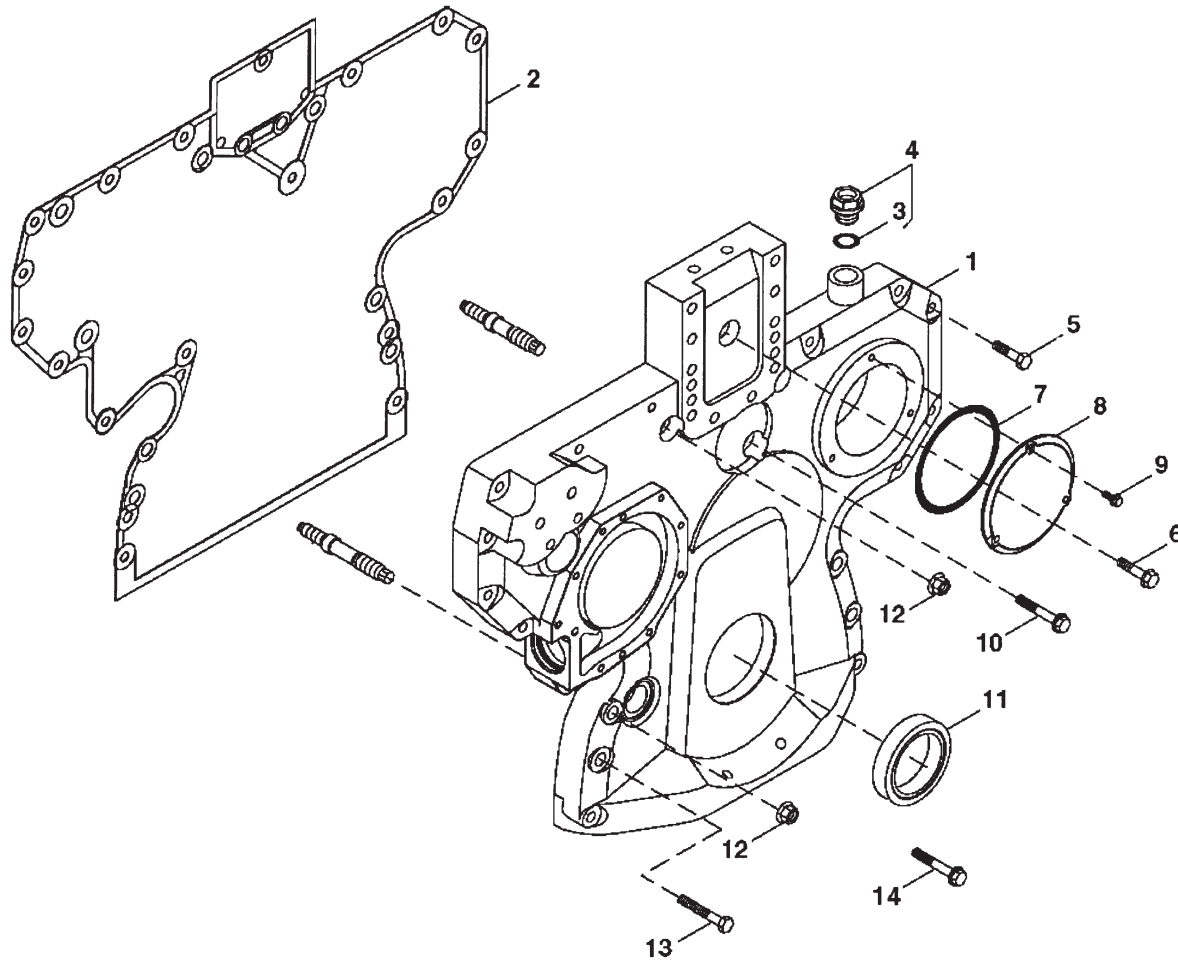

Reproduced by permission of Deere & Co., c2006. Deere & Company. All rights reserved.

RGP8277

KEY	PART NUMBER	QTY	DESCRIPTION	SERIAL NUMBER
1	R504724	1	Cover (Replaced by R520129, also order installation kit RE515978)	-
	R520129	1	Cover	-
2	R136515	1	Gasket (use with cover R504724)	-
	R520131	1	Gasket (use with cover R520129)	-
3	51M7044	1	O-ring	-
4	RE517370	1	Plug M20 x 1.5 (formerly RE501938)	-
5	RE67239	1	Screw	-
6	19M8291	1	Capscrew, M8 x 35 mm	-
7	R121424	1	O-ring	-
8	R121411	1	Cover	-
9	19M7775	3	Capscrew, M6 x 16 mm	-
10	RE67239	2	Capscrew	-
11	RE59810	1	Seal Kit	-
12	14M7296	6	Flange Nut	-
13	19M7979	2	Screw	-
14	19M7801	1	Capscrew, M8 x 60 mm	-

Timing Gear Cover

M1064H

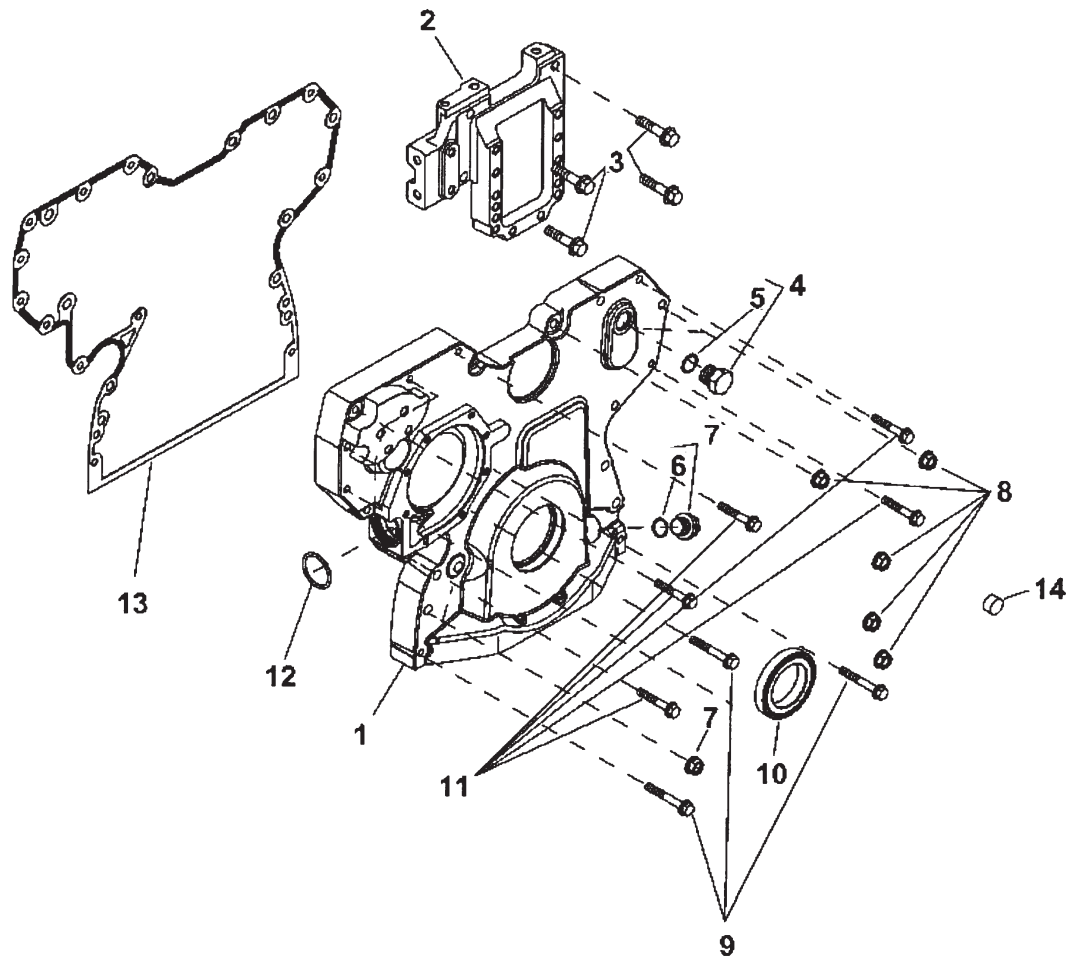

Reproduced by permission of Deere & Co., c2006. Deere & Company. All rights reserved.

RGP9019

KEY	PART NUMBER	QTY	DESCRIPTION	SERIAL NUMBER
1	RE509865	1	Timing Gear Cover (former # RE503596)	-
2	R516557	1	Adapter	-
3	19M7805	4	Capscrew, M10 x 45 mm	-
4	RE46687	1	Drain Plug	-
5	51M7045	1	O-ring	-
6	51M7044	1	O-ring	-
7	RE501938	1	Plug	-
8	14M7296	9	Flange Nut	-
9	19M7801	3	Capscrew, M8 x 60 mm	-
10	RE516340	1	Bearing Kit	-
11	19M7800	5	Screw	-
12	R504734	1	O-ring	-
13	R503597	1	Gasket	-

GROUP 1 – ENGINE

Timing Gear Cover

NL1064D, T1, T2 & H1

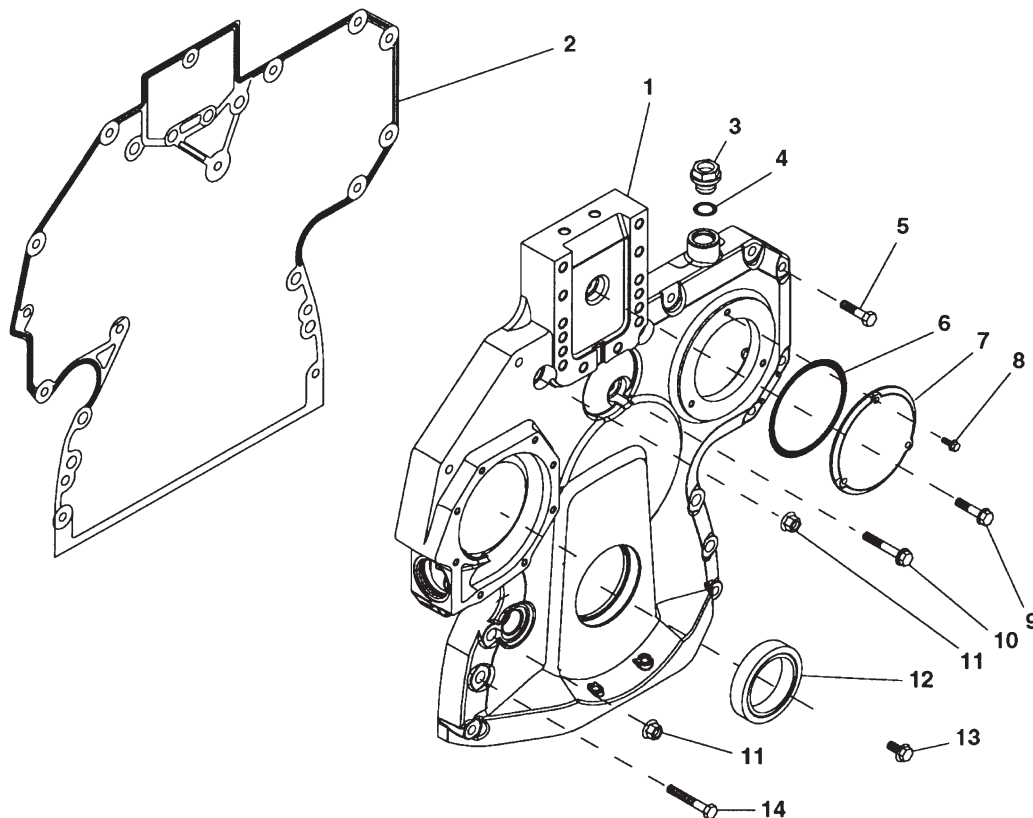

Reproduced by permission of Deere & Co., c2006. Deere & Company. All rights reserved.

RG8338a

KEY	PART NUMBER	QTY	DESCRIPTION	SERIAL NUMBER
1	R504725	1	Cover (replaced by R520130 cover, R520132 gasket & RE515978 Installation kit)	-
	R520130	1	Timing Cover	-
2	R136516	1	Gasket (use with R504725)	-
	R520132	1	Gasket (use with R520130)	-
3	RE517370	1	Fitting Plug (includes key #4)	-
4	51M7044	1	O-ring	-
5	19M8317	1	Capscrew, M8 x 40 mm	-
6	R121424	1	O-ring	-
7	R121411	1	Cover	-
8	19M7775	3	Capscrew, M6 x 16 mm	-
9	19M8291	1	Capscrew, M8 x 35 mm	-
10	RE67239	2	Capscrew, M8 x 45 mm	-
11	14M7296	6	Flange Nut	-
12	RE59810	1	Seal Kit	-
13	19M7801	1	Capscrew, M8 x 60 mm	-
14	19M7979	2	Capscrew, M8 x 55 mm	-

Timing Gear Cover

NL1064H

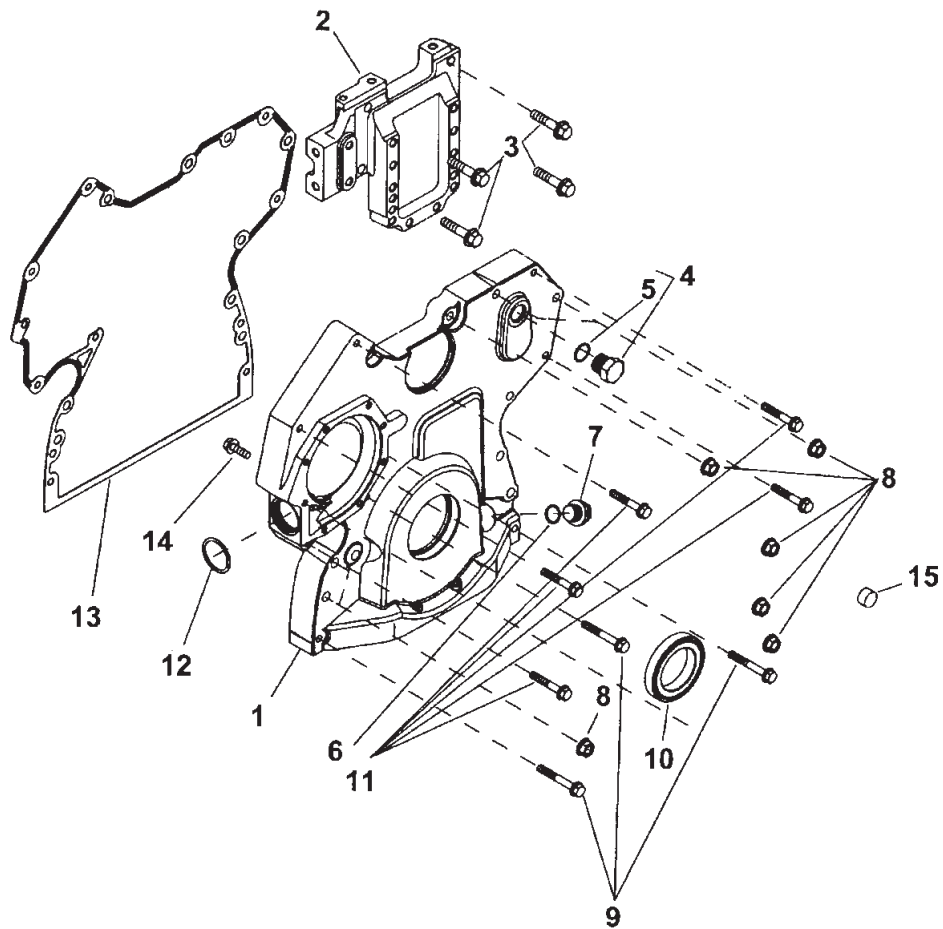

Reproduced by permission of Deere & Co., c2005. Deere & Company. All rights reserved.

RE516919SPA

KEY	PART NUMBER	QTY	DESCRIPTION	SERIAL NUMBER
1	RE503769	1	Timing Gear Cover	-
2	R516557	1	Adapter	-
3	19M7805	4	Capscrew, M10 x 45 mm	-
4	RE46687	1	Drain Plug	-
5	51M7045	1	O-ring	-
6	51M7044	1	O-ring	-
7	RE501938	1	Plug	-
8	14M7296	9	Flange Nut	-
9	19M7801	3	Capscrew, M8 x 60 mm	-
10	RE516340	1	Bearing Kit	-
11	19M7800	5	Screw	-
12	R504734	1	O-ring	-
13	R502954	1	Gasket	-
14	19M7867	1	Capscrew, M8 x 25 mm	-
15	RE46687	1	Drain Plug	-

Oil Filter Assembly L1064D- T1

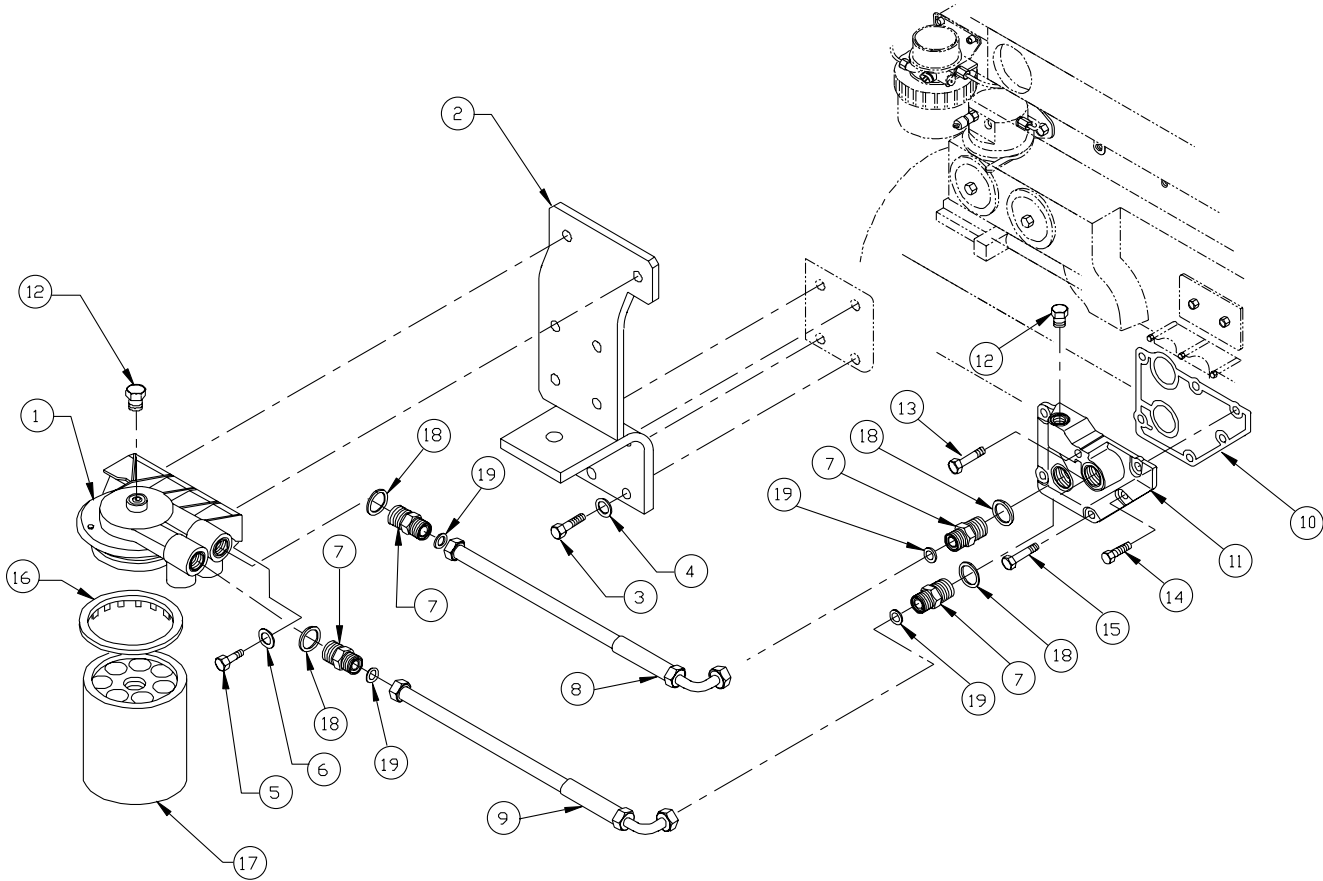

A-10570/ B-6229

Oil Filter Assembly L1064D - T1

KEY	PART NUMBER	QTY	DESCRIPTION	SERIAL NUMBER
1	RE505216	1	Oil Filter Head Assembly (includes key #16)	-
2	23-89401	1	Bracket, Rear Engine & Oil Filter (see Engine Mounting)	-
3	12-00954	4	Capscrew, Hex Head, M12 x 1.75 x 35 mm	-
4	15-00912	4	Lock Washer, Helical M12	-
5	12-00831	2	Cap Screw, Hex Head, M10 x 1.5 x 25 mm	-
6	15-00804	2	Wave Washer, M10	-
7	21-09504	4	Male Connector, Steel, 1-14 O-Ring Face Seal (Includes keys 18-19)	-
8	18-09401	1	Hose Assembly, 1/2" I.D. x 16"	-
9	18-09601	1	Hose Assembly, 1/2" I.D. x 18"	-
10	R123525	1	Gasket	-
11	RE520814	1	Adapter	-
12	RE52242	**	Plug	-
13	19M7913	1	Capscrew, M8 x 90	-
14	RE67238	1	Capscrew, M8 x 20 (with pre-applied sealant)	-
15	19M7802	4	Capscrew, M8 x 65	-
16	R502513	1	Sealing Ring	-
17	RE504836	1	Oil Filter	-
18	16-09501	**	O-ring	-
19	16-09502	**	O-ring	-
			** As required	

Oil Filter Assembly L1064A

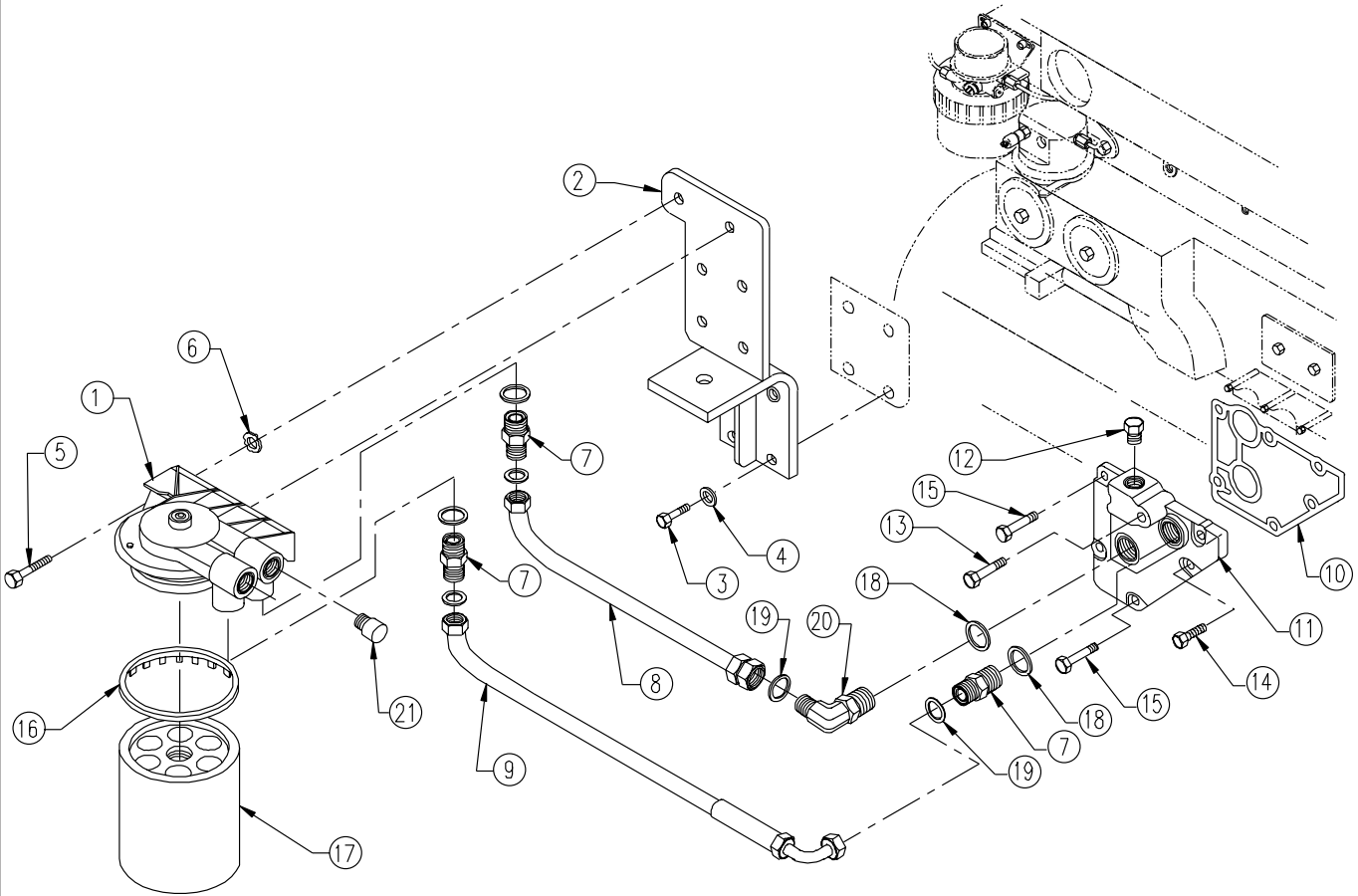

A-10665 / B-8596

Oil Filter Assembly L1064A

KEY	PART NUMBER	QTY	DESCRIPTION	SERIAL NUMBER
1	31-79501	1	Adapter	
2		1	Bracket, Rear Engine & Oil Filter (see Engine Mounting)	-
3	12-00954	4	Capscrew, Hex Head, M12 x 1.75 x 35 mm	-
4	15-00912	4	Lock Washer, Helical M12	-
5	12-00831	2	Capscrew, Hex Head, M10 x 1.5 x 25 mm	-
6	15-00804	2	Wave Washer, M10	-
7	21-09504	3	Male Connector, Steel, 1-14 O-Ring Face Seal	-
8	18-09402	1	Hose Assembly, 1/2" I.D. x 21"	-
9	18-09403	1	Hose Assembly, 1/2" I.D. x 25"	-
10	R123525	1	Gasket	-
11	RE520814	1	Adapter (formerly #RE71062)	
12	RE52242	**	Plug	-
13	19M7913	1	Capscrew, M8 x 90	-
14	RE67238	1	Capscrew, M8 x 20 (with pre-applied sealant)	-
15	19M7802	4	Capscrew, M8 x 65	-
16	R502513	1	Gasket	-
17	RE504836	1	Oil Filter	-
18	16-09501	**	O-ring	-
19	16-09502	**	O-ring	-
20	21-09505	1	Male Elbow, 90° Steel 1-14 O-ring Face Seal	
21	21-79503	1	Plug	-
			** As required	

Oil Filter and Adapter

M- NL1064D- T1, M40C2, & M55C2

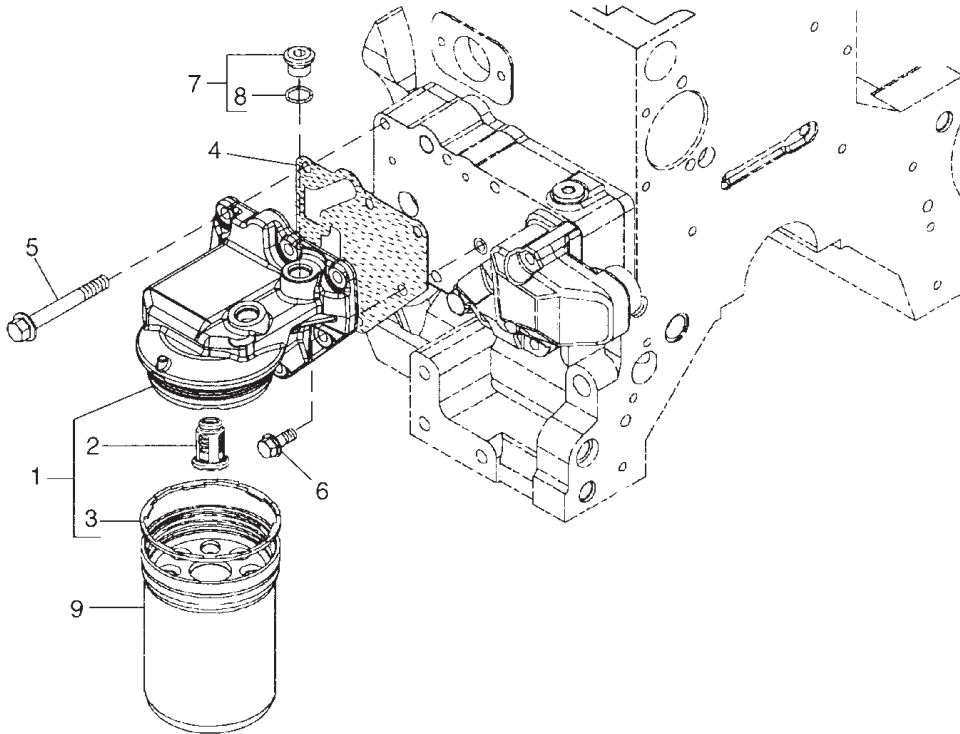

Reproduced by permission of Deere & Co., c2005. Deere & Company. All rights reserved.

RGP8909

KEY	PART NUMBER	QTY	DESCRIPTION	SERIAL NUMBER
1	RE504562	1	Filter Head (marked R502338, includes keys #2-3)	-
2	RE504543	1	Valve	-
3	R502513	1	Seal	-
4	R501484	1	Gasket	-
5	19M7802	5	Capscrew, M8 x 65 mm	-
6	RE67238	1	Capscrew, M8 x 20 mm	-
7	RE52242	**	Plug, M16 x 1.5 (includes key #8)	-
8	51M7042	**	O-ring	-
9	RE504836	1	Oil Filter	-
			**As required	

Oil Pump

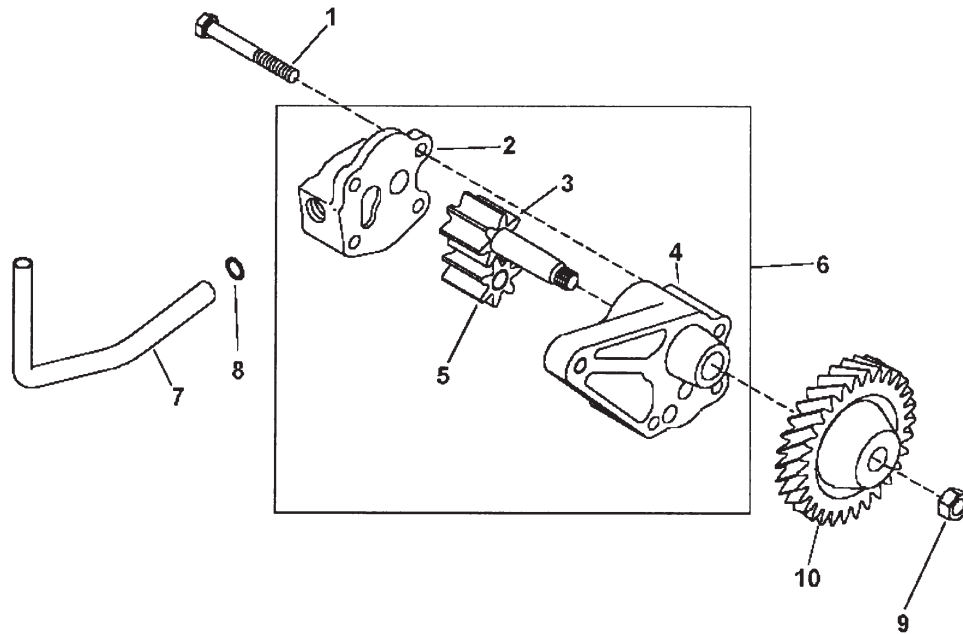

Reproduced by permission of Deere & Co., c2005. Deere & Company. All rights reserved.

RGP6223

KEY	PART NUMBER	QTY	DESCRIPTION	SERIAL NUMBER
1	19M8987	2	Capscrew, M8 x 65	-
2		1	Cover (not available separately)	-
3		1	Gear (not available separately)	-
4		1	Housing (not available separately)	-
5		1	Gear (not available separately)	-
6	RE504914	1	Oil Pump (marked R502687, includes keys #2-5)	-
7	R121376	1	Tube	-
8	R97185	1	O-ring	-
9	14M7066	1	Nut, M12	-
10	R120638	1	Gear	-

Oil Pan, Aluminum

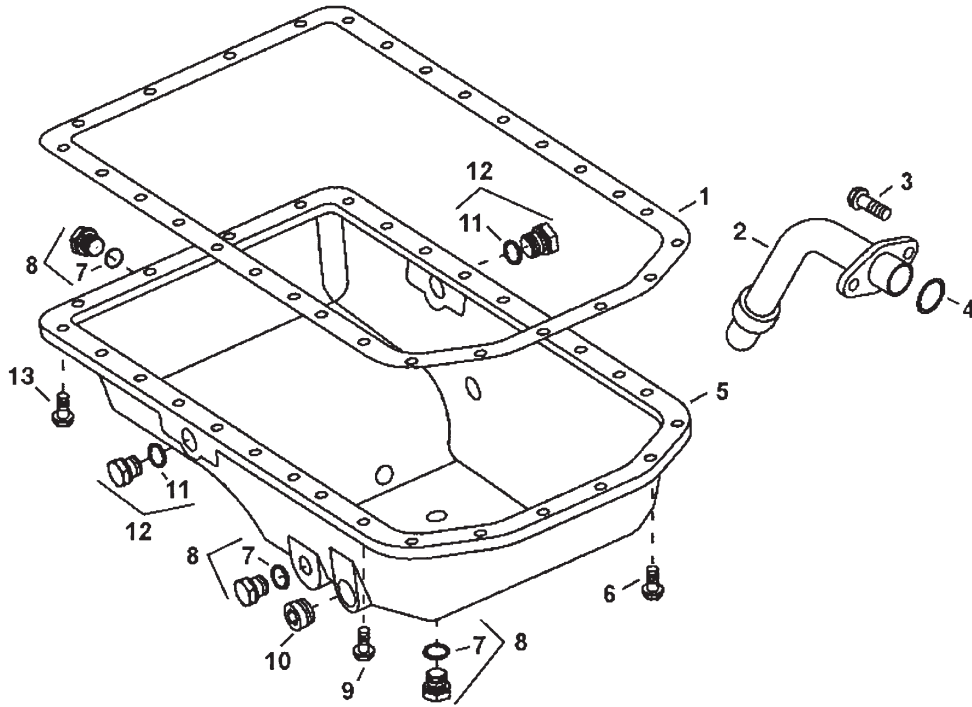

Reproduced by permission of Deere & Co., c2005. Deere & Company. All rights reserved.

RG7715

KEY	PART NUMBER	QTY	DESCRIPTION	SERIAL NUMBER
1	R123353	1	Gasket	-
2	RE57619	1	Oil Pump Intake	-
3	19M8986	2	Capscrew, M8 x 100 mm	-
4	R61871	1	O-ring	-
5	R121621	1	Oil Pan	-
6	19M7868	6	Capscrew, M8 x 30 mm	-
7	51M7043	3	O-ring	-
8	RE46685	3	Plug	-
9	19M7867	18	Capscrew, M8 x 25 mm	-
10	15H690	1	Pipe Plug	-
11	51M7045	2	O-ring	-
12	RE46687	2	Drain Plug	-
13	19M7799	4	Capscrew, M8 x 45 mm	-

Oil Pan, Steel

L -M -NL1064D, M -NL1064T1 & T2, M40C2, M55C2, & M65C2

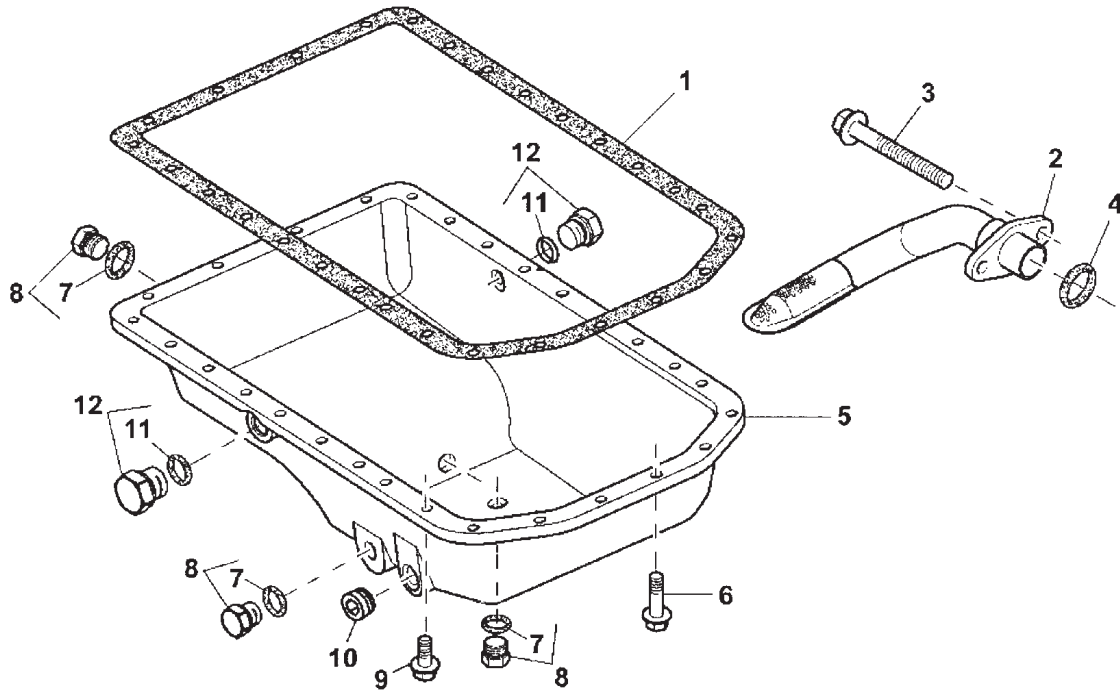

Reproduced by permission of Deere & Co., c2005. Deere & Company. All rights reserved.

CDP45979

KEY	PART NUMBER	QTY	DESCRIPTION	SERIAL NUMBER
1	R123353	1	Gasket	-
2	RE57619	1	Oil Pump Intake	-
3	19M8986	2	Capscrew, M8 x 100 mm	-
4	R61871	1	O-ring	-
5	RE520147	1	Oil Pan	-
6	19M7866	6	Capscrew, M8 x 20 mm	-
7	51M7043	1	O-ring	-
8	RE46685	3	Plug	-
9	19M8163	22	Capscrew, M8 x 16 mm	-
10	15H690	1	Pipe Plug	-
11	51M7045	1	O-ring	-
12	RE46687	2	Drain Plug, M22 x 1.5	-

GROUP 1 - ENGINE

Oil Pan

L - M1064A & H, NL1064H2

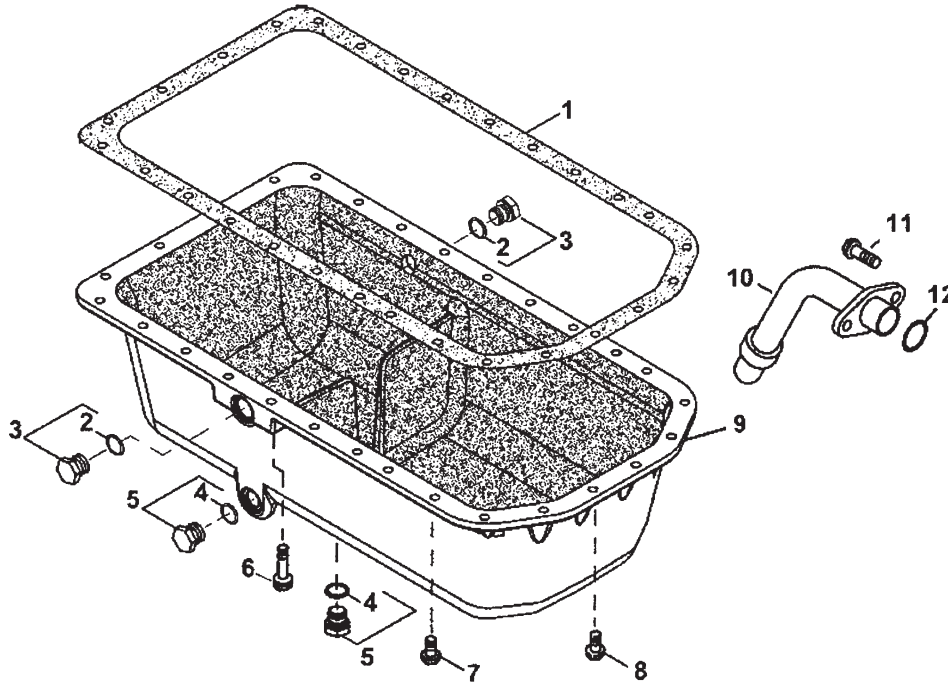

Reproduced by permission of Deere & Co., c2005. Deere & Company. All rights reserved.

RGP8206

KEY	PART NUMBER	QTY	DESCRIPTION	SERIAL NUMBER
1	R123353	1	Gasket	-
2	51M7045	2	O-ring	-
3	RE46687	2	Drain Plug, M22 x 1.5 mm	-
4	16-09503	2	O-ring	-
5	RE46685	2	Plug, M18 x 1.5 mm	-
6	19M7799	4	Cap screw, M8 x 45 mm	-
7	19M7867	18	Cap screw, M8 x 25 mm	-
8	12-80753	**	Cap screw M8 x 30 mm	-
9	R503784	1	Oil Pan (20.5 qts)	-
10	RE68491	1	Oil Pump Intake	-
11	19M8986	2	Screw M8 x 100mm	-
12	R61871	1	O-ring	-
			** as required	

Oil Drain Assembly

M1064D, T1, T2, M40C2, M55C2, & M65C2

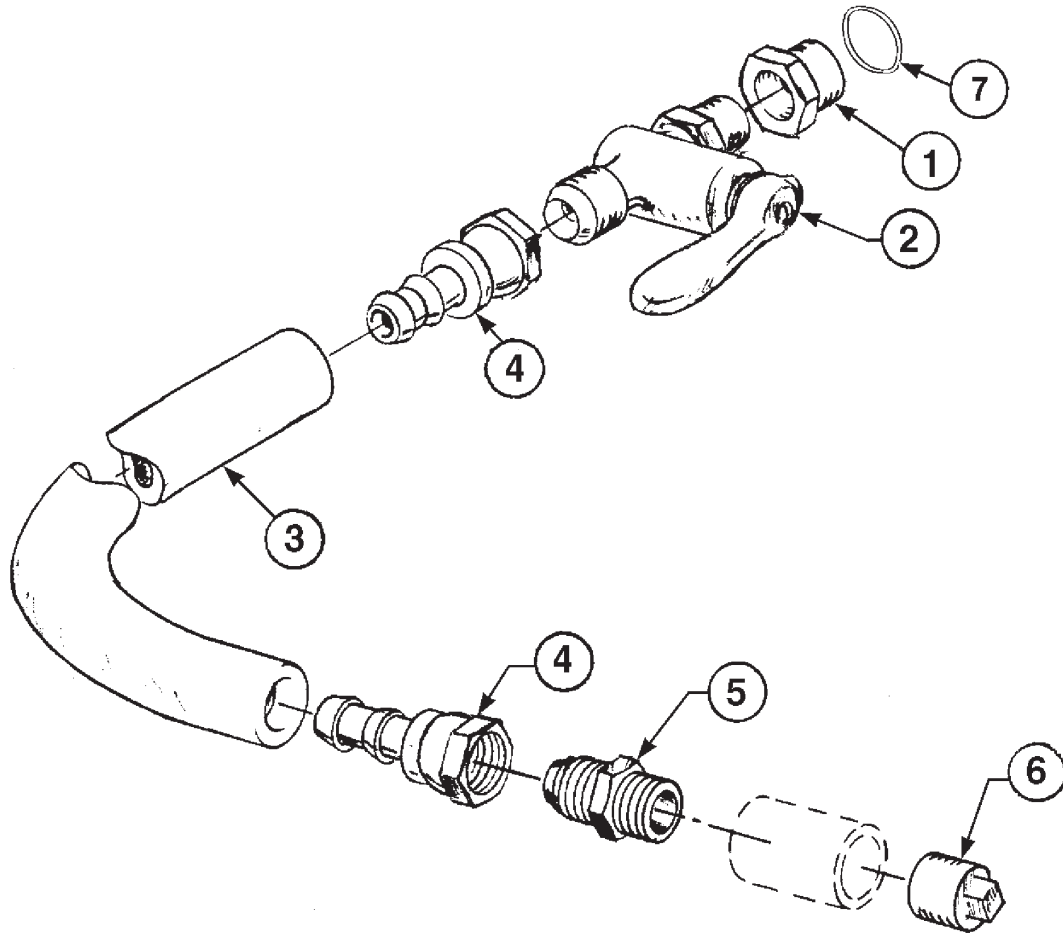

A-8361/ B-1907

KEY	PART NUMBER	QTY	DESCRIPTION	SERIAL NUMBER
1	21-70014	1	Female Adapter, Steel, 3/8 NPT x M18 x 1.5	-
2	36-71002	1	Shut Off Valve, 3/8 NPT x 1/2-45T	-
3	41-01032	16	Hose, 1/2" ID Push-on	-
4	21-71042	2	Female Swivel Brass, 1/2 Hose Barb x 1.2-45T	-
5	21-71040	1	Male Connector Brass, 1/2 NPT x 1/2-45T	-
6	21-10005	1	Plug, Hex Head, Steel, 1/2 NPT	-
7	16-09503	1	O-ring	-

Oil Drain Assembly M1064A-H

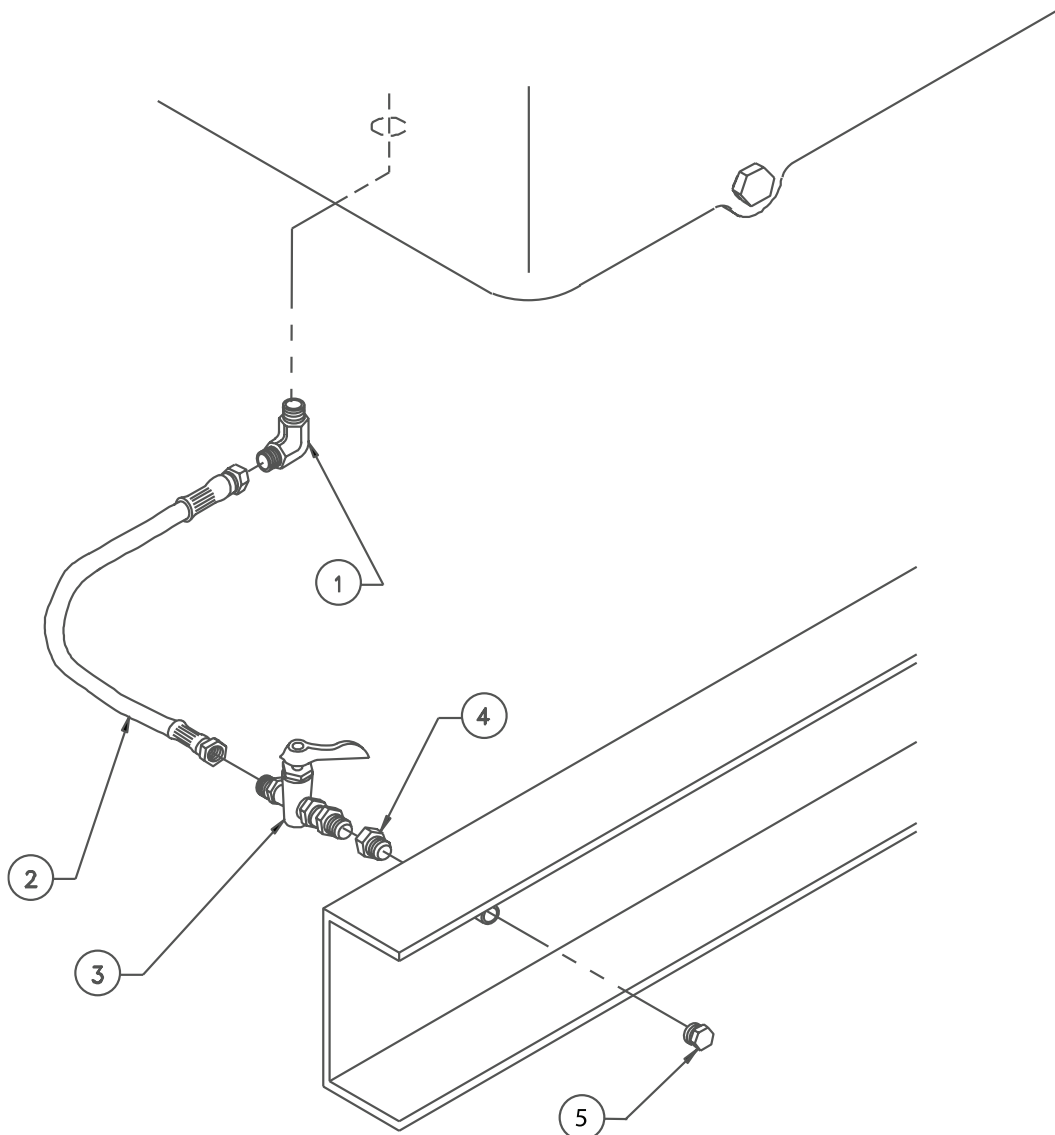

A-10827/ B-8683

KEY	PART NUMBER	QTY	DESCRIPTION	SERIAL NUMBER
1	21-79603	1	Male Elbow, 90° Steel M18 x 1.5 x 1/2- 37T	-
2	18-61002	1	Hose Assembly 1/2" I.D. x 21"	-
3	36-71002	1	Shut-off Valve, Brass 3/8 NPT x 1/2- 4	-
4	21-09513	**	Bulkhead Union, Steel 3/8 NPT	-
5	21-31003	1	Plug, Hex Head Brass 3/8 NPT	-
			**As required	

Dipstick & Tube (Right or Left Hand)

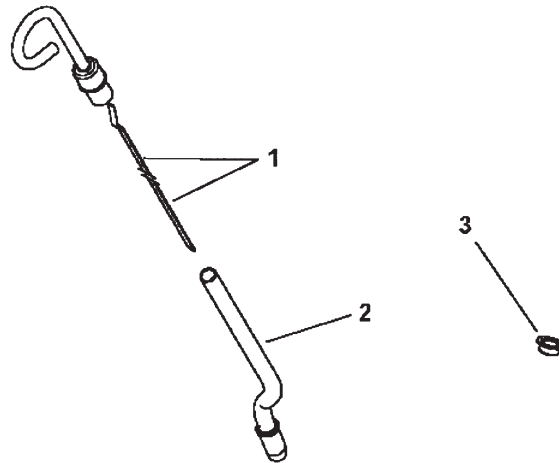

Reproduced by permission of Deere & Co., c2005. Deere & Company. All rights reserved.

RGP6190

KEY	PART NUMBER	QTY	DESCRIPTION	SERIAL NUMBER
1	RE69243	1	Dipstick	-
2	R502604	1	Dipstick Tube, Right Hand	-
	R130055	1	Dipstick Tube, Left Hand	-
3	R502725	**	Plug	-
			**As required	

Oil Fill Assembly, Right or Left Hand

Marine & Propulsion Units

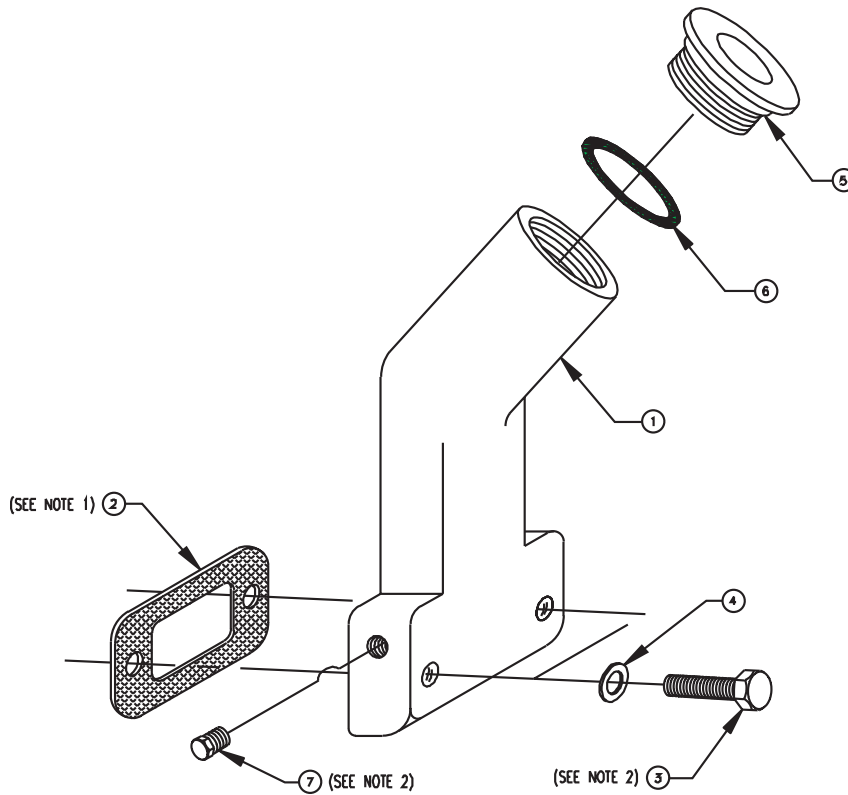

ASSEMBLY NOTES

1. INSTALL ITEM 2 WITH PREAPPLIED SEALANT TOWARDS ENGINE BLOCK.
2. INSTALL ITEMS 3 AND 7 WITH LOCTITE 567 (PST).

A-8347/ B-5846

KEY	PART NUMBER	QTY	DESCRIPTION	SERIAL NUMBER
1	36-01002	1	Oil Filler Neck	-
2	11-79501	1	Oil Filler Mounting Gasket	-
3	12-00714	2	Capscrew, Hex Head M8 x 1.25 x 40 mm	-
4	15-00701	2	Flat Washer, M8	-
5	198436010	1	Oil Fill Cap	-
6	052300400	1	O-Ring	-
7	21-00012	**	Plug, Hex Head, Brass, 1/8 NPT	-
			** As required	

Oil Fill Assembly, Left Side (with Governor Actuator)

M1064D-T1, M40C2, M55C2 and Oil Fill Block-off, Left or Right Side, All Models

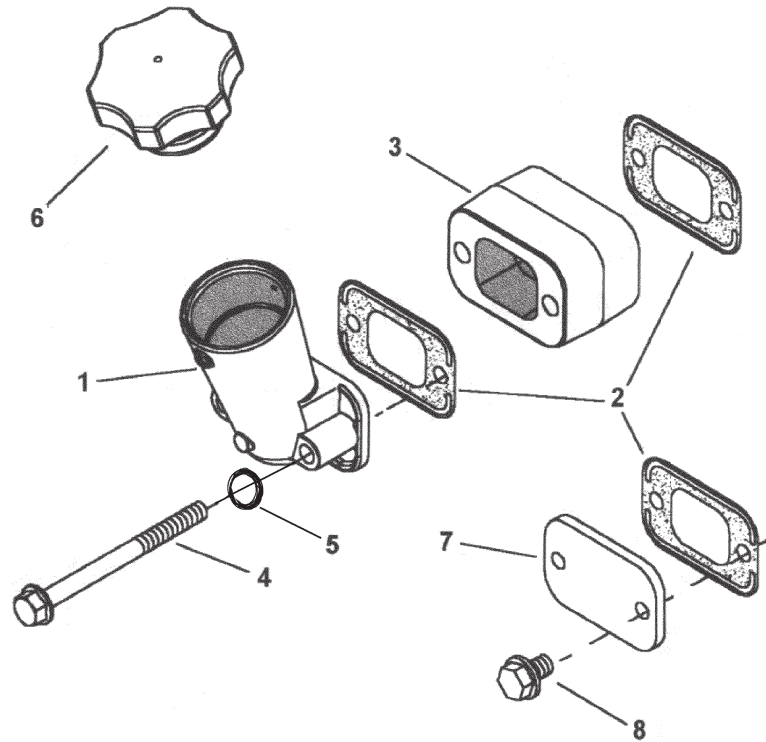

Reproduced by permission of Deere & Co., c2005. Deere & Company. All rights reserved.

RGP5993

KEY	PART NUMBER	QTY	DESCRIPTION	SERIAL NUMBER
1	RE501377	1	Filler Neck	-
2	11-79501	4	Gasket	-
3	R136514	1	Spacer	-
4	6132-11-4690	2	Capscrew, Hex Head M8 x 1.25 x 115 mm	-
5	15-00805	2	Flat Washer M8	-
6	RE500005	1	Filler Cap	-
7	R116296	1	Plate	-
8	RE67238	2	Screw, M8 x 20 (with pre-applied sealant)	-
9	21-79502	1	Spacer (use with actuator bracket, not shown)	-

GROUP 1 - ENGINE

Low Oil Level Switch/Gauge, ISO Ground R.H.

M1064T2 @ 50 Hz - M1064A-H - NL1064H43

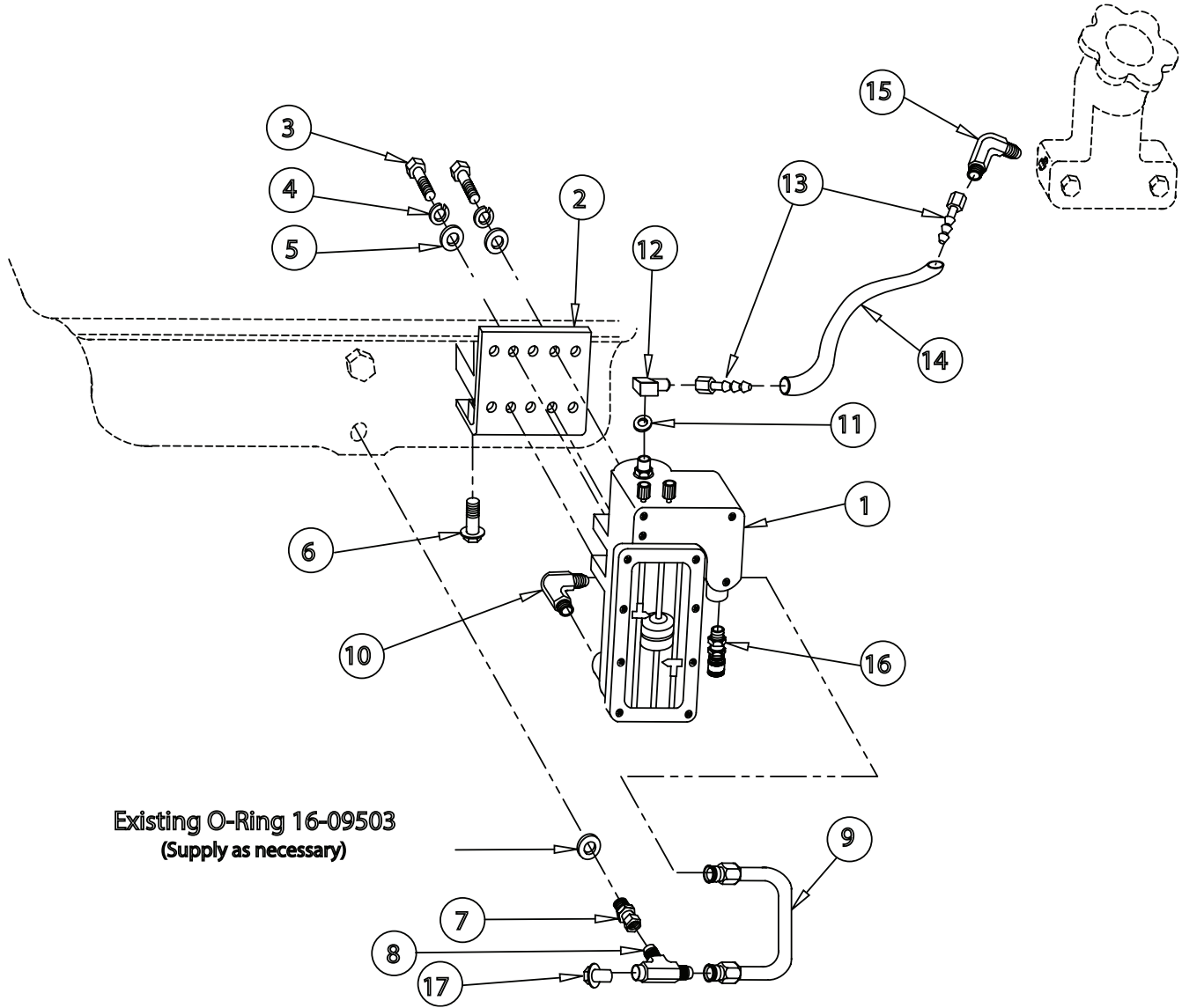

B8619A

Low Oil Level Switch/Gauge, ISO Ground R.H.

M1064T2 @ 50 Hz - M1064A-H - NL1064H43

KEY	PART NUMBER	QTY	DESCRIPTION	SERIAL NUMBER
1	22-10004	1	Oil Level Switch/Gauge, ISO Ground	-
2	23-71018	1	Bracket, Oil level Switch Gauge RH (Cast Oil Pan)	-
3	12-00111	4	Capscrew, Hex Head 1/4-20 x 3/4"	-
4	15-00102	4	Lock Washer, Helitical 1/4	-
5	15-00008	4	Flat Washer M6	-
6	01435-00855	2	Capscrew, Hex Head Flanged M8 x 1.5 x 55mm Grade 10.9	-
7	21-79601	1	Female Swivel, STL M18 x 1.5 x 3/8-37T	-
8	21-79604	1	female Run Tee, STL. 3/8 NPT x 3/8-37T	-
9	27-09404	1	Tube Assembly, Low oil Level SW/GA	-
10	21-70011	1	Male Elbow, 90 STL, 1/2 NPT x 3/8-37 T	-
11	15-09805	1	Flat Washer M10 S/S (316) Din Code 125-A4	-
12	21-92200	1	Female Elbow, 90, BRS 1/8 NPT x 1/4-45 T	-
13	21-71045	2	Female Swivel, BRS 1/4 HB x 1/4-45 T Push-On (Universal Seat)	-
14	41-01011	9	Hose 1/4" ID Push-On	-
15	21-52204	1	Male, Connector, BRS 1/8 NPT x 1/4-45 T	-
15	21-71043	1	Male Elbow 90, BRS 1/8 NPT x 1/4-45 T	-
16	00-40016	1	Strain Relief Connection 1/2 NPT with 3/16" ID to 5/16" Grommet	-
17	21-31003	1	Plug, Hex Head BRS, 3/8 NPT	-

Cylinder Head

L- M1064D, M- NL1064T1-T2, L- M1064A, NL1064H1, M40C2, M55C2, & M65C2

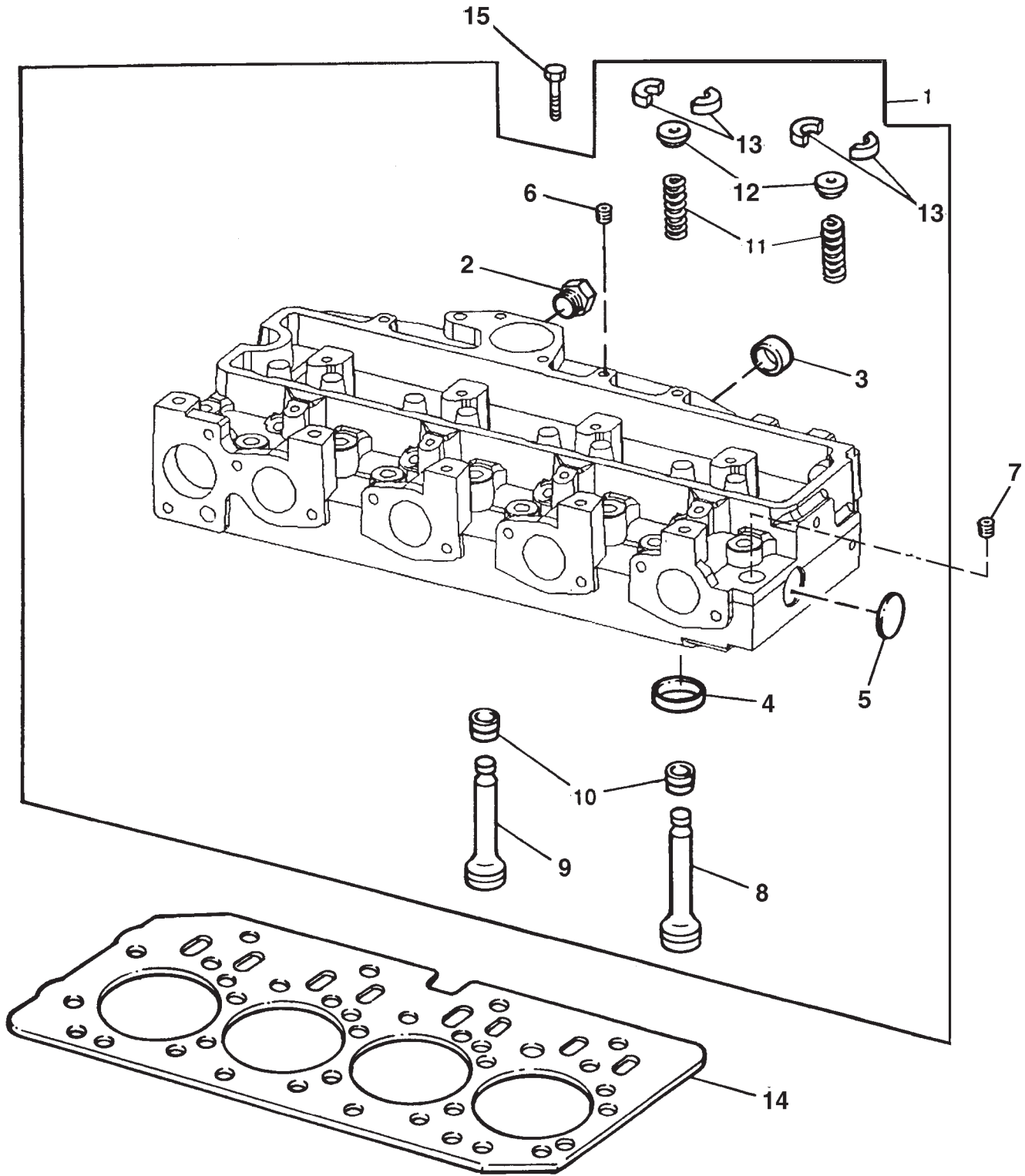

Cylinder Head

L- M1064D, M- NL1064T1-T2, L- M1064A, NL1064H1, M40C2, M55C2, & M65C2

KEY	PART NUMBER	QTY	DESCRIPTION	SERIAL NUMBER
1	RE57234	1	Cylinder Head (marked R121402, includes keys 2-6 & 8-13)	-
2	21-09507	**	Plug	-
	R26906	1	O-ring	-
3	R43409	2	Cap	-
4	R98063	4	Valve Seat Insert, Standard Size Intake Valve	-
	R98335	**	Valve Seat Insert, Oversize Intake Valve	-
	R106831	4	Valve Seat Insert, Standard Size Intake Valve	-
	R85687	4	Valve Seat Insert, Standard Size Exhaust Valve	-
	R93910	**	Valve Seat Insert, Oversize Exhaust Valve	-
	R106829	4	Valve Seat Insert, Standard Size Exhaust Valve	-
5	CD16284	1	Cap	-
6	R104592	1	Pipe Plug, 1/8"	-
7	15H624	1	Pipe Plug, 1/2"	-
8	R98062	4	Intake Valve, Standard	-
	R97490	**	Intake Valve, .015" Oversize	-
	R97491	**	Intake Valve, .030" Oversize	-
9	R90692	4	Exhaust Valve, Standard	-
	R97492	**	Exhaust Valve, .015" Oversize	-
	R97493	**	Exhaust Valve, .030" Oversize	-
10	RE31617	8	Seal	-
11	R26125	8	Spring	-
12	RE60005	8	Rotater	-
13	R91889	16	Retainer	-
14	R116515	1	Head Gasket	-
15	R85363	18	Capscrew 1/2" x 112 mm	-
			**As required	

Cylinder Head

M1064H, NL1064H2

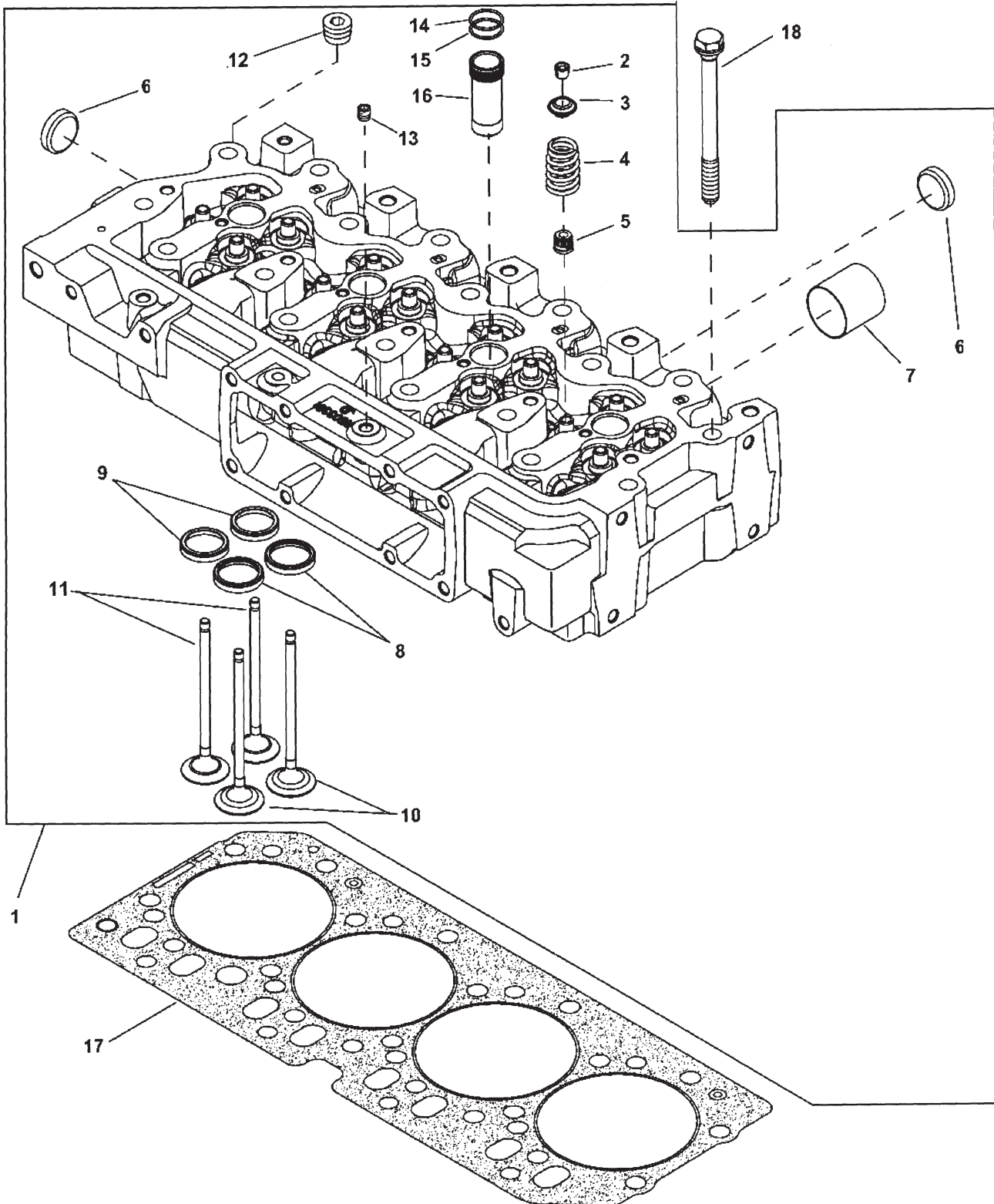

Cylinder Head

M1064H, NL1064H2

KEY	PART NUMBER	QTY	DESCRIPTION	SERIAL NUMBER
1	RE509803	1	Cylinder Head (marked R503381, includes keys 2-17)	-
2	R502371	32	Keep	-
3	R502367	16	Retainer	-
4	R503906	16	Valve Spring	-
5	RE519115	16	Seal	-
6	CD16284	4	Plug	-
7	R502512	4	Sleeve	-
8	R515033	8	Valve Seat Insert, Exhaust	-
9	R515034	8	Valve Seat Insert, Intake	-
10	R502369	8	Intake Valve	-
11	R502370	8	Exhaust Valve	-
12	15H624	4	Pipe Plug	-
13	R104592	1	Pipe Plug	-
14	RE528349	4	O-ring	-
15	RE530609	4	O-ring	-
16	RE517435	4	Sleeve (includes keys #14-15)	-
17	R116515	1	Cylinder Head Gasket	-
18	R502511	18	Screw	-

GROUP 1 - ENGINE

Rocker Shaft Assembly & Push Rods

L- M- NL1064D, M- NL1064T1, T2, L- M1064A, NL1064H1, M40C2, M55C2, & M65C2

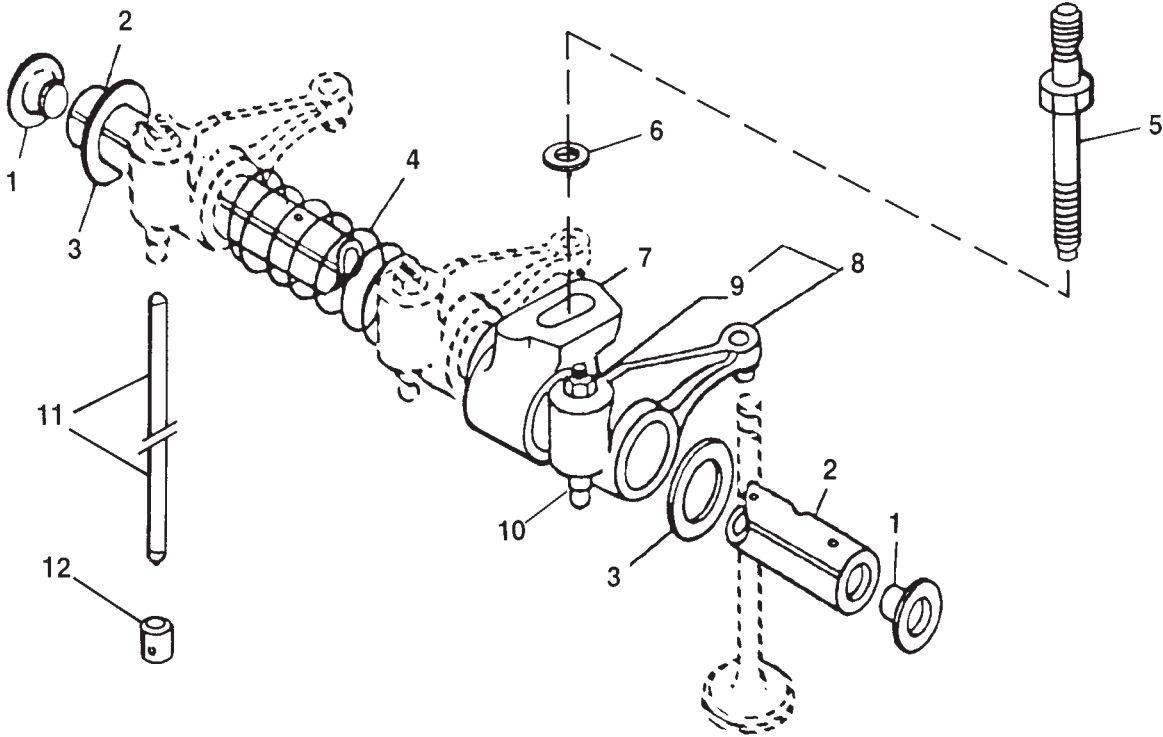

Reproduced by permission of Deere & Co., c2005. Deere & Company. All rights reserved.

TP49263

KEY	PART NUMBER	QTY	DESCRIPTION	SERIAL NUMBER
1	R54565	2	Plug	-
2	R123513	1	Rocker Arm Shaft	-
3	T20316	2	Washer	-
4	T20314	3	Spring	-
5	R123271	4	Stud	-
6	24M7346	4	Washer (L-M1064D & T1)	-
	R42729	4	Washer (L-M1064T2 & A)	-
7	R123161	4	Support	-
9	14M7148	1	Nut, M10	-
8	RE508317	8	Rocker Arm (includes keys 9 & 10)	-
9	14M7148	1	Nut, M10	-
10	R133630	8	Adjusting Stud	-
11	R107731	8	Push Rod	-
12	R123565	8	Cam Follower	-

Rocker Shaft Assembly & Push Rods

M1064H, NL1064H2

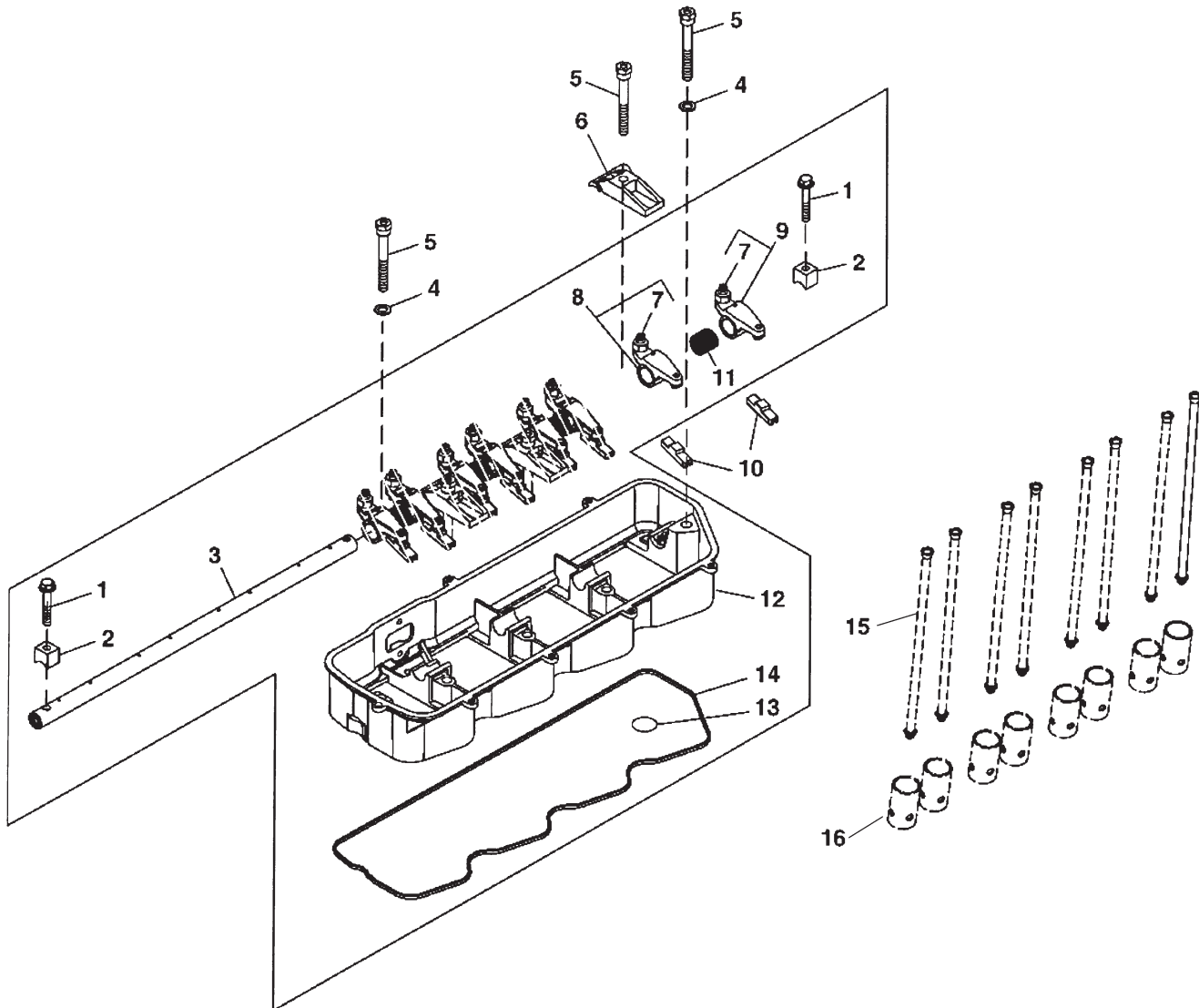

Rocker Shaft Assembly & Push Rods

M1064H, NL1064H2

KEY	PART NUMBER	QTY	DESCRIPTION	SERIAL NUMBER
••	RE519896	1	Rocker Arm Shaft Assembly (includes keys #1-3, 7-9, 11-14)	-
1	19M9170	2	Capscrew, M8 x 50	-
2	R504631	2	Starter Relay	-
3	RE516490	1	Rocker Arm Shaft	-
	30M7004	1	Cap	-
4	24M7096	**	Washer	-
5	R519292	5	Bolt (Tapped M6 x 1.0, formerly #R504636)*	-
	R521458	5	Bolt (Tapped M8 x 1.25)*	-
6	R516140	3	Strap	-
7	14M7148	1	Nut, M10	-
8	RE523023	4	Rocker Arm, Intake (replaces RE504209, includes key #7)	-
9	RE504210	4	Rocker Arm, Exhaust (includes key #7)	-
10	R502341	8	Cross Bar	-
11	R505543	8	Spring	-
12	R505159	1	Support	-
	R519740	1	Support (replaces R505159)	-
13	R47154	1	O-ring (use with R505159)	-
	R72328	1	O-ring (replaces R47154, use with R519740)	-
14	R505174	1	Gasket (marked R121402)	-
15	R504209	8	Push Rod	-
16	R123565	8	Cam Follower	-
			*See Rocker Arm Cover assembly detail	
			**As required	

Rocker Arm Cover

L - M1064D, M1064T1,T2, A, M40C2, M55C2, & M65C2

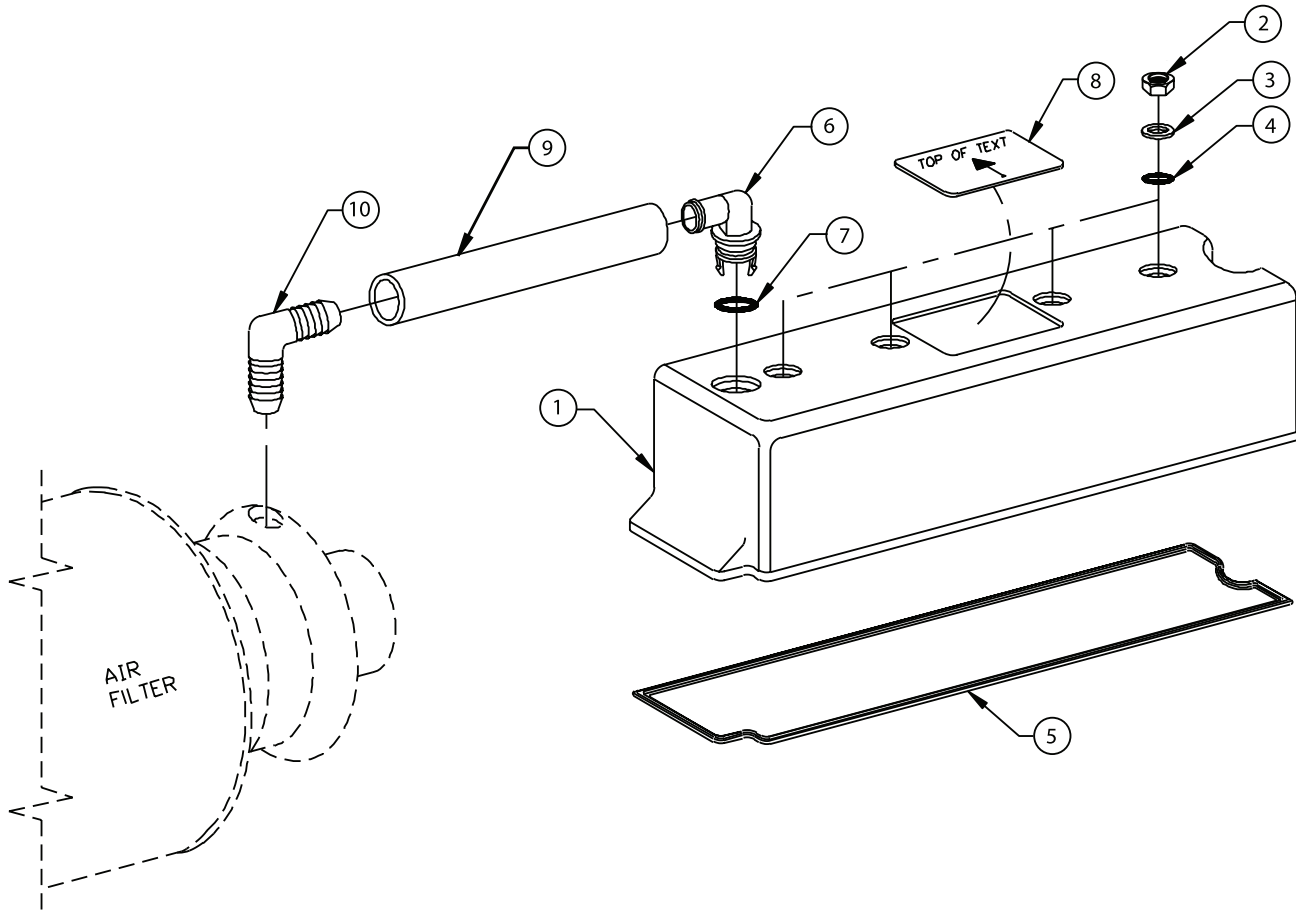

A-8281/ C-4091

KEY	PART NUMBER	QTY	DESCRIPTION	SERIAL NUMBER
1	10-09402	1	Rocker Arm Cover	-
2	14-71002	4	Hex Nut, M8 x 1.25 x 53.5 mm Special	-
3	15-09007	4	Flat Washer, M12 S/S	-
4	16-15005	4	O-ring	-
5	R123542	1	Gasket, Rocker Arm Cover Mounting	-
6	R120467	1	Elbow, Vent System Connection	-
7	16-01000	1	O-ring	-
8	00-09504	**	Label "Lugger"	-
	00-09507	**	Label "Northern Lights"	-
9	41-00004	**	Hose, 3/4" I.D. (sold per inch)	-
10	21-00025	**	Vent Elbow	-
			**As required	

Rocker Arm Cover

M1064H

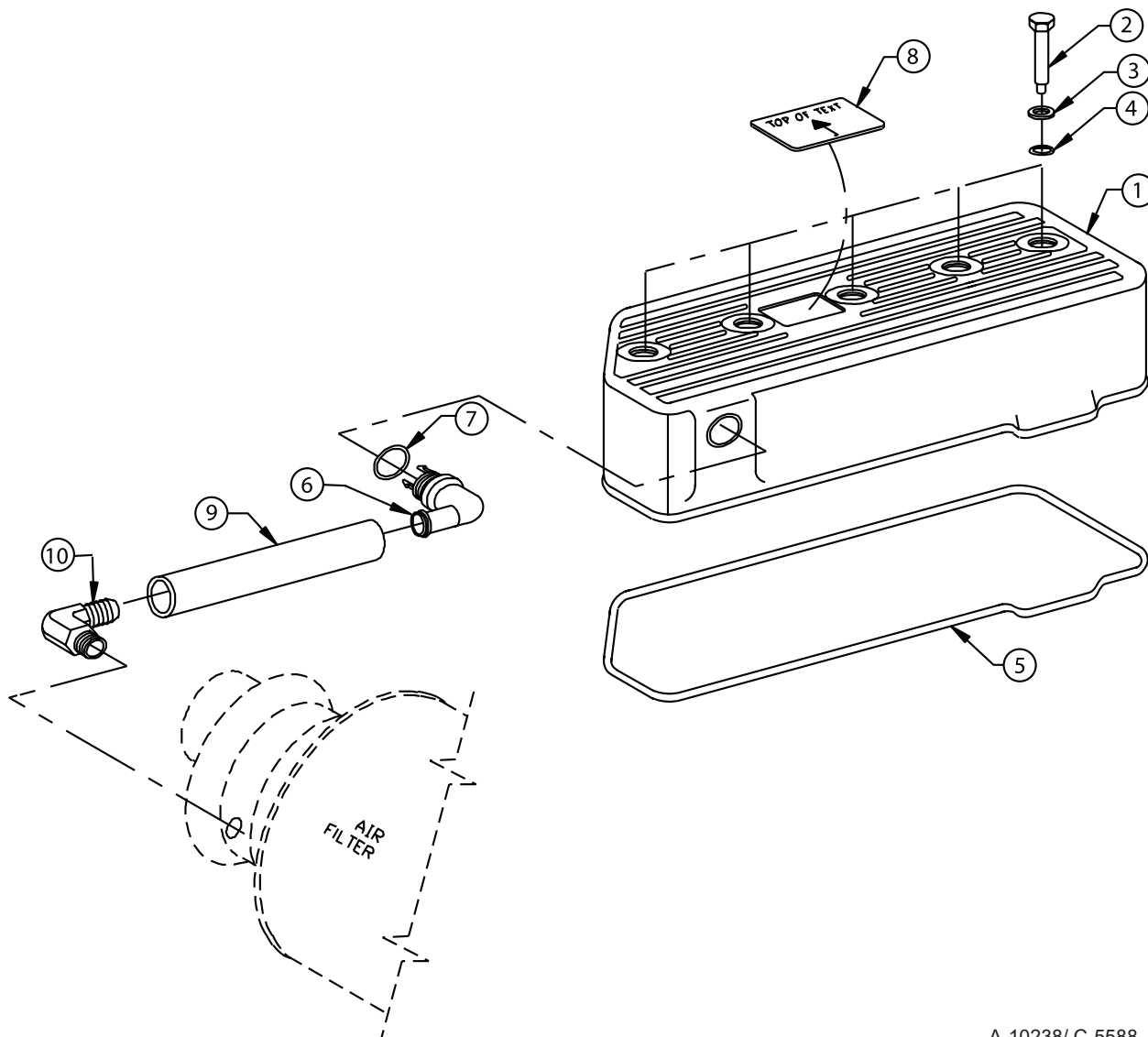

A-10238/ C-5588

KEY	PART NUMBER	QTY	DESCRIPTION	SERIAL NUMBER
1	10-09404	1	Rocker Arm Cover	-
2	12-99501	5	Capscrew, Hex Head Special M6 x 1.0 x 78.8 mm S/S*	-
	12-99502	5	Capscrew, Hex Head Special M8 x 1.25 x 78.8 mm S/S*	-
3	15-09007	5	Flat Washer, M12 S/S	-
4	16-15005	5	O-ring	-
5	R505174	1	Gasket, Rocker Arm Cover Mounting	-
6	R120467	1	Elbow, Vent System Connection	-
7	16-01000	1	O-ring	-
8	00-09507	1	Label "Northern Lights"	-
9	41-00004	**	Hose 3/4" ID (sold per inch)	-
10	21-00025	1	Vent Elbow 3/4" Hose Barb	-
*Verify thread size. See also Rocker Shaft Assembly.				

Rocker Arm Cover

NL1064D, M40C2, & NL1064T1, T2, H1

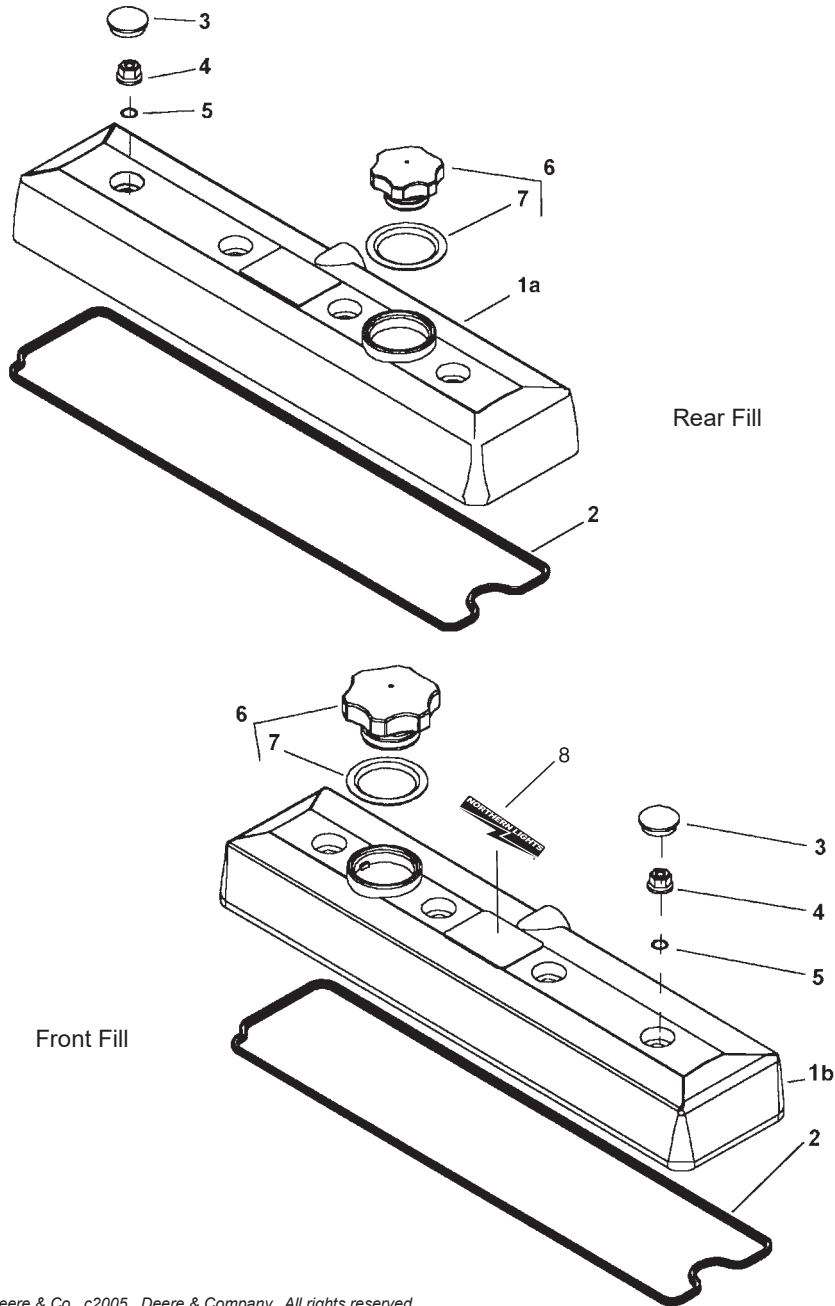

Reproduced by permission of Deere & Co., c2005. Deere & Company. All rights reserved.

RGP5989, RGP5987

KEY	PART NUMBER	QTY	DESCRIPTION	SERIAL NUMBER
1a	RE70403	1	Rocker Arm Cover, Rear Oil Fill (NL1064D, M40C2)	-
1b	RE70401	1	Rocker Arm Cover, Front Fill (NL1064T1, T2, H1)	-
2	R123542	1	Gasket	-
3	H23125	4	Plug	-
4	R123574	4	Nut	-
5	R123575	4	O-ring	-
6	RE500005	1	Filler Cap (includes key #7)	-
7	R502902	1	Packing	-
8	00-09508	1	Nameplate "Northern Lights"	-

Rocker Arm Cover

NL1064H2, Early Production

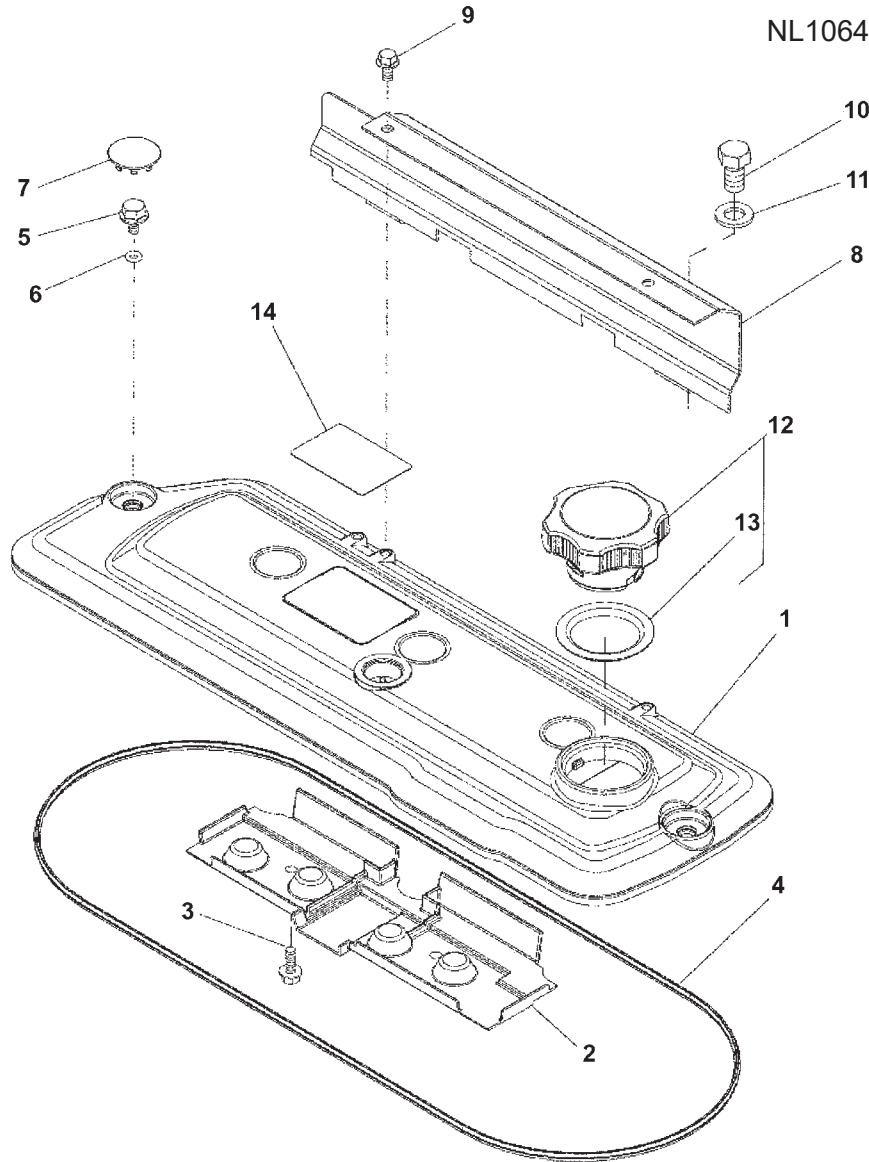

Reproduced by permission of Deere & Co., c2006. Deere & Company. All rights reserved.

RGP8822

KEY	PART NUMBER	QTY	DESCRIPTION	SERIAL NUMBER
1	R515538	1	Rocker Arm Cover	-
2	R515555	1	Deflector	-
3	19M7775	2	Capscrew, M6 x 16 mm	-
4	R524499	1	Gasket (formerly #R505174)	-
5	R516181	5	Screw, M6 x 1.0 x 12 mm*	-
6	R516158	5	O-ring	-
7	H23125	5	Plug	-
8	R516708	1	Heat Shield	-
9	19M7774	2	Capscrew, M6 x 12 mm	-
10	19M8017	2	Capscrew, M12 x 20 mm	-
11	24M7047	2	Washer	-
12	RE500005	1	Filler Cap (includes key 13)	-
13	R502902	1	Packing	-
14	00-09508	1	Nameplate "Northern Lights"	-
			*See Rocker Arm Assembly detail	-

Rocker Arm Cover

NL1064H2, Late Production

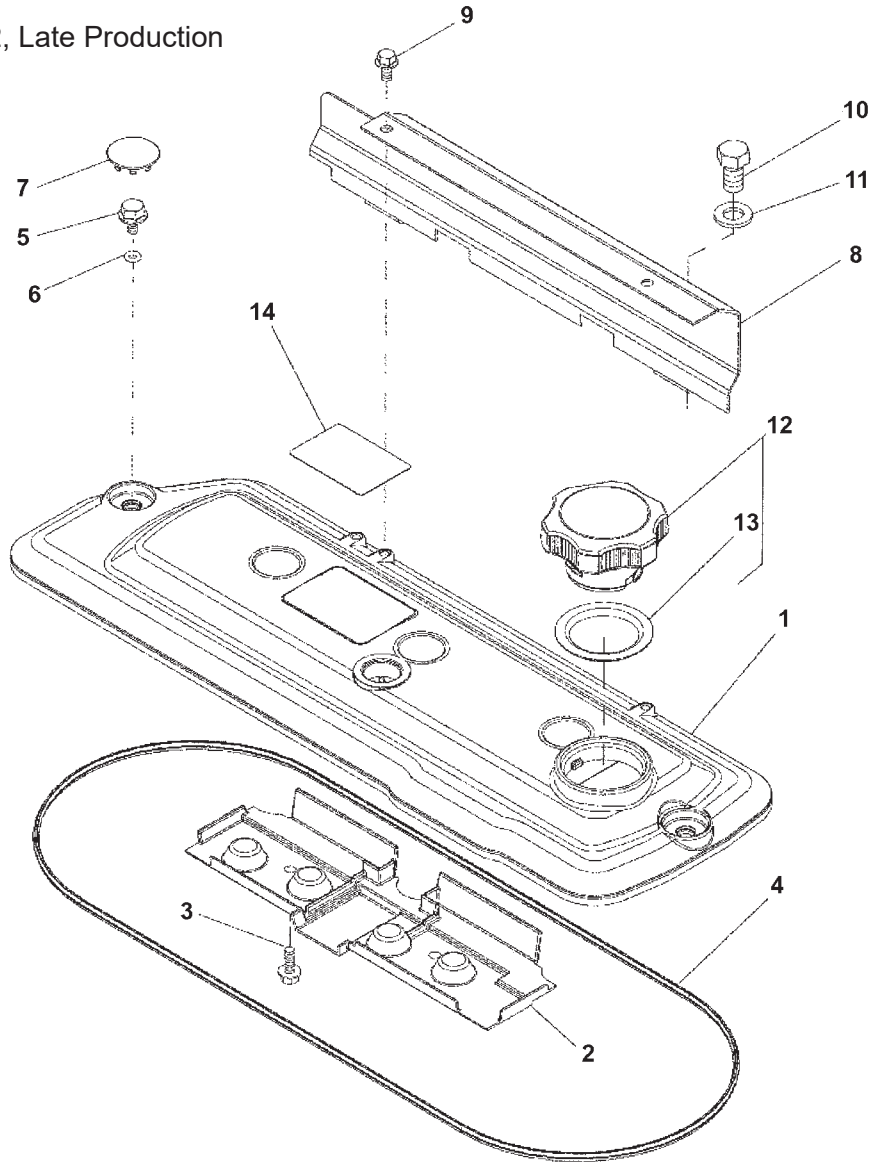

Reproduced by permission of Deere & Co., c2006. Deere & Company. All rights reserved.

RGF8822

KEY	PART NUMBER	QTY	DESCRIPTION	SERIAL NUMBER
1	R522165	1	Rocker Arm Cover	-
2	R515555	1	Deflector	-
3	19M7775	2	Cap screw, M6 x 16 mm	-
4	R524499	1	Gasket	-
5	R521390	5	Screw, M8 x 1.25 x 12 mm*	-
6	R123575	5	O-ring	-
7	H23125	5	Plug	-
8	R516708	1	Heat Shield	-
9	19M7774	2	Cap screw, M6 x 12 mm	-
10	19M7386	2	Cap screw, M12 x 20 mm	-
11	24M7047	2	Washer	-
12	RE535560	1	Filler Cap (includes key 13)	-
13	R502902	1	Packing	-
14	00-09508	1	Nameplate "Northern Lights"	-
			*See Rocker Arm Assembly detail	-

Ventilating System

NL1064D, T1, T2, H1, & H2

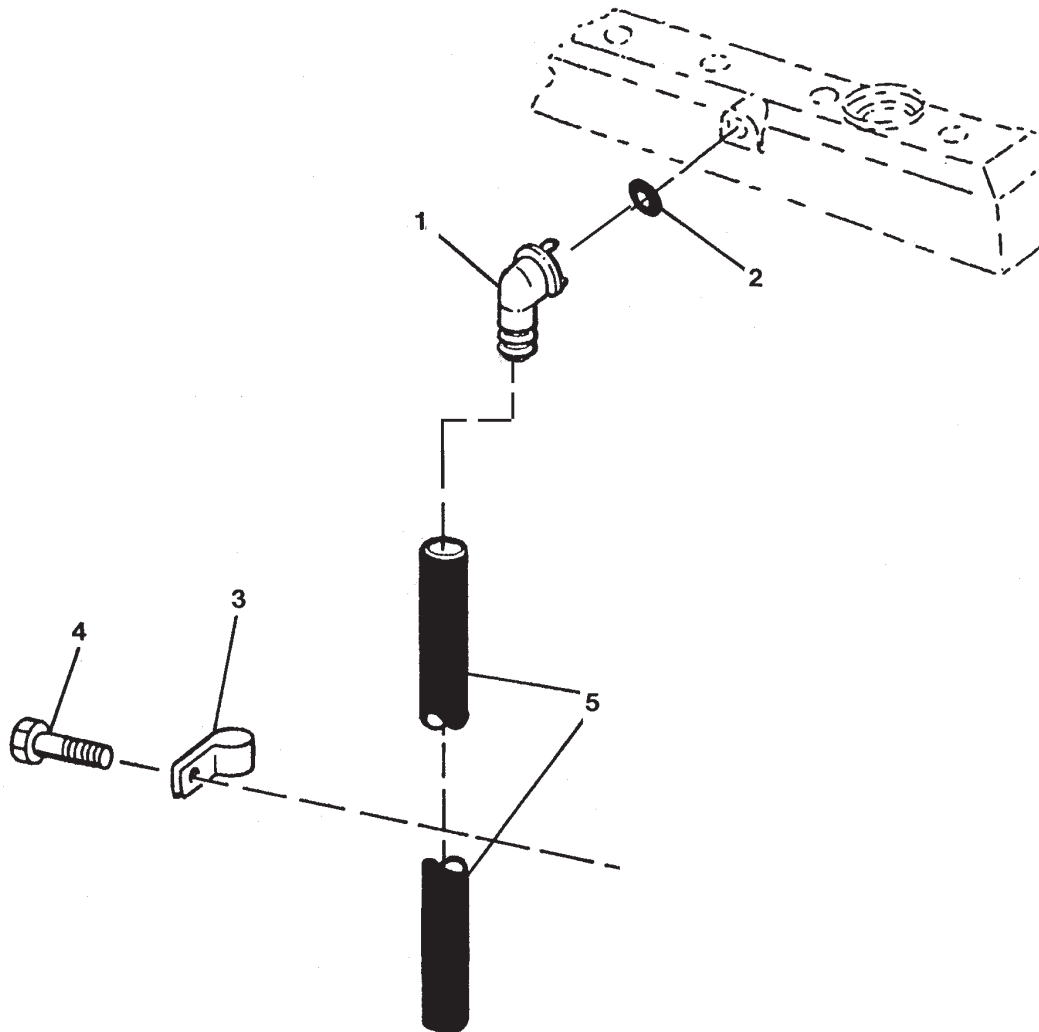

Reproduced by permission of Deere & Co., c2005. Deere & Company. All rights reserved.

TP61896

KEY	PART NUMBER	QTY	DESCRIPTION	SERIAL NUMBER
1	R120467	1	Elbow Fitting, 90°	-
2	R72328	1	O-ring	-
3	R72659	1	Clamp	-
4	19M7866	1	Capscrew, M8 x 20	-
5	41-00004	**	Hose, 3/4" I.D. (sold per inch)	-
			**As required	

Intake Manifold & Air Filter

L- M1064D, M40C2

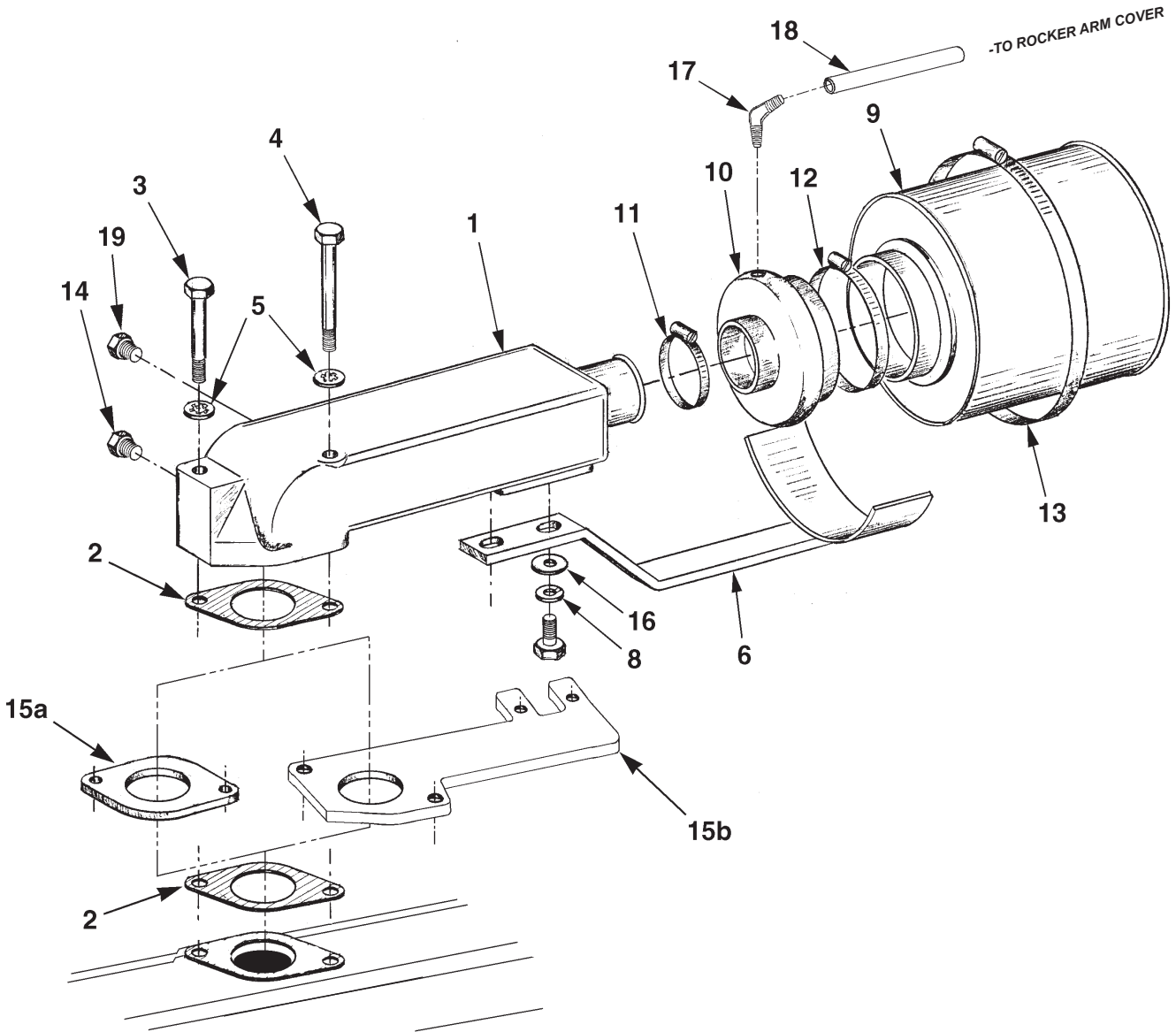

A-3821/ B-1731B

Intake Manifold & Air Filter

L- M1064D, M40C2

KEY	PART NUMBER	QTY	DESCRIPTION	SERIAL NUMBER
1	10-21400	1	Intake Manifold	-
2	11-21011	2	Gasket	-
3	12-00819	1	Capscrew, Hex Head, M10 x 1.5 x 75 mm	-
4	12-00088	1	Capscrew, Hex Head, M10 x 1.5 x 95 mm	-
5	15-00804	2	Wave Washer, M10	-
6	23-21610	1	Bracket	-
7	12-00311	2	Capscrew, Hex Head 3/8-16	-
8	15-00302	2	Lock Washer 3/8"	-
9	24-21003	1	Air Filter	-
10	18-21004	1	Hump Hose	-
11	19-00036	1	Hose Clamp #36	-
12	19-00072	1	Hose Clamp #72	-
13	19-00128	1	Hose Clamp #128	-
14	21-00012	1	Hex Plug 1/8 NPT	-
15a	28-21001	1	Spacer (M1064)	-
15b	23-49507	1	Bracket (L1064)	-
16	15-00301	2	Flat Washer 3/8	-
17	21-00025	1	Male Elbow 90° PVC 3/4" Hose Barb	-
18	41-00004	**	Hose 3/4" I.D. (sold per inch)	-
19	21-29502	1	Plug, M14 x 1.5 O-ring	-
			**As required	

Intake and Turbocharger Assembly

L1064T1

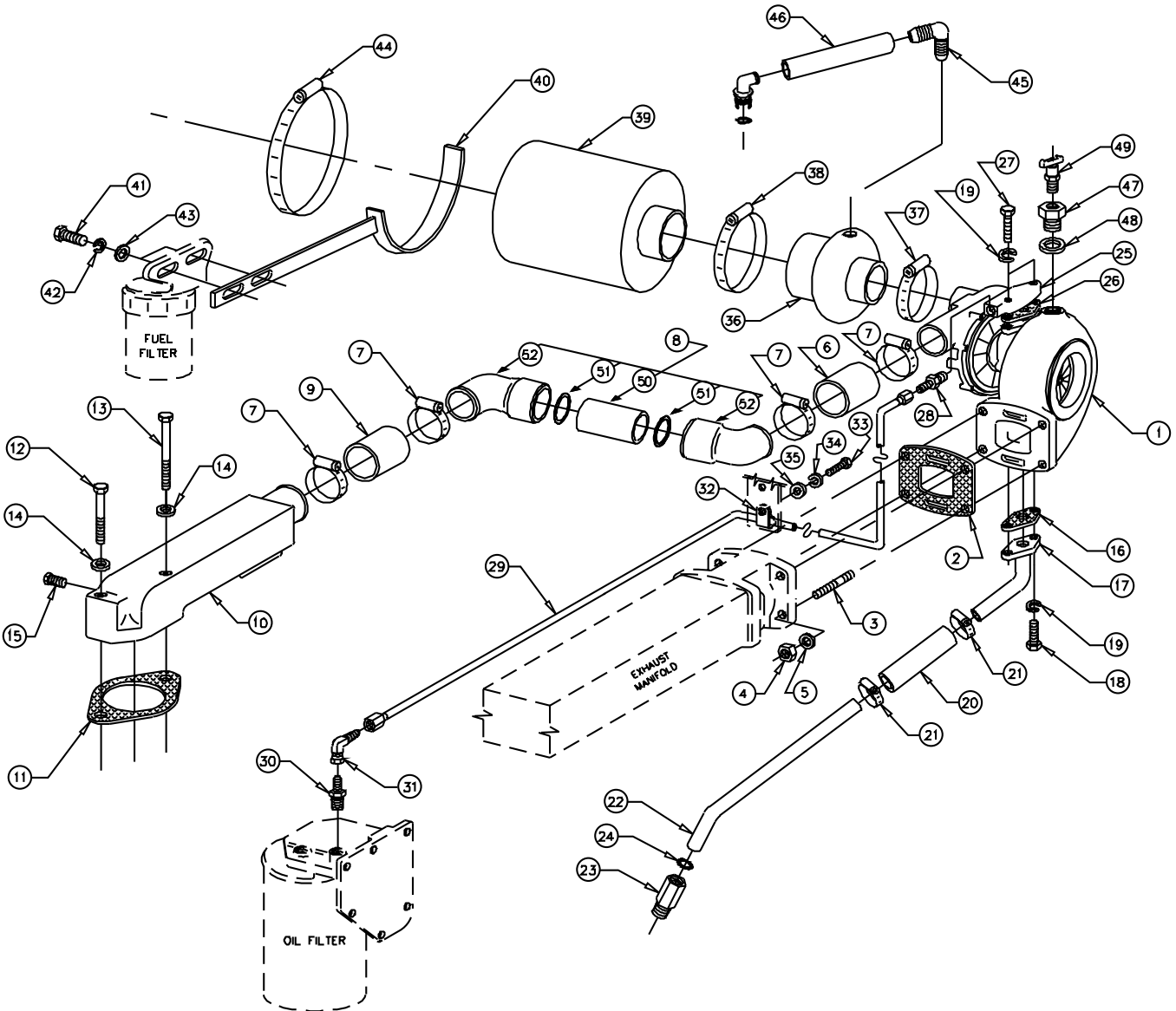

A-10587/ C-4137

Intake and Turbocharger Assembly

L1064T1

KEY	PART NUMBER	QTY	DESCRIPTION	SERIAL NUMBER
1	30-31426-1	1	Turbocharger K26 (see parts detail)	-
2	11-31401	1	Gasket	-
3	13-00814	4	Stud, M10 x 1.5 x 30 mm (42 mm LOA)	-
4	14-00817	4	Hex Nut, M10 x 1.5 S/S	-
5	15-00804	4	Wave Washer, M10	-
6	18-21016	1	Hose, 2" ID x 1- 3/4" 3 Ply Silicone	-
7	19-01028	4	Hose Clamp #28 Extended Band S/S	-
8	27-21010	1	Intake Tube Assembly (includes keys #50-52)	-
9	18-21014	1	Hose 2" ID x 2- 3/8" 3 Ply Silicone	-
10	10-21400	1	Intake Manifold	-
11	11-21011	2	Gasket, Intake Port	-
12	12-00819	1	Capscrew, Hex Head M10 x 1.5 x 75 mm	-
13	12-00088	1	Capscrew, Hex Head M10 x 1.5 x 95 mm	-
14	15-00804	2	Wave Washer M10	-
15	21-00012	1	Plug, Hex Head Brass 1/8 NPT	-
16	11-31031	1	Gasket, Turbo Oil Return	-
17	27-31602	1	Pipe, Turbo Oil Return (Upper)	-
18	12-00711	2	Capscrew, Hex Head M8 x 1.25 x 20 mm	-
19	15-00702	4	Lock Washer, Helical M8	-
20	18-11010	1	Hose 3/4" ID x 4-1/4" 3 Ply Silicone	-
21	19-01012	2	Hose Clamp #12 Extended Band S/S	-
22	27-31402	1	Pipe, Turbo Oil Return (Lower)	-
23	R41285	1	Adapter, O-ring Seal x 1/2 NPT	-
24	16-01000	1	O-ring 3/4" ID x 3/32"	-
25	R43928	1	Adapter, Turbo Oil Supply	-
26	11-31012	1	Gasket	-
27	12-00714	2	Capscrew, Hex Head M8 x 1.25 x 40 mm	-
28	21-52800	1	Male Connector, Steel 3/8 NPT x 3/8- 37T	-
29	27-09405	1	Tube Assembly, Turbocharger Oil Supply	-
30	21-09502	1	Male Connector, Steel 3/8- 37T x M16 x 1.5	-
31	21-52213	1	Elbow 90° Swivel, Steel 3/8- 37T	-
32	19-72252	1	Adelle Clamp 3/8" ID x 3/8" Stud	-
33	12-00751	1	Capscrew, Hex Head M8 x 1.25 x 16 mm	-
34	15-00702	1	Lock Washer M8	-
35	15-00701	1	Flat Washer M8	-
36	18-21004	1	Hump Hose 4- 1/8" ID x 2" ID x 1- 3/4"	-
37	19-00036	1	Hose Clamp #36	-
38	19-00072	1	Hose Clamp #72	-
39	24-21000	1	Air Filter	-
40	23-21003	1	Bracket, Air Filter Support	-
41	12-00814	2	Capscrew, Hex Head M10 x 1.5 x 35 mm	-
42	15-00802	2	Lock Washer, Helical M10	-
43	15-00805	2	Flat Washer M10	-
44	19-00128	1	Hose Clamp #128	-
45	21-00025	1	Male Elbow 90° PVC 3/4 HB x 3/4 HB	-
46	41-00004	9	Hose 3/4" ID 1 Ply SAE 100R6	-
47	21-00077	1	Female Adapter, Steel 1/8 NPT x M22 x 1.5	-
48	15-09501	1	Sealing Washer Copper M22	-
49	21-10001	1	Drain Cock Brass 1/8 NPT	-
50	27-21002	1	Intake Tube	-
51	16-21001	2	O-ring	-
52	27-21001	2	Intake Elbow	-

Intake and Turbocharger Assembly

M1064T1, M1064T2, M55C2, & M65C2

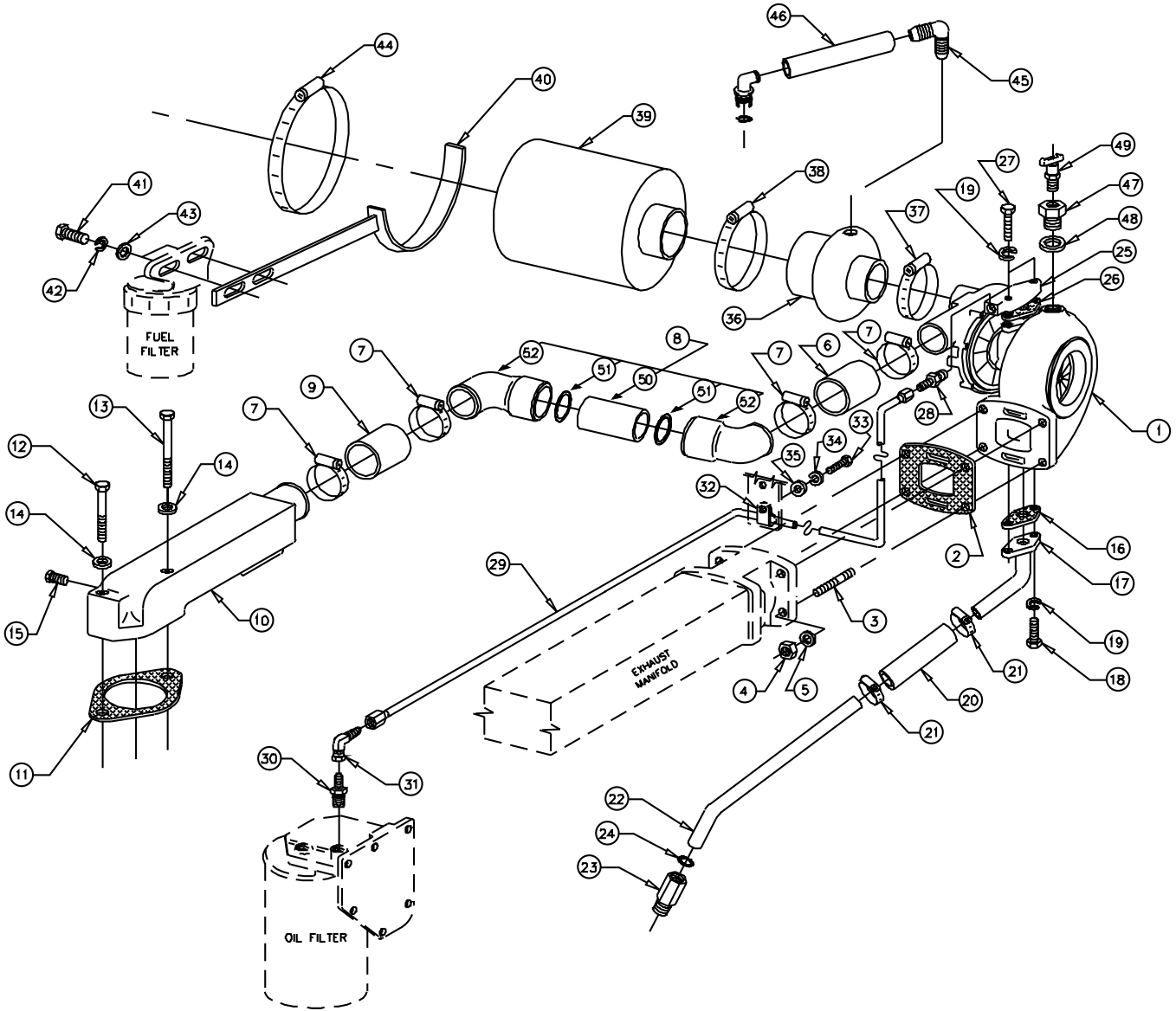

A-10587/ C-4137

Intake and Turbocharger Assembly

M1064T1, M1064T2, M55C2, & M65C2

KEY	PART NUMBER	QTY	DESCRIPTION	SERIAL NUMBER
1	30-21400-1	1	Turbocharger K26 (M1064T1, M55C2, see parts detail)	
	30-39400	1	Turbocharger K26 (M1064T2, M65C2, see parts detail)	-
2	11-31401	1	Gasket	-
3	13-00814	4	Stud, M10 x 1.5 x 30 mm (42 mm LOA)	-
4	14-00817	4	Hex Nut, M10 x 1.5 S/S	-
5	15-00804	4	Wave Washer, M10	-
6	18-21016	1	Hose, 2" ID x 1- 3/4" 3 Ply Silicone	-
7	19-01028	4	Hose Clamp #28 Extended Band S/S	-
8	27-21010	1	Intake Tube Assembly (includes keys #50-52)	-
9	18-21014	1	Hose 2" ID x 2- 3/8" 3 Ply Silicone	-
10	10-21400	1	Intake Manifold	-
11	11-21011	1	Gasket, Intake Port	-
12	12-00071	1	Capscrew, Hex Head M10 x 1.5 x 70 mm	-
13	12-00051	1	Capscrew, Hex Head M10 x 1.5 x 90 mm	-
14	15-00804	2	Wave Washer M10	-
15	21-00012	1	Plug, Hex Head Brass 1/8 NPT	-
16	11-31031	1	Gasket, Turbo Oil Return	-
17	27-31602	1	Pipe, Turbo Oil Return (Upper)	-
18	12-00711	2	Capscrew, Hex Head M8 x 1.25 x 20 mm	-
19	15-00702	4	Lock Washer, Helical M8	-
20	18-11010	1	Hose 3/4" ID x 4-1/4" 3 Ply Silicone	-
21	19-01012	2	Hose Clamp #12 Extended Band S/S	-
22	27-31402	1	Pipe, Turbo Oil Return (Lower)	-
23	R41285	1	Adapter, O-ring Seal x 1/2 NPT	-
24	16-01000	1	O-ring 3/4" ID x 3/32"	-
25	R43928	1	Adapter, Turbo Oil Supply	-
26	11-31012	1	Gasket	-
27	12-00714	2	Capscrew, Hex Head M8 x 1.25 x 40 mm	-
28	21-52800	1	Male Connector, Steel 3/8 NPT x 3/8- 37T	-
29	27-09401	1	Tube Assembly, Turbocharger Oil Supply	-
30	21-09502	1	Male Connector, Steel 3/8- 37T x M16 x 1.5	-
31	21-52213	1	Elbow 90° Swivel, Steel 3/8- 37T	-
32	19-72252	1	Adelle Clamp 3/8" ID x 3/8" Stud	-
33	12-00751	1	Capscrew, Hex Head M8 x 1.25 x 16 mm	-
34	15-00702	1	Lock Washer M8	-
35	15-00701	1	Flat Washer M8	-
36	18-21004	1	Hump Hose 4- 1/8" ID x 2" ID x 1- 3/4"	-
37	19-00036	1	Hose Clamp #36	-
38	19-00072	1	Hose Clamp #72	-
39	24-21000	1	Air Filter	-
40	23-21003	1	Bracket, Air Filter Support	-
41	12-00814	2	Capscrew, Hex Head M10 x 1.5 x 35 mm	-
42	15-00802	2	Lock Washer, Helical M10	-
43	15-00805	2	Flat Washer M10	-
44	19-00128	1	Hose Clamp #128	-
45	21-00025	1	Male Elbow 90° PVC 3/4 HB x 3/4 HB	-
46	41-00004	9	Hose 3/4" ID 1 Ply SAE 100R6	-
47	21-00077	1	Female Adapter, Steel 1/8 NPT x M22 x 1.5	-
48	15-09501	1	Sealing Washer Copper M22	-
49	21-10001	1	Drain Cock Brass 1/8 NPT	-
50	27-21002	1	Intake Tube	-
51	16-21001	2	O-ring	-
52	27-21001	2	Intake Elbow	-

Air Filter and Mounting

L- M1064A

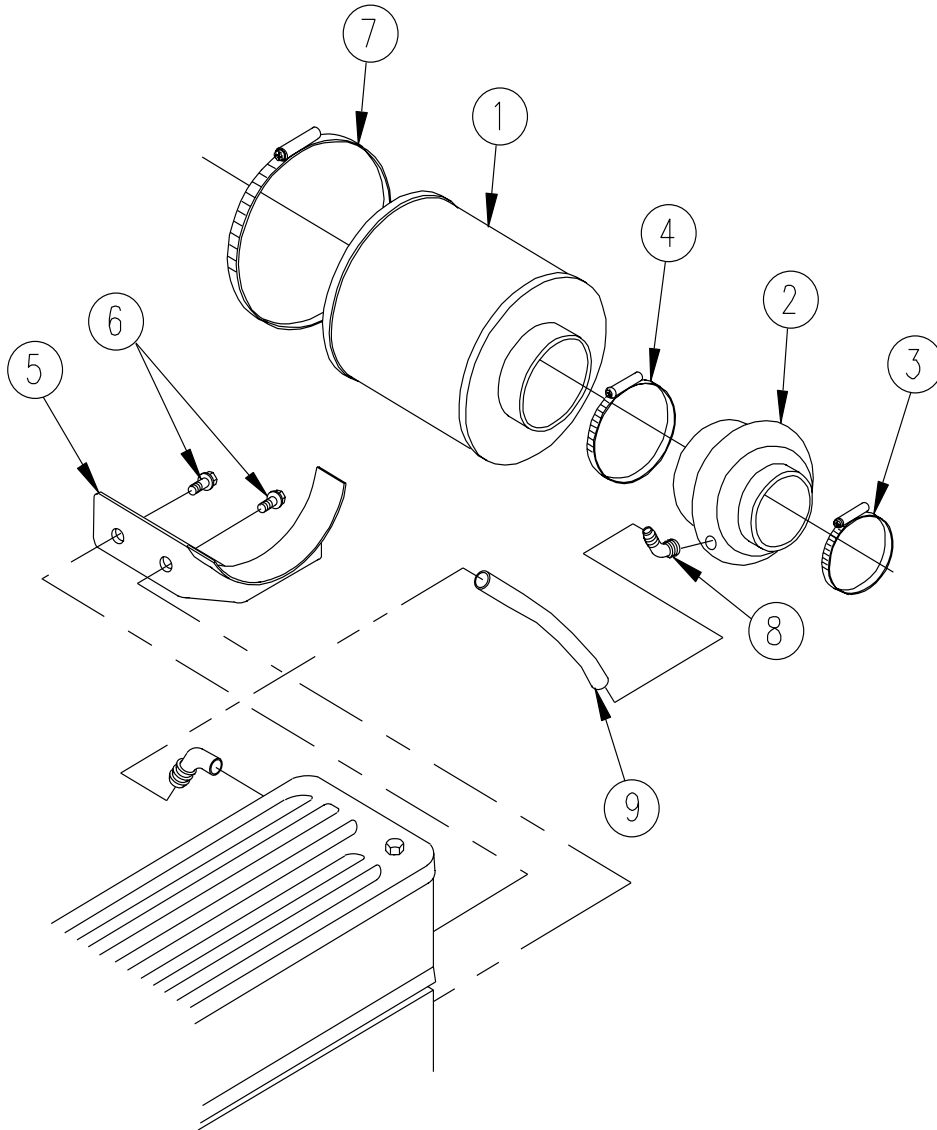

A-10680/ B-8684

KEY	PART NUMBER	QTY	DESCRIPTION	SERIAL NUMBER
1	24-21000	1	Air Filter	-
2	18-29501	1	Hump Hose 4-1/8" I.D. x 2" I.D.	-
3	19-00036	1	Hose Clamp #36	-
4	19-00072	1	Hose Clamp #17	-
5	23-29501	1	Bracket	-
6	19M7785	2	Capscrew, Hex Head Flanged M10 x 1.5 x 25 mm	-
7	19-00128	1	Hose Clamp #128	-
8	21-00025	1	Male Elbow 90° PVC 3/4 HB x 3/4 HB	-
9	41-00004	12	Hose 3/4" ID 1 Ply SAE 100R6	-

Air Filter and Mounting

M1064H

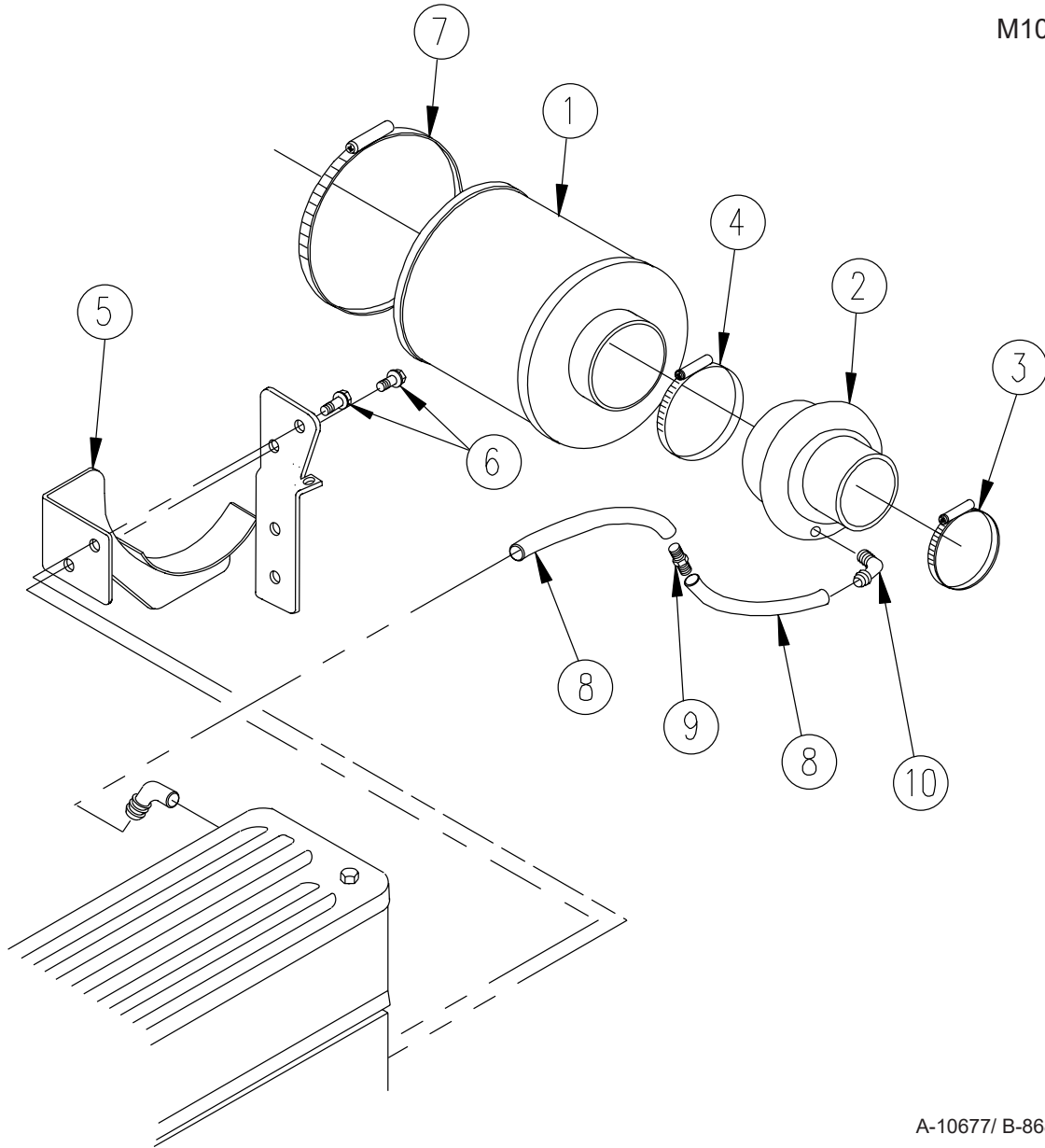

A-10677/ B-8685

KEY	PART NUMBER	QTY	DESCRIPTION	SERIAL NUMBER
1	24-21000	1	Air Filter	-
2	18-29501	1	Hump Hose 4-1/8" I.D. x 2" I.D.	-
3	19-00036	1	Hose Clamp #36	-
4	19-00072	1	Hose Clamp #17	-
5	23-29402	1	Bracket	-
6	19M7786	2	Capscrew, Hex Head Flanged M10 x 1.5 x 30 mm	-
7	19-00128	1	Hose Clamp #128	-
8	145536461	2	Hose	-
9	21-13102	1	Male Union, Brass 3/4 HB	-
10	21-00025	1	Male Elbow, 90° PVC 3/4 HB x 3/4 HB	-

GROUP 2 - INTAKE AND EXHAUST SYSTEMS

Crankcase Breather Filter Assembly

M1064A

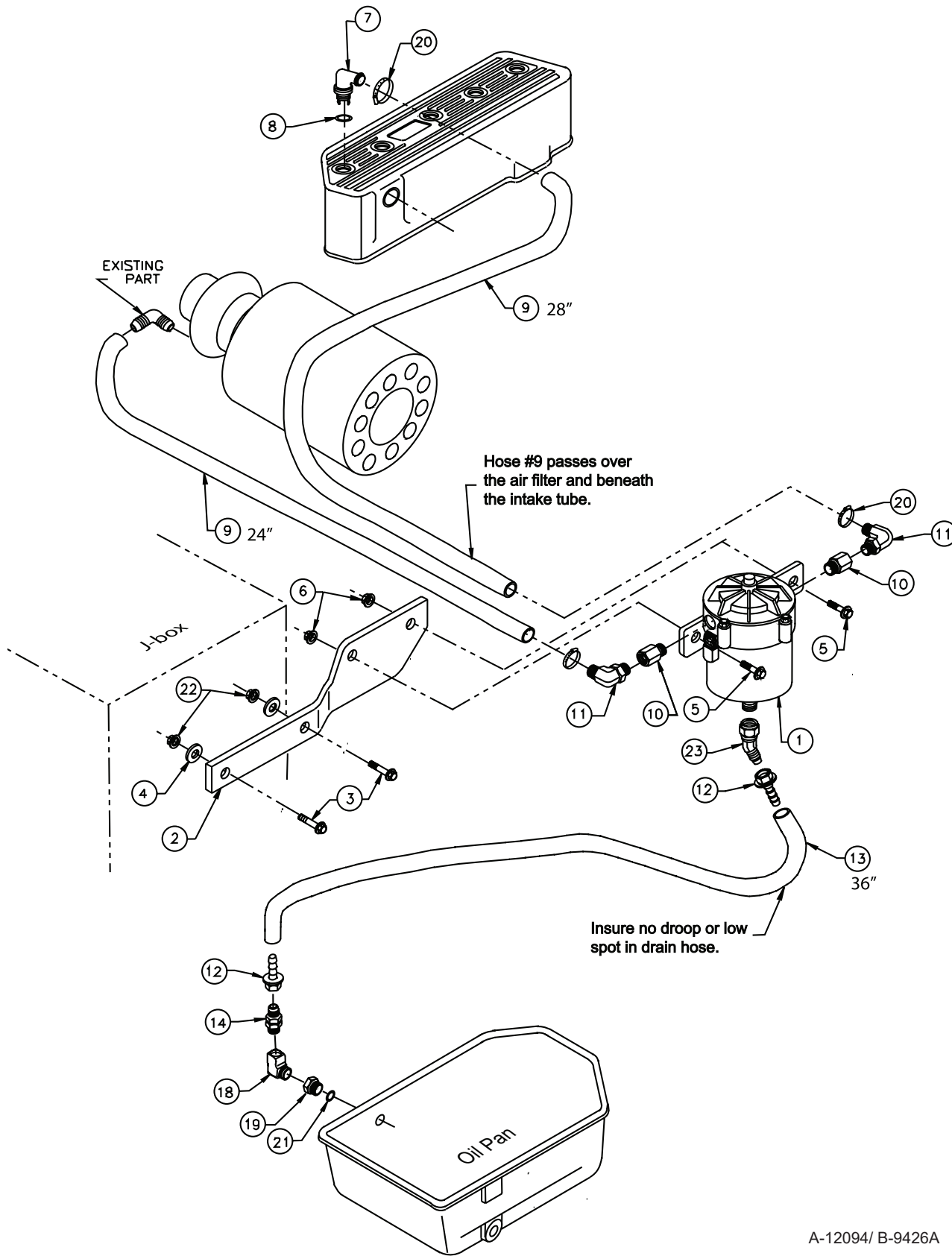

A-12094/ B-9426A

Crankcase Breather Assembly

M1064A

KEY	PART NUMBER	QTY	DESCRIPTION	SERIAL NUMBER
1	24-20018	1	Crankcase Breather Filter	-
2	23-29408	1	Bracket	-
3	19M7785	2	Capscrew, Hex Head Flanged M10 x 1.5 x 25 mm Grade 10.9	-
4	15-70006	2	Snubbing Washer S/S	-
5	12-80832	2	Capscrew, Hex Head Flanged M10 x 1.5 x 30 mm Grade 10.9	-
6	14-80811	2	Hex Nut, Flanged M10 x 1.5	-
7	R120467	1	Elbow, 90° 3/4 HB with o-ring, Vent system connection	-
8	16-01000	1	O-ring 3/4" I.D.	-
9	41-01050	52.5"	Hose 3/4" I.D. Wire reinforced SAE J1527	-
10	21-20007	2	Female Adapter, Steel 3/4 NPT x 7/8 o-ring port	-
11	21-20006	2	Male Elbow, 90° Nylon 3/4 NPT x 3/4 HB	-
12	21-71034	2	Female Swivel, Brass 3/8 HB x 3/8-37T Push-on	-
13	41-01020	36"	Hose 3/8" I.D. Push-on	-
14	21-20002	1	One way Valve, Brass 1/4 NPT x 3/8-37T	-
18	21-51098	1	Street Elbow 90°, Brass 1/4 NPT	-
19	21-79504	1	Female Adapter, Steel 1/4 NPT x M22 x 1.5	-
20	19-00012	2	Hose Clamp #12	-
21	16-09501	1	O-ring	-
22	14-00815	2	Lock Nut, Flanged M10	-
23	21-59519	1	Elbow, 45° Swivel 3/8- 37T	-

GROUP 2 - INTAKE AND EXHAUST SYSTEMS

Crankcase Breather Filter Assembly

M1064H

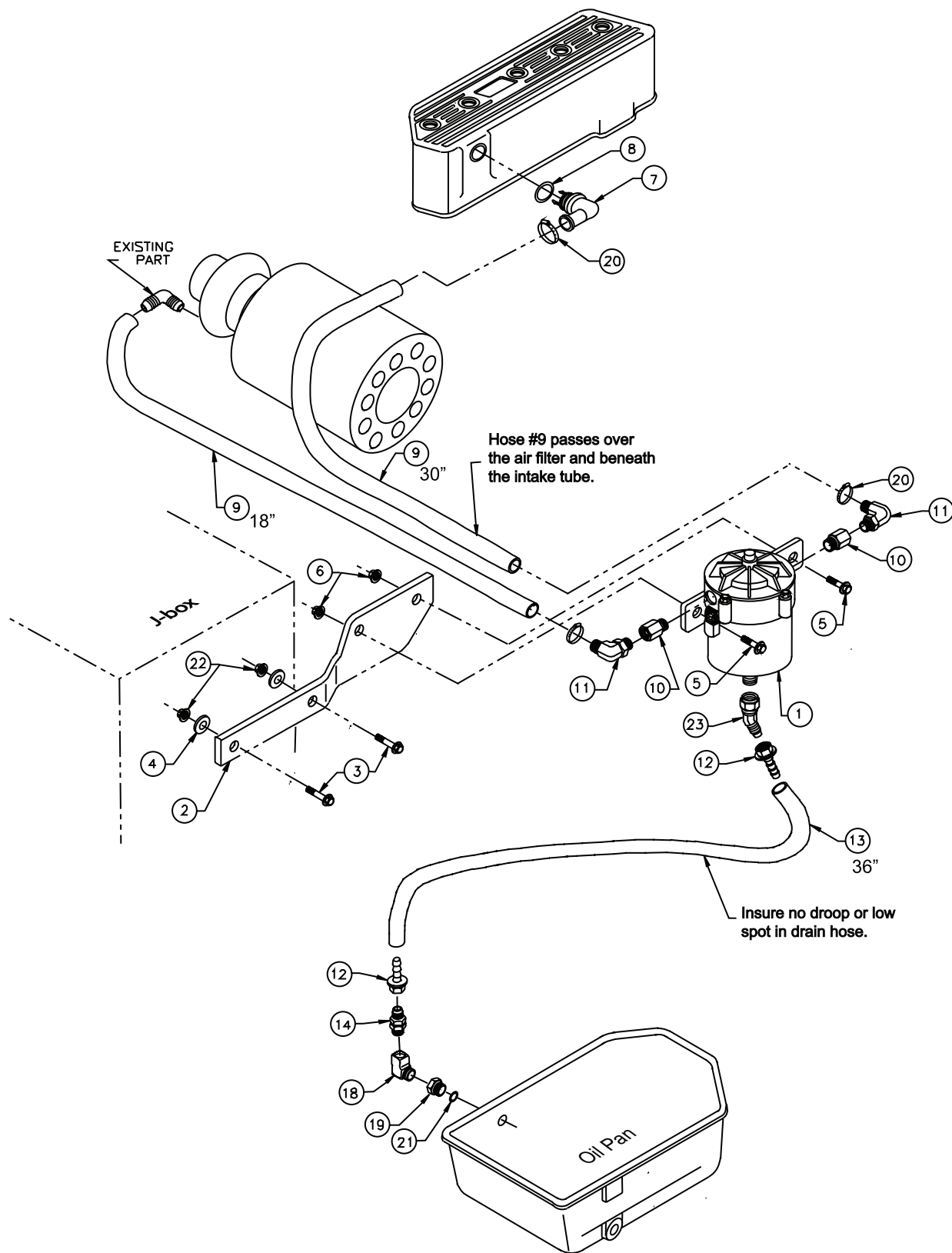

A-12095/ B-9427A

Crankcase Breather Assembly

M1064H

KEY	PART NUMBER	QTY	DESCRIPTION	SERIAL NUMBER
1	24-20018	1	Crankcase Breather Filter	-
2	23-29408	1	Bracket	-
3	19M7785	2	Capscrew, Hex Head Flanged M10 x 1.5 x 25 mm Grade 10.9	-
4	15-70006	2	Flat Washer M10	-
5	12-80832	2	Capscrew, Hex Head Flanged M10 x 1.5 x 30 mm Grade 10.9	-
6	14-80811	2	Hex Nut, Flanged M10 x 1.5	-
7	R120467	1	Elbow, 90° 3/4 HB with o-ring, Vent system connection	-
8	16-01000	1	O-ring 3/4" I.D.	-
9	41-01050	48.5"	Hose 3/4" I.D. Wire reinforced SAE J1527	-
10	21-20007	2	Female Adapter, Steel 3/4 NPT x 7/8 o-ring port	-
11	21-20006	2	Male Elbow, 90° Nylon 3/4 NPT x 3/4 HB	-
12	21-71034	2	Female Swivel, Brass 3/8 HB x 3/8-37T Push-on	-
13	41-01020	36"	Hose 3/8" I.D. Push-on	-
14	21-20002	1	One way Valve, Brass 1/4 NPT x 3/8-37T	-
18	21-51098	1	Street Elbow 90°, Brass 1/4 NPT	-
19	21-79504	1	Female Adapter, Steel 1/4 NPT x M22 x 1.5	-
20	19-00012	2	Hose Clamp #12	-
21	16-09501	1	O-ring	-
22	14-00815	2	Lock Nut, Flanged M10	-
23	21-59519	1	Elbow, 45° Swivel 3/8- 37T	-

Intake and Aftercooler Assembly

L- M1064A

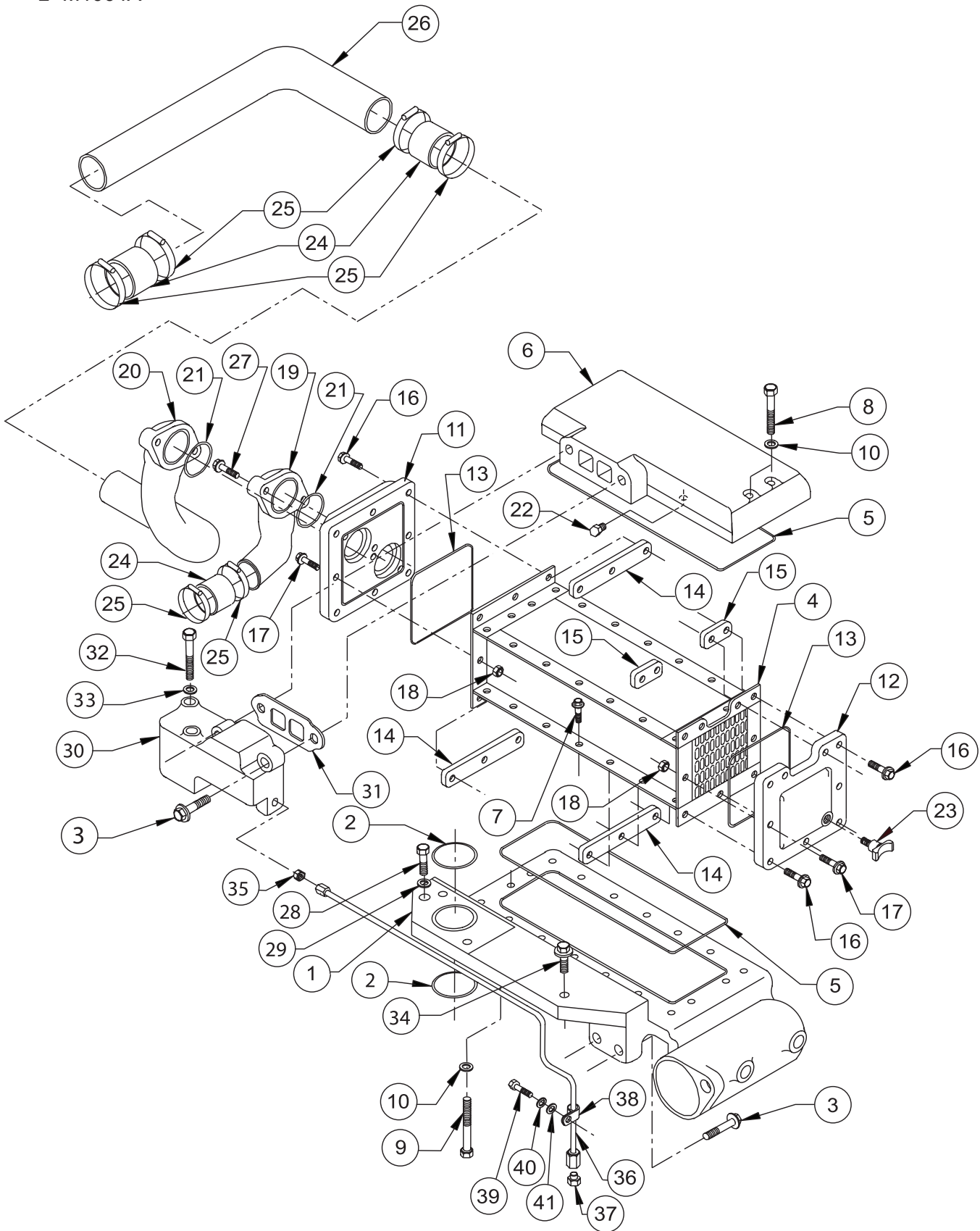

A-10284/ C-5600

Intake and Aftercooler Assembly

L- M1064A

KEY	PART NUMBER	QTY	DESCRIPTION	SERIAL NUMBER
1	10-29404	1	Manifold, Intake & Aftercooler	-
2	16-29502	2	O-ring	-
3	12-80832	4	Capscrew, Hex Head Flanged M10 x 1.5 x 30 mm	-
4	20-29401	1	Element, Intake Aftercooler	-
5	16-09401	2	O-ring	-
6	10-29403	1	Aftercooler Cover	-
7	19M7865	28	Capscrew, Hex Head Flanged M8 x 1.25 x 16 mm (Grade 10)	-
8	12-00733	2	Capscrew, Hex Head M8 x 1.25 x 180 mm (Grade 8.8)	-
9	12-00733	2	Capscrew, Hex Head M8 x 1.25 x 180 mm (Grade 8.8)	-
10	15-00706	4	Flat Washer M8 S/S	-
11	10-29503	1	Aftercooler Cover	-
12	10-29502	1	Aftercooler Cover	-
13	16-09504	2	O-ring	-
14	28-09501	3	Plate, Threaded (3 Places)	-
15	28-09502	2	Plate, Threaded (2 Places)	-
16	19M7866	13	Capscrew, Hex Head Flanged M8 x 1.25 x 20 mm (Grade 10)	-
17	19M7867	4	Capscrew, Hex Head Flanged M8 x 1.25 x 25 mm (Grade 10)	-
18	14M7298	4	Hex Nut, Flanged M8 x 1.25	-
19	27-09503	1	Connector, Raw Water Pump Outlet	-
20	27-09504	1	Connector, Aftercooler Outlet	-
21	16-13101	2	O-ring	-
22	21-00027	1	Plug, Socket Head Brass, 1/8 NPT	-
23	21-10002	1	Drain Cock Brass 1/4 NPT	-
24	18-26002	3	Hose 2" ID x 3 -3/4" 3 Ply Silicone	-
25	19-01032	6	Hose Clamp #32 Extended Band	-
26	27-19514	1	Tube, Heat Exchanger Inlet	-
27	19M8320	4	Capscrew, Hex Head Flanged M10 x 1.5 x 45 mm (Grade 10)	-
28	12-00954	1	Capscrew, Hex Head M12 x 1.75 x 35 mm	-
29	15-00904	1	Wave Washer M12	-
30	21-29504	1	Connector, Aftercooler Intake	-
31	11-29501	1	Gasket, Aftercooler Mounting	-
32	12-00842	2	Capscrew, Hex Head M10 x 1.5 x 140 mm	-
33	15-00804	2	Wave Washer M10	-
34	01435-01035	1	Capscrew, Hex Head Flanged M10 x 1.5 x 35 mm	-
35	21-09516	1	Male Connector, S/S 3/8- 37T x 3/8 OR Port	-
36	27-29404	1	Tube Assembly, Aftercooler Condensate Drain	-
37	21-29504	1	Drain, Aftercooler Condensate	-
38	19-72252	1	Adelle Clamp, 3/8" I.D. x 3/8" Stud	-
39	12-00776	1	Capscrew, Hex Head M8 x 1.25 x 20 mm S/S	-
40	15-00705	1	Lock Washer, Helical M8 S/S	-
41	15-00706	1	Flat Washer, M8 S/S	-

Intake and Turbocharger Assembly

L1064A

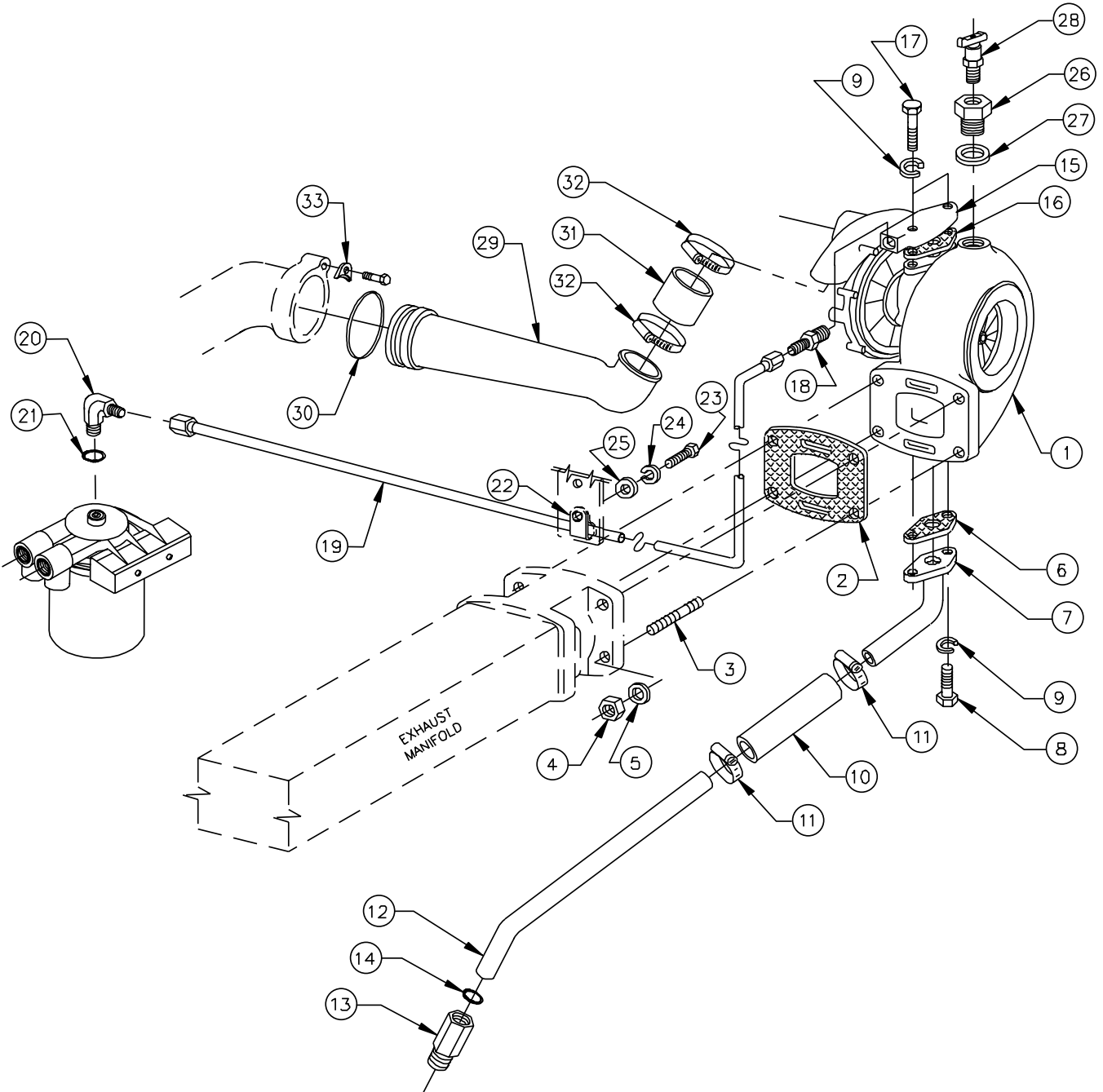

A-11068/ C-5550z

Intake and Turbocharger Assembly

L1064A

KEY	PART NUMBER	QTY	DESCRIPTION	SERIAL NUMBER
1	30-39400	1	Turbocharger K26, L1064A (see parts detail)	-
2	11-31401	1	Gasket	-
3	13-00814	4	Stud, M10 x 1.5 x 30 mm (42 mm LOA)	-
4	14-00817	4	Hex Nut, M10 x 1.5 S/S	-
5	15-00804	4	Wave Washer, M10	-
6	11-31031	1	Gasket, Turbo Oil Return	-
7	27-31602	1	Tube, Turbo Oil Return	-
8	12-00711	2	Capscrew, Hex Head M8 x 1.25 x 20 mm	-
9	15-00702	4	Lock Washer, M8	-
10	18-11010	1	Hose, 3/4" I.D. x 4-1/4"	-
11	19-01012	2	Hose Clamp #12	-
12	27-31402	1	Pipe, Turbo Oil Return (Lower)	-
13	R41285	1	Adapter, O-ring Seal x 1/2 NPT	-
14	16-01000	1	O-ring	-
15	R43928	1	Adapter, Turbo Oil Supply	-
16	11-31012	1	Gasket	-
17	12-00714	2	Capscrew, Hex Head M8 x 1.25 x 40 mm	-
18	21-52800	1	Male Connector, Steel 3/8 NPT x 3/8- 37T	-
19	27-09403	1	Tube Assembly, Turbo Oil Supply	-
20	21-09501	1	Male Elbow, 90° Steel 3/8- 37T x M16 x 1.5	-
21	51M7042	1	O-ring	-
22	19-72252	1	Adelle Clamp 3/8" I.D. x 3/8" Stud	-
23	12-00751	1	Capscrew, Hex Head M8 x 1.25 x 16 mm	-
24	15-00702	1	Lock Washer, Helical M8	-
25	15-00701	1	Flat Washer M8	-
26	21-00077	1	Female Adapter, Steel 1/8 NPT x M22 x 1.5	-
27	15-09501	1	Sealing Washer, Copper M22	-
28	21-10001	1	Drain Cock, Brass 1/8 NPT	-
29	27-29402	1	Tube, Air Inlet K26	-
30	16-25701	1	O-ring 2- 7/8" I.D.	-
31	18-21014	1	Hose, 2" I.D. x 2- 3/8"	-
32	19-01028	2	Hose Clamp #28 Extended Band S/S	-
33	00-29501	1	Elbow Retaining Clip	-
34	12-00711	1	Capscrew, Hex Head M8 x 1.25 x 20 mm	-
35	15-00707	1	Wave Washer M8	-

Intake and Turbocharger Assembly

M1064A

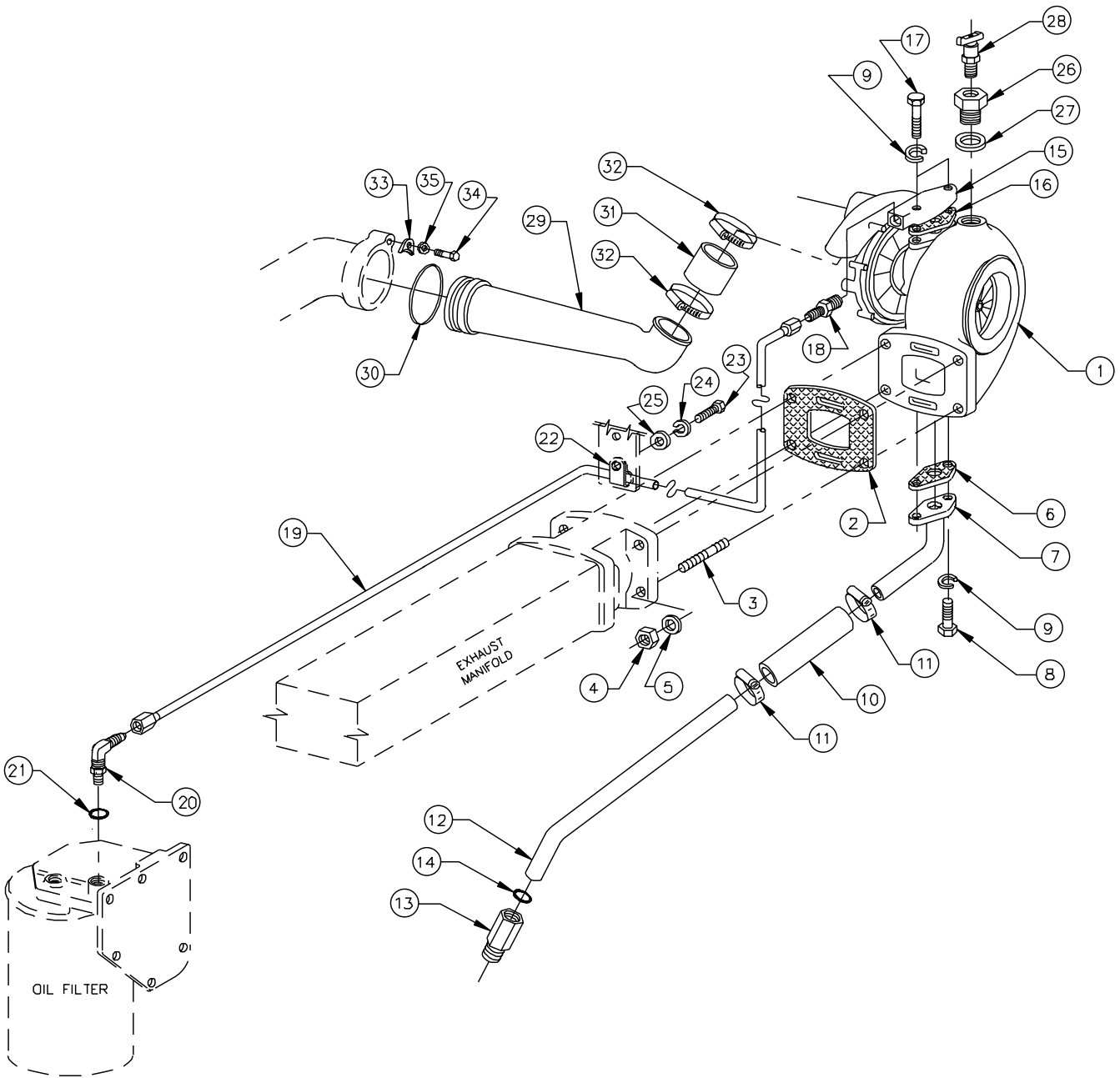

A-10823, A-10423/ C-5550

Intake and Turbocharger Assembly

M1064A

KEY	PART NUMBER	QTY	DESCRIPTION	SERIAL NUMBER
1	30-31426-1	1	Turbocharger K26, M1064A @1800 RPM (see parts detail)	-
	30-39400	1	Turbocharger K26, M1064A @1500 RPM (see parts detail)	-
2	11-31401	1	Gasket	-
3	13-00814	4	Stud, M10 x 1.5 x 30 mm (42 mm LOA)	-
4	14-00817	4	Hex Nut, M10 x 1.5 S/S	-
5	15-00804	4	Wave Washer, M10	-
6	11-31031	1	Gasket, Turbo Oil Return	-
7	27-31602	1	Tube, Turbo Oil Return	-
8	12-00711	2	Capscrew, Hex Head M8 x 1.25 x 20 mm	-
9	15-00702	4	Lock Washer, M8	-
10	18-11010	1	Hose, 3/4" I.D. x 4-1/4"	-
11	19-01012	2	Hose Clamp #12	-
12	27-31402	1	Pipe, Turbo Oil Return (Lower)	-
13	R41285	1	Adapter, O-ring Seal x 1/2 NPT	-
14	16-01000	1	O-ring	-
15	R43928	1	Adapter, Turbo Oil Supply	-
16	11-31012	1	Gasket	-
17	12-00714	2	Capscrew, Hex Head M8 x 1.25 x 40 mm	-
18	21-52800	1	Male Connector, Steel 3/8 NPT x 3/8- 37T	-
19	27-09401	1	Tube Assembly, Turbo Oil Supply	-
20	21-09501	1	Male Elbow, 90° Steel 3/8- 37T x M16 x 1.5 (includes key 21)	-
21	51M7042	1	O-ring	-
22	19-72252	1	Adelle Clamp 3/8" I.D. x 3/8" Stud	-
23	12-00751	1	Capscrew, Hex Head M8 x 1.25 x 16 mm	-
24	15-00702	1	Lock Washer, Helical M8	-
25	15-00701	1	Flat Washer M8	-
26	21-00077	1	Female Adapter, Steel 1/8 NPT x M22 x 1.5	-
27	15-09501	1	Sealing Washer, Copper M22	-
28	21-10001	1	Drain Cock, Brass 1/8 NPT	-
29	27-29402	1	Tube, Air Inlet K26	-
30	16-25701	1	O-ring 2- 7/8" I.D.	-
31	18-21014	1	Hose, 2" I.D. x 2- 3/8"	-
32	19-01028	2	Hose Clamp #28 Extended Band S/S	-
33	00-29501	1	Elbow Retaining Clip	-
34	12-00711	1	Capscrew, Hex Head M8 x 1.25 x 20 mm	-
35	15-00707	1	Wave Washer M8	-

Intake and Aftercooler Assembly

M1064H

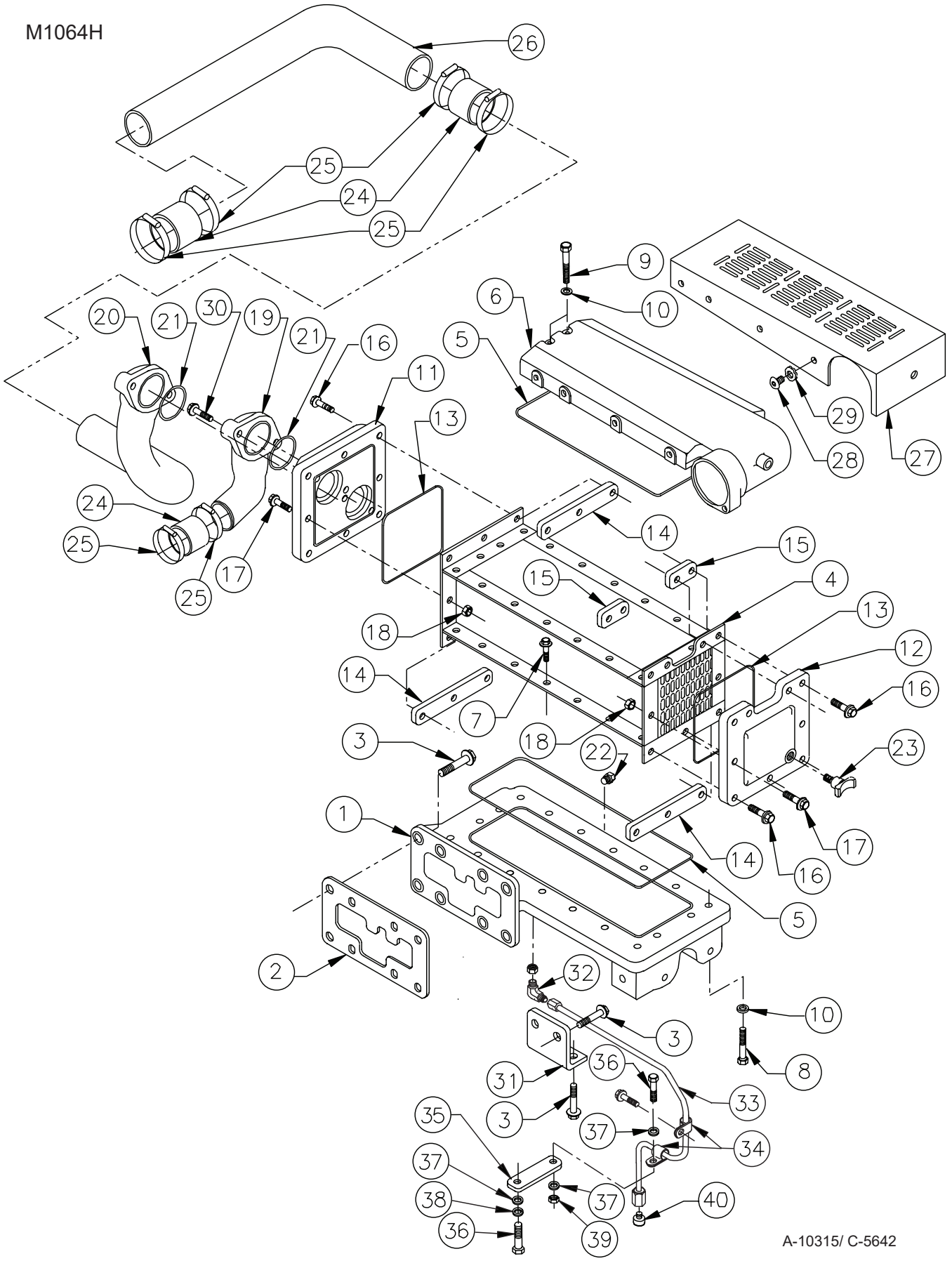

A-10315/ C-5642

Intake and Aftercooler Assembly

M1064H

KEY	PART NUMBER	QTY	DESCRIPTION	SERIAL NUMBER
1	10-29401	1	Manifold, Intake & Aftercooler	-
2	R502916	1	Gasket, Intake Manifold	-
3	19M7785	12	Capscrew, Hex Head Flanged M10 x 1.5 x 25 mm	-
4	20-29401	1	Element, Intake Aftercooler	-
5	16-09401	2	O-ring	-
6	10-29402	1	Aftercooler Cover	-
7	19M7865	28	Capscrew, Hex Head Flanged M8 x 1.25 x 16 mm (Grade 10)	-
8	12-00732	2	Capscrew, Hex Head M8 x 1.25 x 160 mm (Grade 8.8)	-
9	12-00733	2	Capscrew, Hex Head M8 x 1.25 x 180 mm (Grade 8.8)	-
10	15-00706	4	Flat Washer M8 S/S	-
11	10-29503	1	Aftercooler Cover	-
12	10-29502	1	Aftercooler Cover	-
13	16-09504	2	O-ring	-
14	28-09501	3	Plate, Threaded (3 Places)	-
15	28-09502	2	Plate, Threaded (2 Places)	-
16	19M7866	13	Capscrew, Hex Head Flanged M8 x 1.25 x 20 mm (Grade 10)	-
17	19M7867	4	Capscrew, Hex Head Flanged M8 x 1.25 x 25 mm (Grade 10)	-
18	14M7298	4	Hex Nut, Flanged M8 x 1.25	-
19	27-09501	1	Connector, Raw Water Pump Outlet	-
20	27-09502	1	Connector, Aftercooler Outlet	-
21	16-13101	2	O-ring	-
22	21-00027	1	Plug, Socket Head Brass, 1/8 NPT	-
23	21-31624	1	Plug, Hex Head Brass 1/4 NPT	-
24	18-26002	3	Hose 2" ID x 3-3/4" 3 Ply Silicone	-
25	19-01032	6	Hose Clamp #32 Extended Band	-
26	27-19510	1	Tube, Heat Exchanger Inlet	-
27	00-29401	1	Heat Shield, Aftercooler	-
28	12-99757	9	Capscrew, Button Head Socket M8 x 1.25 x 16 mm S/S	-
29	15-99707	9	Wave Washer M8 S/S	-
30	19M8320	4	Capscrew, Hex Head Flanged M10 x 1.5 x 45 mm	-
31	23-29401	1	Bracket, Intake Manifold Support	-
32	21-09511	1	Male Elbow 90° S/S, 3/8 O-ring Port	-
33	27-29403	1	Tube Assembly, Aftercooler Condensate	-
34	19-72252	2	Adelle Clamp 3/8" I.D. x 3/8" Stud	-
35	23-25004	1	Bracket, Tube Support	-
36	12-09712	2	Capscrew, Hex Head M8 x 1.25 x 25 mm S/S	-
37	15-00706	3	Flat Washer M8 S/S	-
38	15-00705	1	Lock Washer, Helical M8 S/S	-
39	14-09712	1	Hex Nut, Nylock M8 x 1.25 S/S	-
40	21-29504	1	Drain, Aftercooler Condensate	-

GROUP 2 - INTAKE AND EXHAUST SYSTEMS

Intake and Turbocharger Assembly

M1064H Radiator Cooled

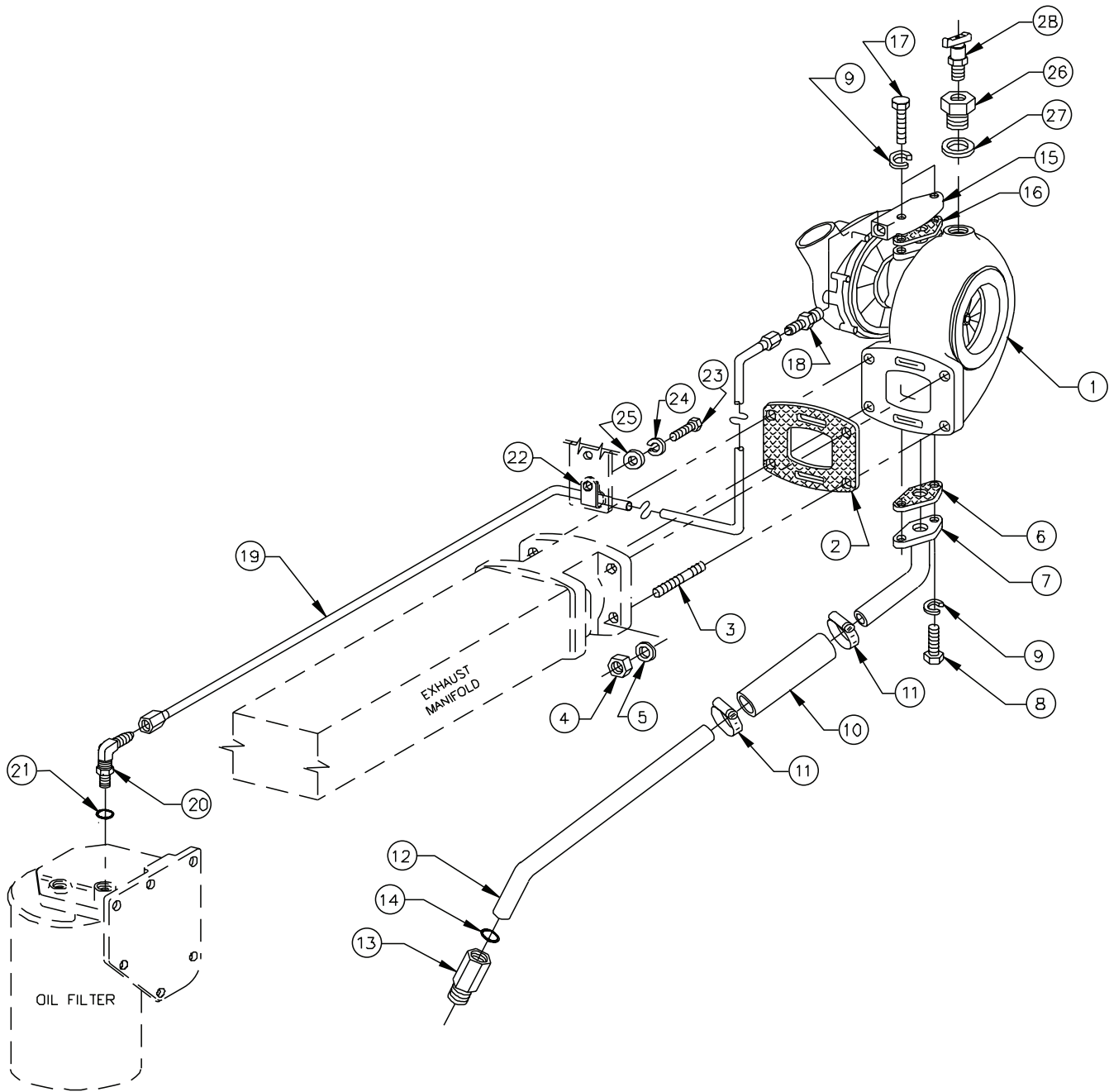

A-10325/ C-5649

Intake and Turbocharger Assembly

M1064H Radiator Cooled

KEY	PART NUMBER	QTY	DESCRIPTION	SERIAL NUMBER
1	30-39400	1	Turbocharger K26	-
2	11-31401	1	Gasket	-
3	13-00814	4	Stud, M10 x 1.5 x 30 mm (42 mm LOA)	-
4	14-00817	4	Hex Nut, M10 x 1.5 S/S	-
5	15-00804	4	Wave Washer, M10	-
6	11-31031	1	Gasket, Turbo Oil Return	-
7	27-31602	1	Tube, Turbo Oil Return (Upper)	-
8	12-00711	2	Capscrew, Hex Head M8 x 1.25 x 20 mm	-
9	15-00702	4	Lock Washer, M8	-
10	18-11010	1	Hose, 3/4" I.D. x 4-1/4"	-
11	19-01012	2	Hose Clamp #12	-
12	27-39504	1	Pipe, Turbo Oil Return (Lower)	-
13	R41285	1	Adapter, O-ring Seal x 1/2 NPT	-
14	16-01000	1	O-ring	-
15	R43928	1	Adapter, Turbo Oil Supply	-
16	11-31012	1	Gasket	-
17	12-00714	2	Capscrew, Hex Head M8 x 1.25 x 40 mm	-
18	21-52800	1	Male Connector, Steel 3/8 NPT x 3/8- 37T	-
19	27-09401	1	Tube Assembly, Turbo Oil Supply	-
20	21-09501	1	Male Elbow, 90° Steel 3/8- 37T x M16 x 1.5 (includes key 21)	-
21	51M7042	1	O-ring	-
22	19-72252	1	Adelle Clamp 3/8" I.D. x 3/8" Stud	-
23	12-00751	1	Capscrew, Hex Head M8 x 1.25 x 16 mm	-
24	15-00702	1	Lock Washer, Helical M8	-
25	15-00701	1	Flat Washer M8	-
26	21-00077	1	Female Adapter, Steel 1/8 NPT x M22 x 1.5	-
27	15-09501	1	Sealing Washer, Copper M22	-
28	21-10001	1	Drain Cock, Brass 1/8 NPT	-

Intake and Filter M40C2

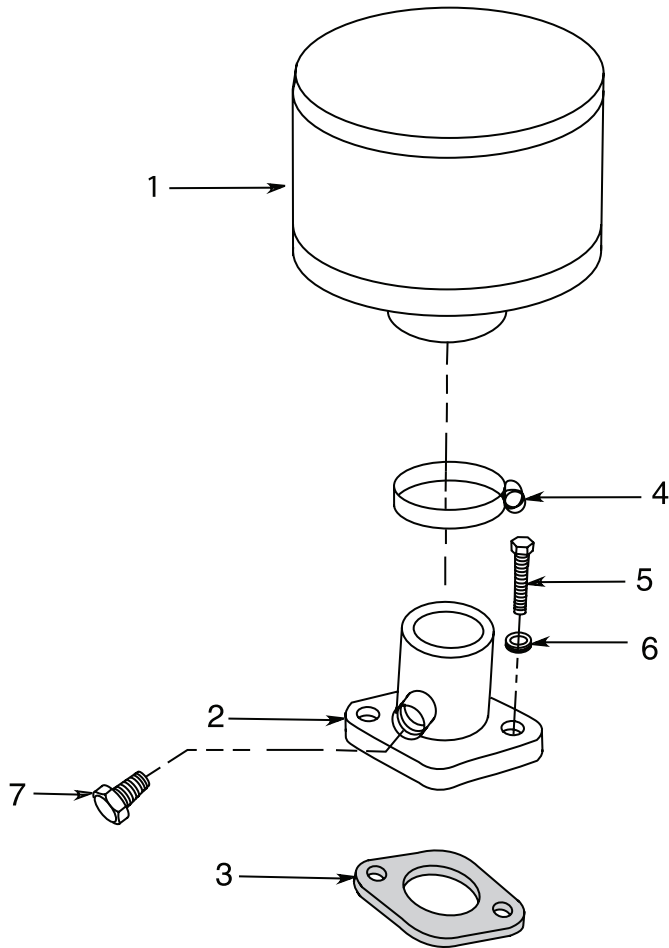

Intake Filter

KEY	PART NUMBER	QTY	DESCRIPTION	SERIAL NUMBER
1	24-20001	1	Air Filter	-
2	10-29501	1	Air Inlet	-
3	11-21011	1	Gasket	-
4	19-00044	1	Hose Clamp #44	-
5	12-00831	2	Capscrew, Hex Head, M10 x 1.5 x 25 mm	-
6	15-00804	2	Wave Washer, M10	-
7	21-00530	1	Plug, Hex Head Brass 1/2 NPT	-

Intake and Filter NL1064D

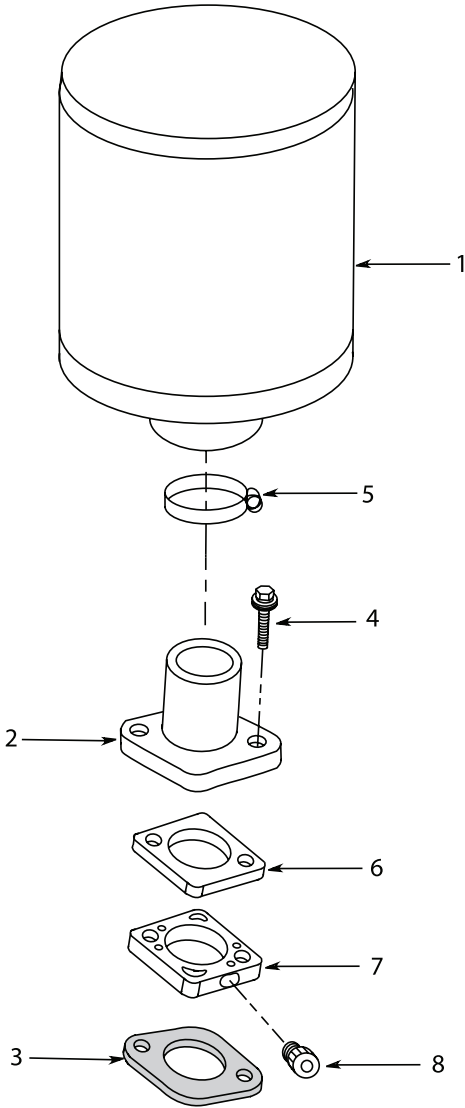

Intake Filter

KEY	PART NUMBER	QTY	DESCRIPTION	SERIAL NUMBER
1	24-21406	1	Air Filter	-
2	R501480	1	Air Inlet	-
3	11-21011	1	Gasket	-
4	19M8292	2	Capscrew, Hex Head Flanged, M10 x 1.5 x 25	-
5	19-00044	1	Hose Clamp #44	-
6	R133893	1	Gasket	-
7	R501472	1	Spacer, Air Inlet	-
8	RE60071	1	Plug (includes key #8)	-
9	51M7039	1	O-ring (not shown)	-

Crankcase Breather Assembly

NL1064D, T, and M40C2

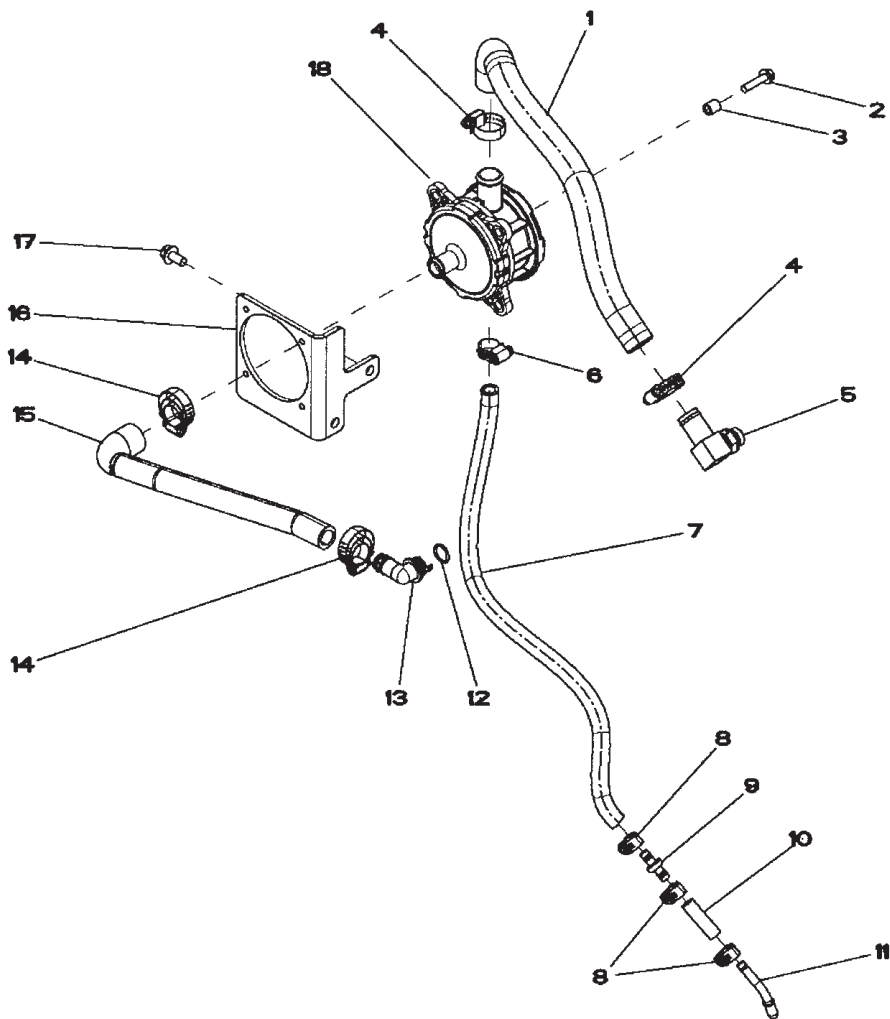

Crankcase Breather Assembly

NL1064D, T, and M40C2

KEY	PART NUMBER	QTY	DESCRIPTION	SERIAL NUMBER
1	R519368	1	Hose	-
2	19M8291	4	Capscrew, M8 x 35 mm	-
3	28H3376	4	Spacer	-
4	AR21839	2	Clamp	-
5	AT196258	1	Elbow Fitting, 5/8 O-ring Port x 1" Hose Barb	-
6	RE65978	1	Clamp	-
7	41-01032	21"	Hose	-
8	AR21836	3	Clamp	-
9	RE522079	1	Check Valve	-
10	41-01020	5"	Hose	-
11	R519401	1	Tube	-
12	R72328	1	O-ring	-
13	R120467	1	Elbow Fitting	-
14	AR21839	2	Clamp	-
15	R519367	1	Hose	-
16	R519400	2	Bracket	-
17	19M7785	1	Capscrew, M10 x 25 mm	-
18	RE522766	1	Crankcase Breather	-
19	R519465	1	Hose Barb Reducer (not shown)	-

GROUP 2 - INTAKE AND EXHAUST SYSTEMS

Intake Manifold NL1064D

With Severe Service Air Filter

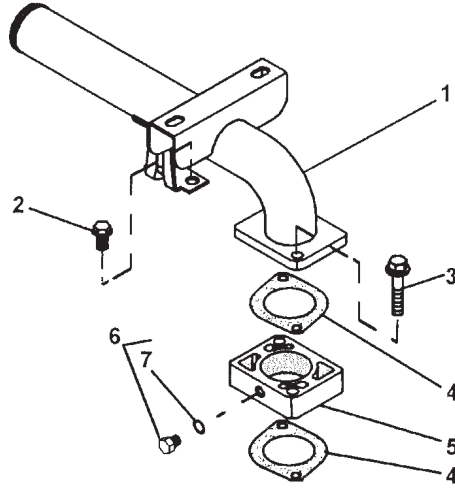

RGP9821

Reproduced by permission of Deere & Co., c2005. Deere & Company. All rights reserved.

KEY	PART NUMBER	QTY	DESCRIPTION	SERIAL NUMBER
1	RE502493	1	Intake Manifold	-
2	19M7784	1	Capscrew, M10 x 20 mm	-
3	19M8292	2	Capscrew, M10 x 50 mm	-
4	R81275	2	Gasket	-
5	R501472	1	Spacer	-
6	RE60071	1	Fitting	-
7	51M7039	1	O-ring	-

Intake Manifold NL1064T1

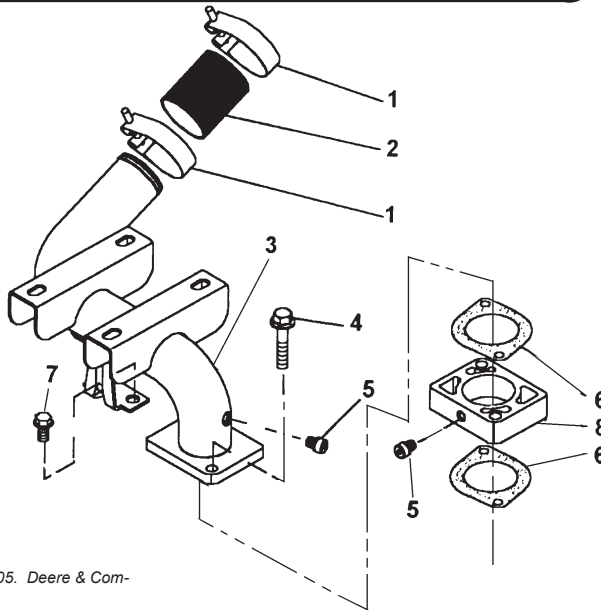

Reproduced by permission of Deere & Co., c2005. Deere & Company. All rights reserved.

RGP9638

KEY	PART NUMBER	QTY	DESCRIPTION	SERIAL NUMBER
1	R110531	2	Clamp	-
2	R500596	1	Hose	-
3	RE508936	1	Air Intake	-
4	19M8292	2	Screw, M10 x 50 mm	-
5	RE60071	2	Fitting	-
6	R81275	2	Gasket	-
7	19M7784	1	Screw, M10 x 20 mm	-
8	R501472	1	Spacer	-

Intake Manifold NL1064T2

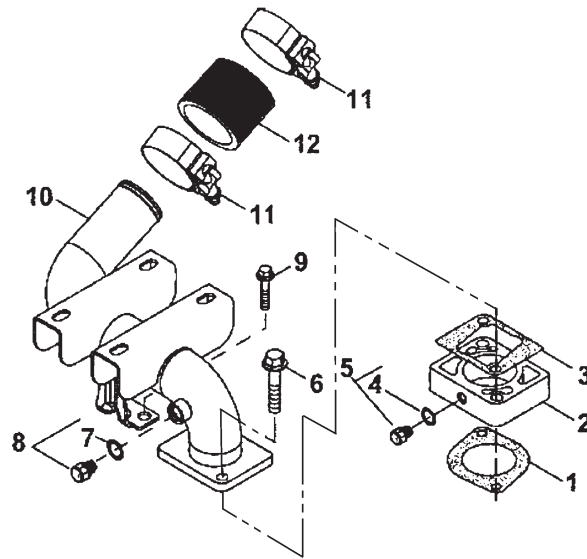

Reproduced by permission of Deere & Co., c2005. Deere & Company. All rights reserved.

RGP8450

KEY	PART NUMBER	QTY	DESCRIPTION	SERIAL NUMBER
1	R81275	1	Gasket	-
2	R501472	1	Spacer	-
3	R133893	1	Gasket	-
4	51M7039	1	O-ring	-
5	RE60071	1	Fitting	-
6	19M8292	2	Screw	-
7	51M7041	1	O-ring	-
8	RE46684	1	Plug	-
9	19M7784	2	Screw	-
10	RE515582	1	Intake Manifold	-
11	R110531	2	Clamp	-
12	R500596	1	Hose	-

Intake Manifold NL1064H1

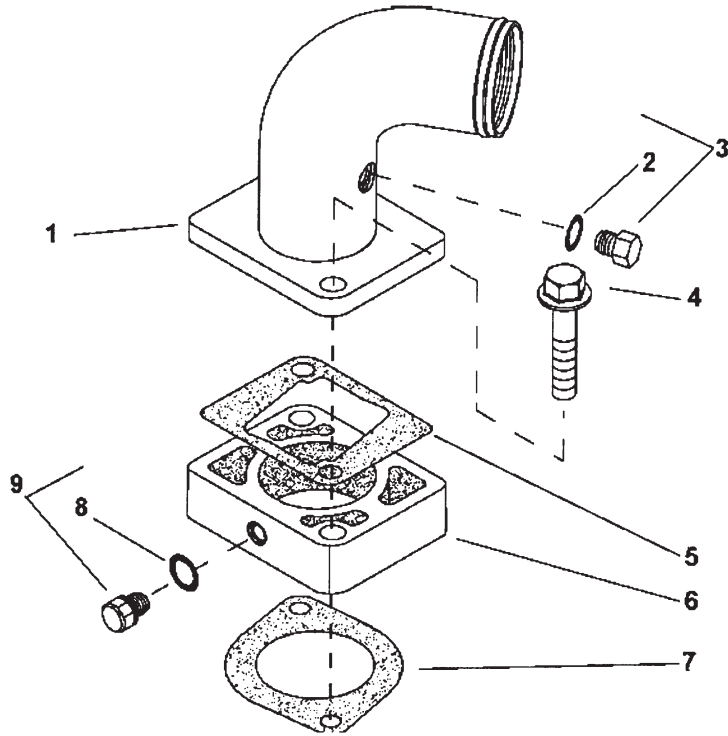

Reproduced by permission of Deere & Co., c2005. Deere & Company. All rights reserved.

RGP8199

KEY	PART NUMBER	QTY	DESCRIPTION	SERIAL NUMBER
1	RE508762	1	Air Intake	-
2	51M7041	2	O-ring	-
3	RE46684	2	Plug (includes key 2)	-
4	19M8292	2	Screw, M10 x 50	-
5	R133893	1	Gasket	-
6	R501472	1	Spacer	-
7	R81275	1	Gasket	-
8	51M7039	1	O-ring	-
9	RE60071	1	Fitting (includes key 8)	-

Intake Manifold NL1064H2

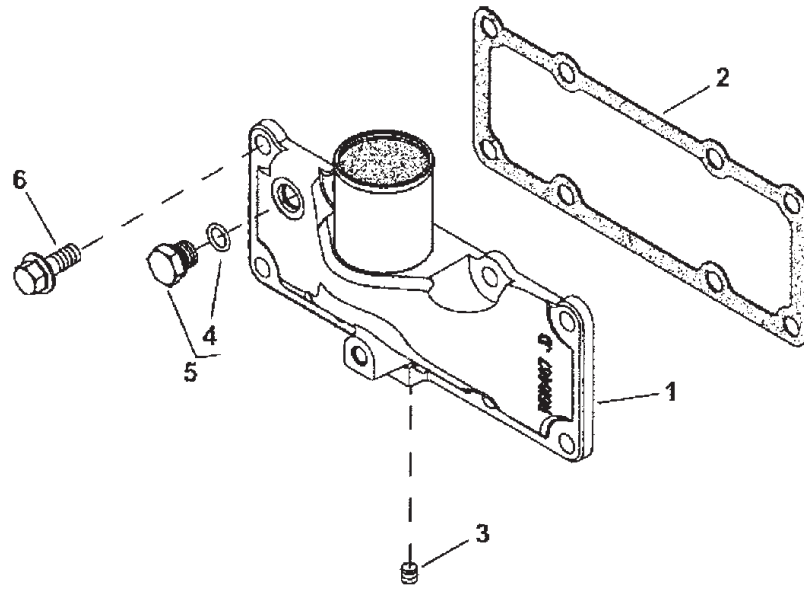

Reproduced by permission of Deere & Co., c2005. Deere & Company. All rights reserved.

RE517071SPA

KEY	PART NUMBER	QTY	DESCRIPTION	SERIAL NUMBER
1	RE517330	1	Intake Manifold	-
2	R502916	1	Gasket	-
3	R104592	1	Pipe Plug	-
4	51M7041	1	O-ring	-
5	RE46684	1	Plug	-
6	19M7785	8	Screw	-

Air Filter Assembly, Severe Service

NL1064D

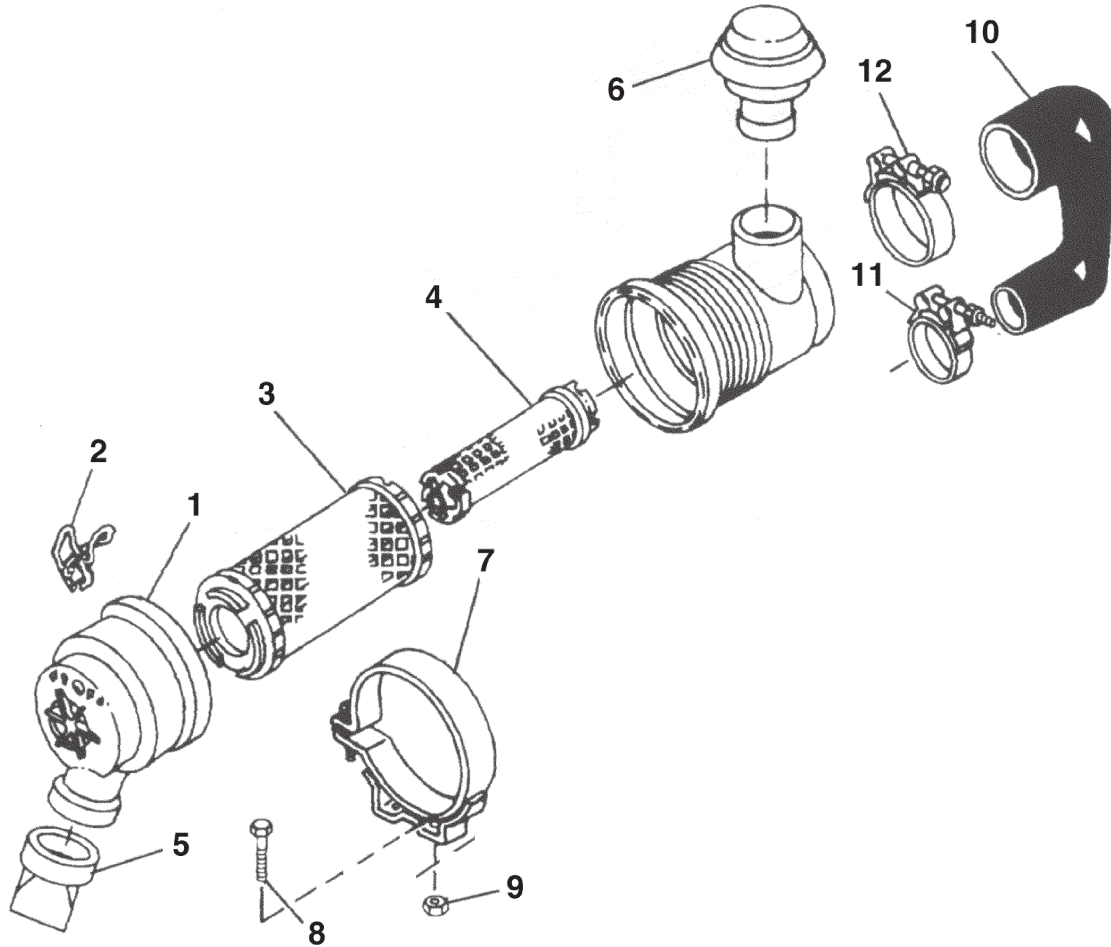

Reproduced by permission of Deere & Co., c2005. Deere & Company. All rights reserved.

RG6292z

KEY	PART NUMBER	QTY	DESCRIPTION	SERIAL NUMBER
••	RE64098	1	Air Cleaner	-
1	AT171855	1	Cover	-
2	AT180680	3	Latch	-
3	AT171853	1	Air Filter, Outer	-
4	AT171854	1	Air Filter, Inner	-
5	R48568	1	Valve	-
6	RE64099	1	Rain Cap (Standard)	-
	24-21407	1	Air Pre-cleaner (optional)	-
7	RE64100	1	Band	-
8	19M7784	4	Capscrew, M10 x 20 mm	-
9	14M7296	4	Flange Nut M10	-
10	R132731	1	Suction Hose	-
11	AT56658	1	Hose Clamp	-
12	R110531	1	Clamp	-

Air Filter Assembly

NL1064T1, T2

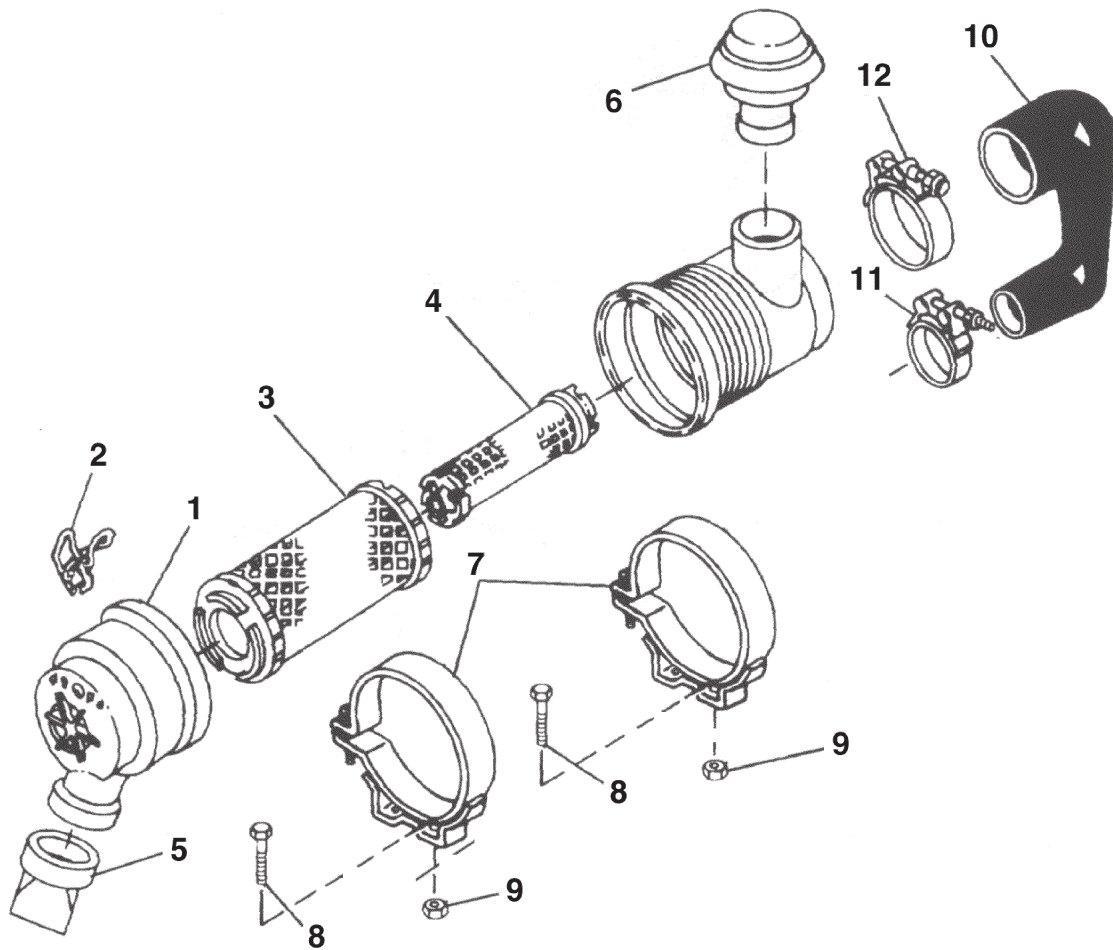

Reproduced by permission of Deere & Co., c2005. Deere & Company. All rights reserved.

RGP6292

KEY	PART NUMBER	QTY	DESCRIPTION	SERIAL NUMBER
••	AT203471	1	Air Filter Assembly (includes keys #1-5)	-
1	RE501727	1	Cover	-
2	R122386	1	Clip	-
3	AT203469	1	Outer Element	-
4	AT203470	1	Inner Element	-
5	T158495	1	Valve	-
6	AT175358	1	Rain Cap (Standard)	-
	24-21408	1	Air Pre-cleaner (optional)	-
7	AR35435	2	Mounting Bracket	-
8	19M7784	4	Capscrew, M10 x 1.5 x 20 mm	-
9	14-80811	4	Flange Nut, M10 x 1.5	-
10	R128438	1	Hose	-
11	AT56657	1	Hose Clamp	-
12	AT50923	1	Hose Clamp	-

Air Filter Assembly

NL1064H1

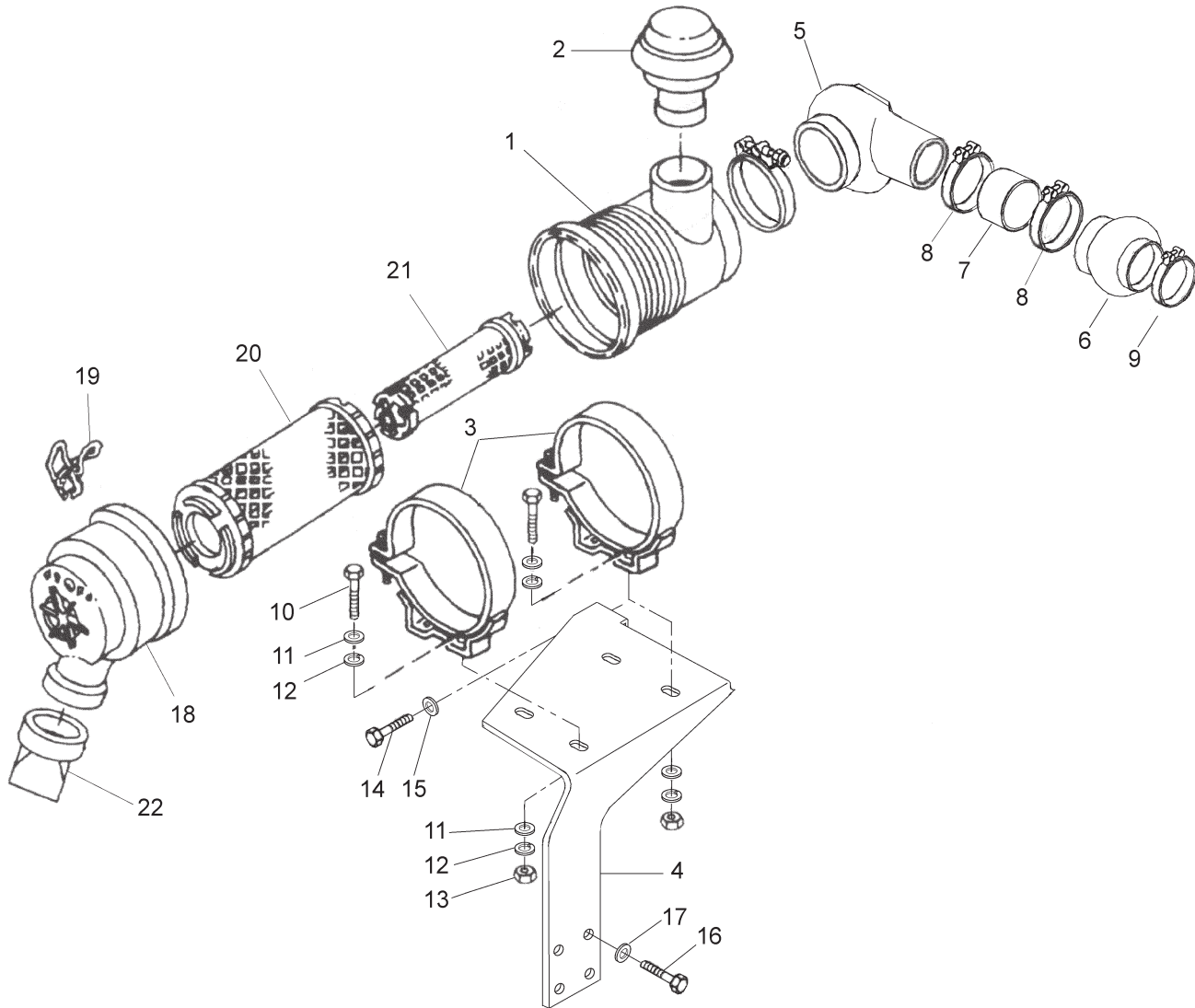

Air Filter Assembly

NL1064H1

KEY	PART NUMBER	QTY	DESCRIPTION	SERIAL NUMBER
1	AT203471	1	Air Filter Assembly	-
2	AT175358	1	Rain Hood	-
3	AR35435	2	Clamp/ Bracket	-
4	23-29406	1	Bracket, Air Filter Mtg.	-
5	18-29401	1	Elbow 4" I.D. 90°	-
6	18-25701	1	Hump Hose 4" x 3" x 5"	-
7	R517439	1	Tube 4" O.D.	-
8	19-01450	3	T-Bolt Clamp 4-1/2" S/S	-
9	19-01350	1	T-Bolt Clamp 3-1/2" S/S	-
10	12-00805	4	Capscrew, Hex Head M10 x 1.5 x 20 mm	-
11	15-00805	8	Flat Washer M10	-
12	15-00802	8	Lock Washer, Helical M10	-
13	14-00812	4	Hex Nut, Nylock M10 x 1.5	-
14	12-00835	1	Capscrew, Hex Head M10 x 1.25 x 25 mm	-
15	15-00301	1	Flat Washer 3/8"	-
16	12-00912	4	Capscrew, Hex Head M12 x 1.75 x 25 mm	-
17	15-00912	4	Lock Washer, Helical M12	-
18	RE501727	1	Cover	-
19	R122386	1	Clip	-
20	AT203469	1	Outer Element	-
21	AT203470	1	Inner Element	-
22	T158495	1	Valve	-

Air Filter Assembly

NL1064H2

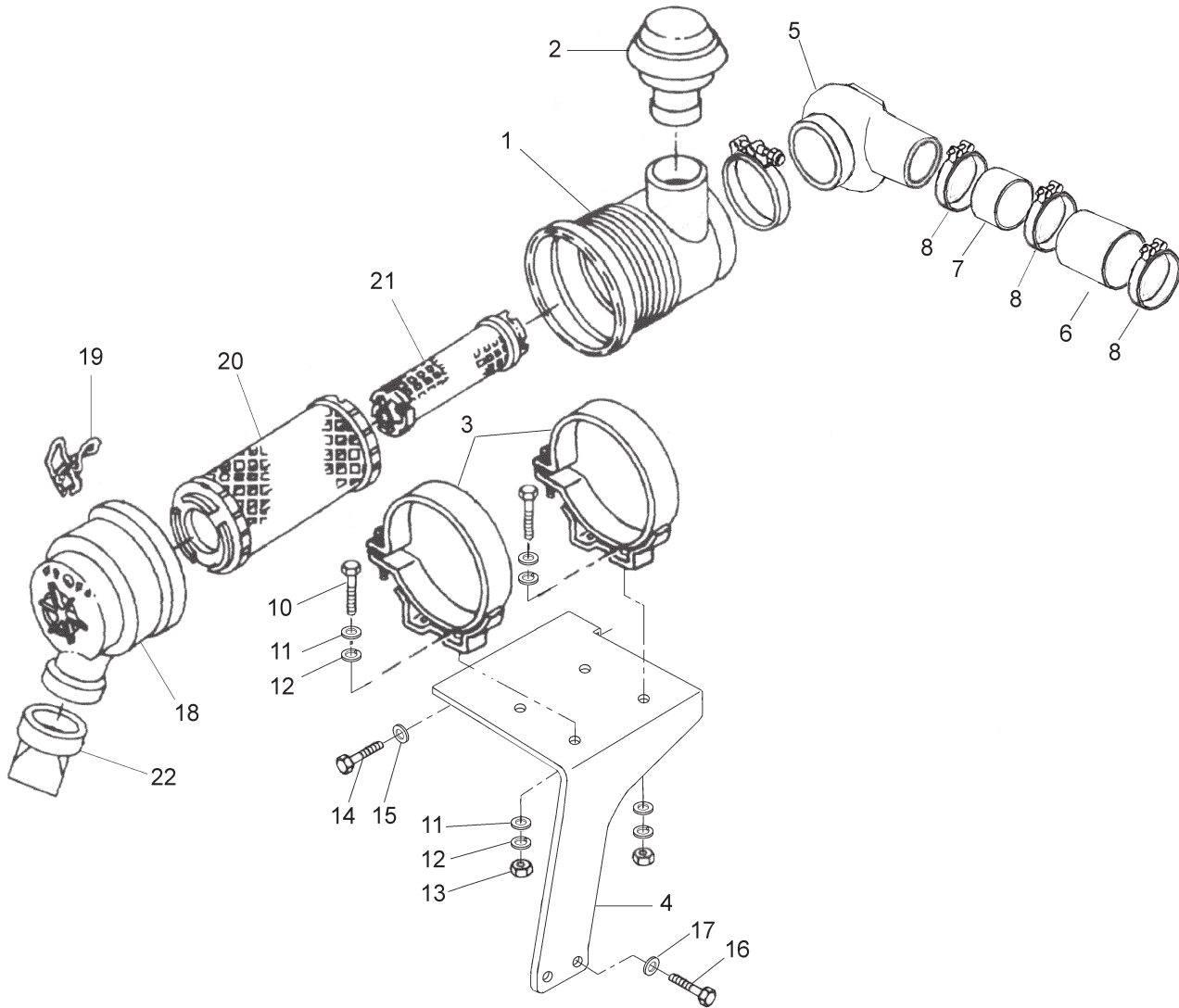

Air Filter Assembly

NL1064H2

KEY	PART NUMBER	QTY	DESCRIPTION	SERIAL NUMBER
1	AT203471	1	Air Filter Assembly	-
2	AT175358	1	Rain Hood	-
3	AR35435	2	Clamp/ Bracket	-
4	23-29404	1	Bracket, Air Filter Mtg.	-
5	18-29401	1	Elbow 4" I.D. 90°	-
6	41-01170	3.5"	Hose 4" I.D.	-
7	R517439	1	Tube 4" O.D.	-
8	19-01450	3	T-Bolt Clamp 4-1/2" S/S	-
10	12-00805	4	Capscrew, Hex Head M10 x 1.5 x 20 mm	-
11	15-00805	8	Flat Washer M10	-
12	15-00802	4	Lock Washer, Helical M10	-
13	14-00812	4	Hex Nut, Nylock M10 x 1.5	-
14	12-00713	2	Capscrew, Hex Head M8 x 1.25 x 35 mm	-
15	15-00701	1	Flat Washer M8	-
16	12-00912	2	Capscrew, Hex Head M12 x 1.75 x 25 mm	-
17	15-00912	2	Lock Washer, Helical M12	-
18	RE501727	1	Cover	-
19	R122386	1	Clip	-
20	AT203469	1	Outer Element	-
21	AT203470	1	Inner Element	-
22	T158495	1	Valve	-

Exhaust Manifold

L- M1064D, M1064T1,T2, & L- M1064A, M40C2

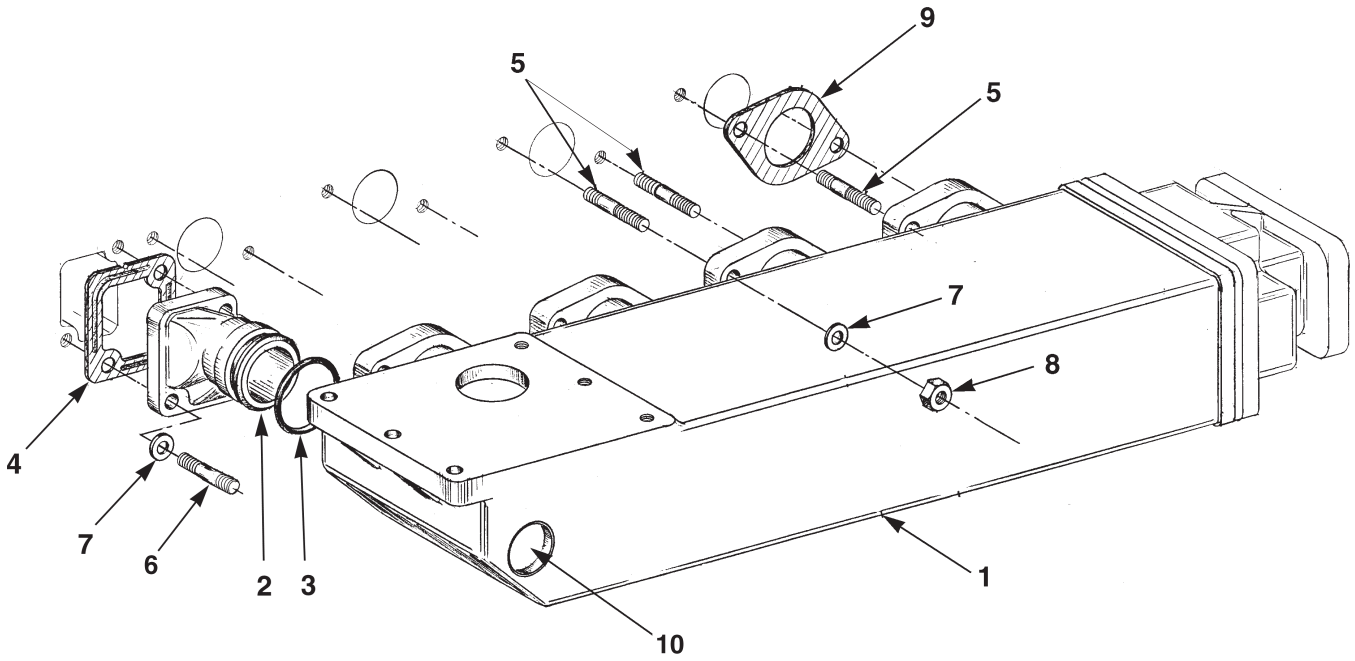

A-8341, A-8342, A-8343 / C-2632

KEY	PART NUMBER	QTY.	DESCRIPTION	SERIAL NUMBER
1	10-31000	1	Exhaust Manifold Assembly w/ Dry Flange*	-
	10-31001	1	Exhaust Manifold Assembly w/ Wet Flange*	-
	10-31002	1	Exhaust Manifold Assembly w/ Wet Elbow Adapter*	-
2	27-11012	1	Coolant Connector	-
3	16-31000	1	O-ring	-
4	11-39501	1	Gasket	-
5	13-34801	8	Stud, M10 x 1.5 x 35 mm	-
6	13-05001	2	Stud, M10 x 1.5 x 25 mm	-
7	15-00300	10	Washer (special)	-
8	14-00810	10	Hex Nut, M10 x 1.5	-
9	11-31011	4	Gasket	-
10	17-10001	5	Expansion Plug	-
*See Exhaust Manifold & Adapter Detail for components				

Exhaust Manifold

M1064H

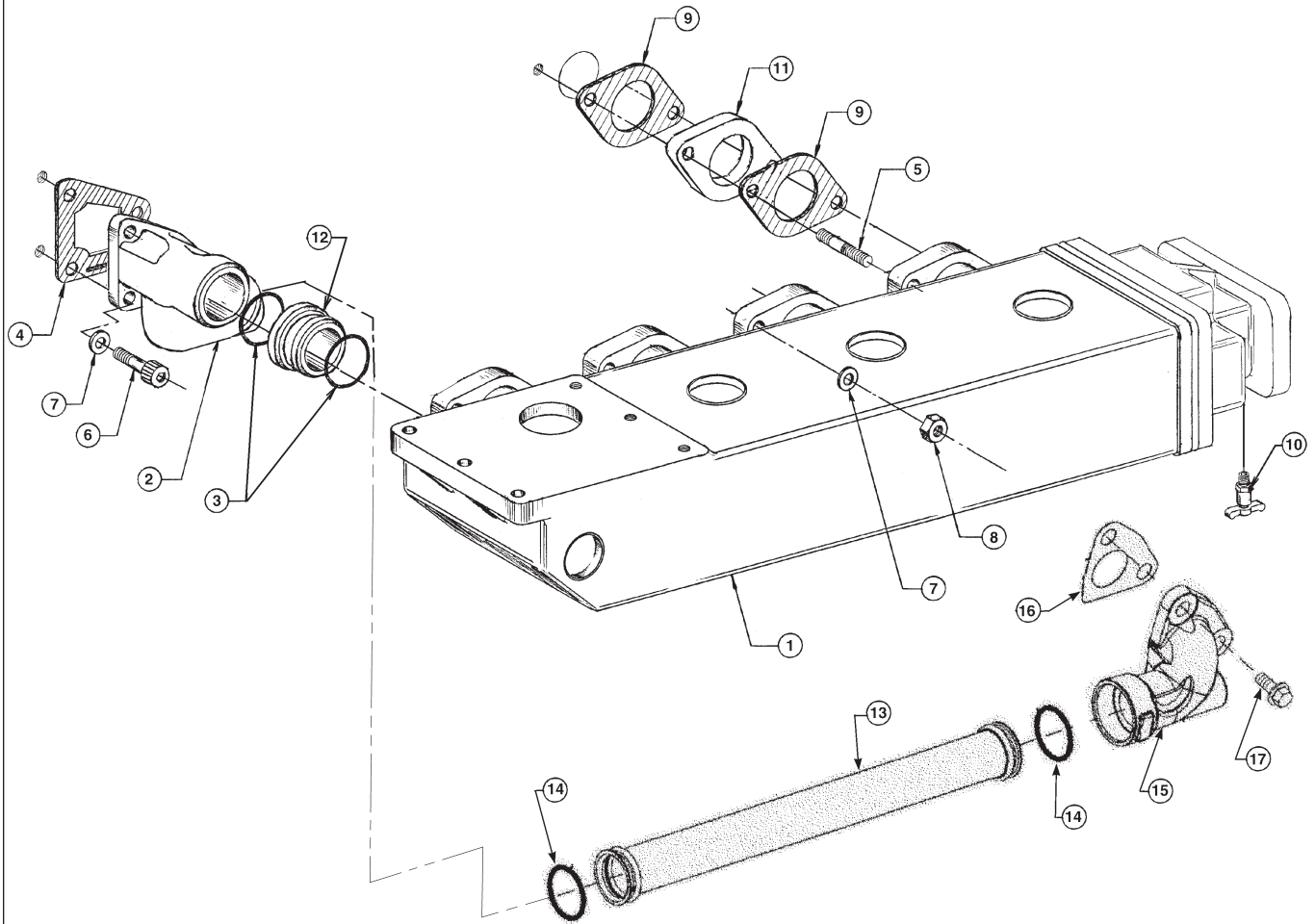

A-10271 / C-5643

KEY	PART NUMBER	QTY.	DESCRIPTION	SERIAL NUMBER
1	10-31001	1	Exhaust Manifold Assembly w/ Wet Flange (see Exhaust Manifold & Adapter detail)	-
2	27-19509	1	Coolant Connector	-
3	16-31000	1	O-Ring	-
4	11-39502	1	Gasket	-
5	13-00816	8	Stud, M10 x 1.5 x 50 mm	-
6	01437-01025	3	Capscrew, 12 Point M10 x 1.5 x 25 mm	-
7	15-00300	11	Flat Washer (special)	-
8	14-00810	8	Hex Nut, M10 x 1.5	-
9	11-31001	8	Gasket (previous # 11-31011)	-
10	21-10001	1	Drain Cock, Brass 1/8 NPT	-
11	28-39501	4	Spacer	-
12	31-19501	1	Coolant Connector	-
13	RE516026	1	Tube	-
14	R63185	2	O-ring	-
15	R504754	1	Manifold	-
16	R505480	1	Gasket	-
17	19M7785	1	Screw	-

GROUP 2 - INTAKE AND EXHAUST SYSTEMS

Exhaust Manifold and Adapter - Marine Application

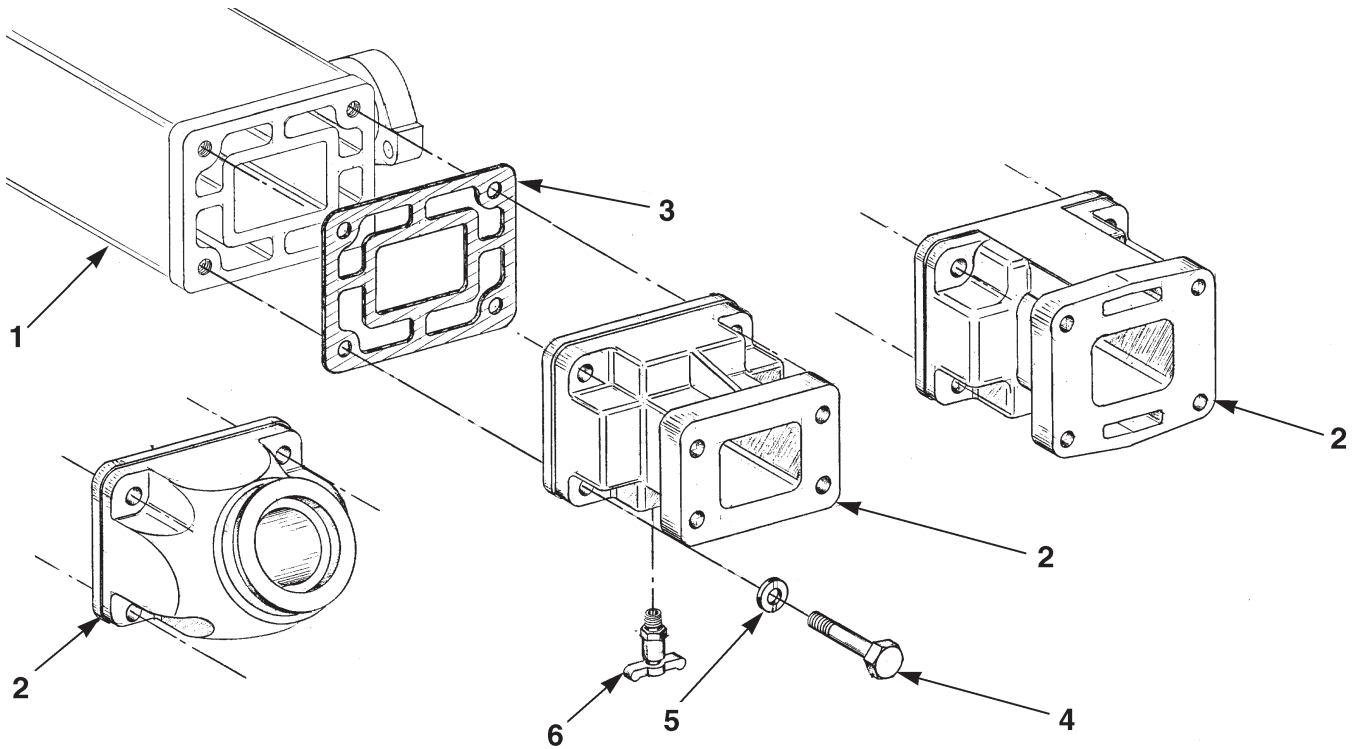

A-4653, A-4654, A-4655, / C-2648

KEY	PART NUMBER	QTY.	DESCRIPTION	SERIAL NUMBER
1	10-31504	1	Exhaust Manifold	-
2	10-31513	1	Dry Exhaust Flange Adapter	-
	10-31506	1	Wet Exhaust Flange for Turbo Mounting	-
	31-31012	1	Wet Exhaust Elbow Adapter	-
3	11-30013	1	Gasket	-
4	12-00414	4	Capscrew, Hex Head 7/16- 14 x 1- 1/2"	-
5	15-00402	4	Lock Washer 7/16	-
6	21-10001	1	Drain Cock 1/8 NPT	-

Exhaust Adapter

L-M1064D, M40C2

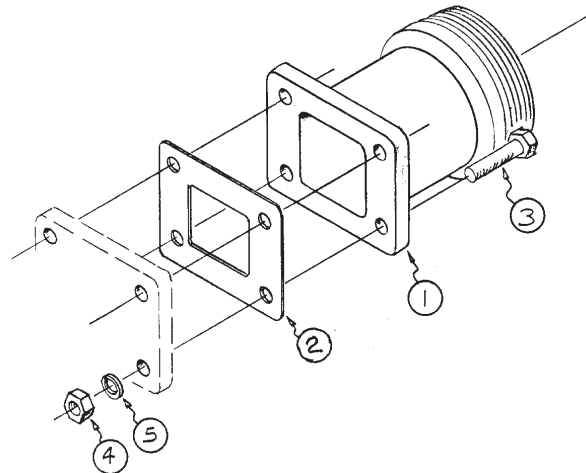

A-459C/ B-1729B

KEY	PART NUMBER	QTY.	DESCRIPTION	SERIAL NUMBER
1	31-31000	1	Exhaust Adapter 3" NPT	-
2	11-31615	1	Gasket	-
3	12-00315	4	Capscrew, Hex Head 3/8-16 x 1-3/4"	-
4	14-00311	4	Hex Nut 3/8-16	-
5	15-00302	4	Lock Washer, Helical 3/8	-

Dry Exhaust Elbow

L-M1064D, M40C2

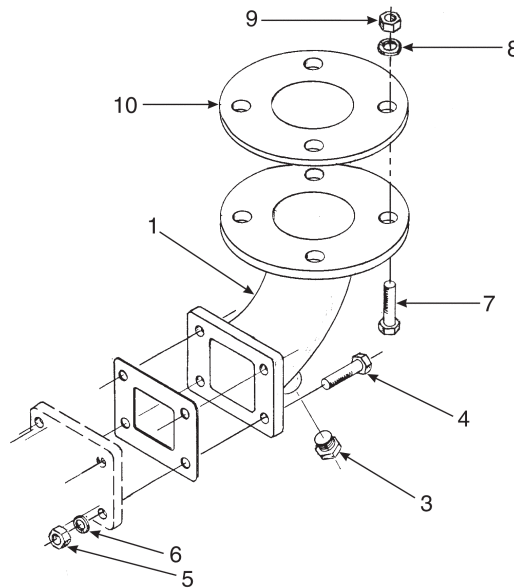

A-457D/ B-1725

KEY	PART NUMBER	QTY.	DESCRIPTION	SERIAL NUMBER
1	27-31011	1	Dry Exhaust Elbow 3"	-
2	11-31615	1	Gasket	-
3	21-31002	1	Plug, Square Head Brass 3/8 NPT	-
4	12-00315	4	Capscrew, Hex Head 3/8-16 x 1-3/4"	-
5	14-00311	4	Hex Nut 3/8-16	-
6	15-00302	4	Drain Cock 1/8NPT	-
7	12-00914	4	Capscrew, Hex Head 5/8-11 x 1-3/4"	-
8	15-00902	4	Lock Washer, Helical 5/8	-
9	14-00911	4	Hex Nut 5/8-11	-
10	11-31094	1	Gasket	-

Dry Exhaust Elbow

L1064A, M1064T1, T2, A, H, M55C2, M65C2

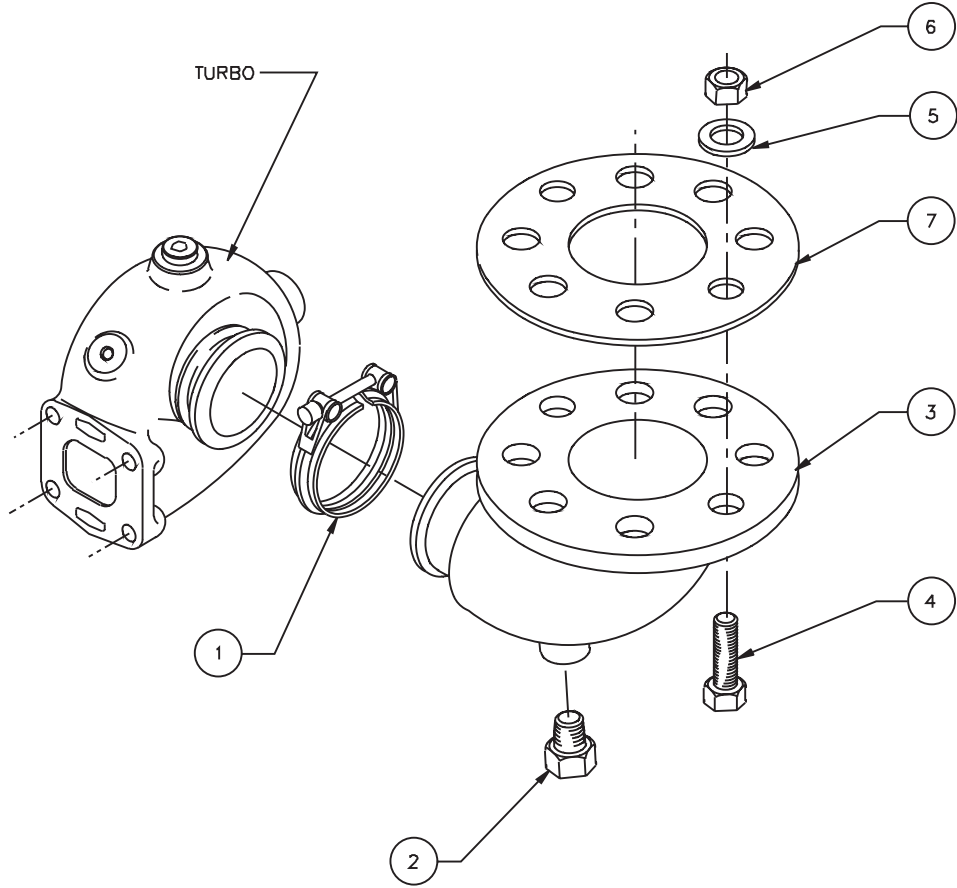

A-6337/ B-4638

KEY	PART NUMBER	QTY.	DESCRIPTION	SERIAL NUMBER
1	19-31401	1	V-Clamp	-
2	21-31002	1	Plug, Square Head Brass 3/8 NPT	-
3	27-31407	1	Dry Exhaust Elbow 3"	-
4	12-00916	8	Capscrew, Hex Head 5/8-11 x 2"	-
5	15-00902	8	Lock Washer, Helical 5/8	-
6	14-00911	8	Hex Nut 5/8-11	-
7	11-31099	1	Gasket	-

4" Wet Exhaust Elbow L1064D (Heat Exchanged Units)

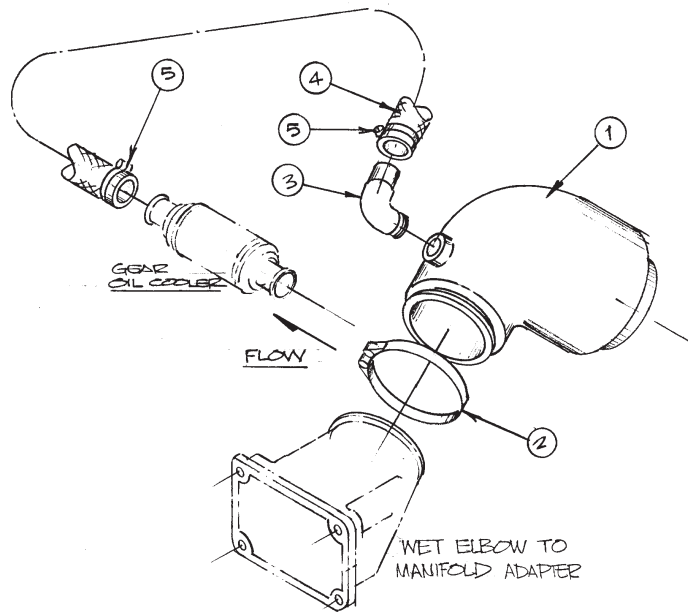

A-3023/ B-2919

KEY	PART NUMBER	QTY.	DESCRIPTION	SERIAL NUMBER
1	27-31412	1	Wet Exhaust Elbow 4"	-
2	19-31401	1	V-Clamp	-
3	21-31007	1	Male Elbow, Copper 1" NPT x 1-1/4" HB	-
4	18-31605	1	Hose, 1-1/4 x 32" Wire Reinforced	-
5	19-00016	2	Hose Clamp #16	-

5" Wet Exhaust Elbow L1064A

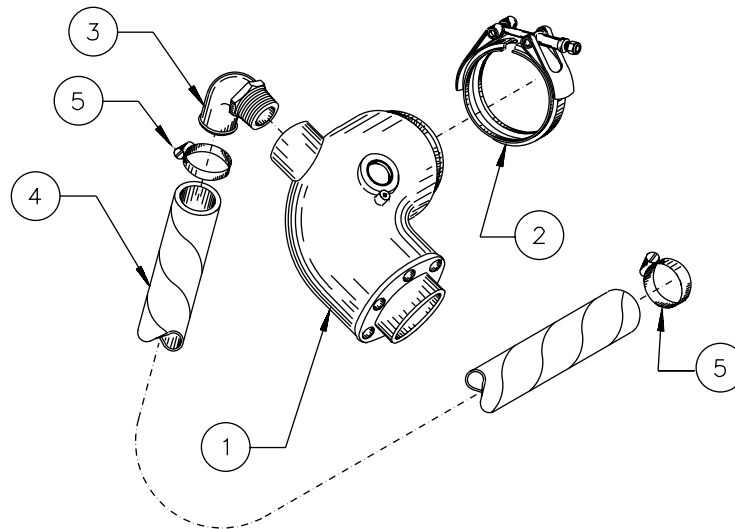

A-10809/ B-2918B

KEY	PART NUMBER	QTY.	DESCRIPTION	SERIAL NUMBER
1	27-30047	1	Wet Exhaust Elbow 5"	-
2	19-31401	1	V-Clamp	-
3	21-19503	1	Male Elbow, Copper 1-1/4" NPT x 1-3/4" Hose Barb	-
4	41-01092	1	Hose, 1-3/4" x 32" Wire Reinforced	-
5	19-00032	2	Hose Clamp #32	-

GROUP 2 - INTAKE AND EXHAUST SYSTEMS

4" Wet Exhaust Elbow (Heat Exchanged Units)

M1064D, M1064T1, T2, A, H, M40C2, M55C2, & M65C2

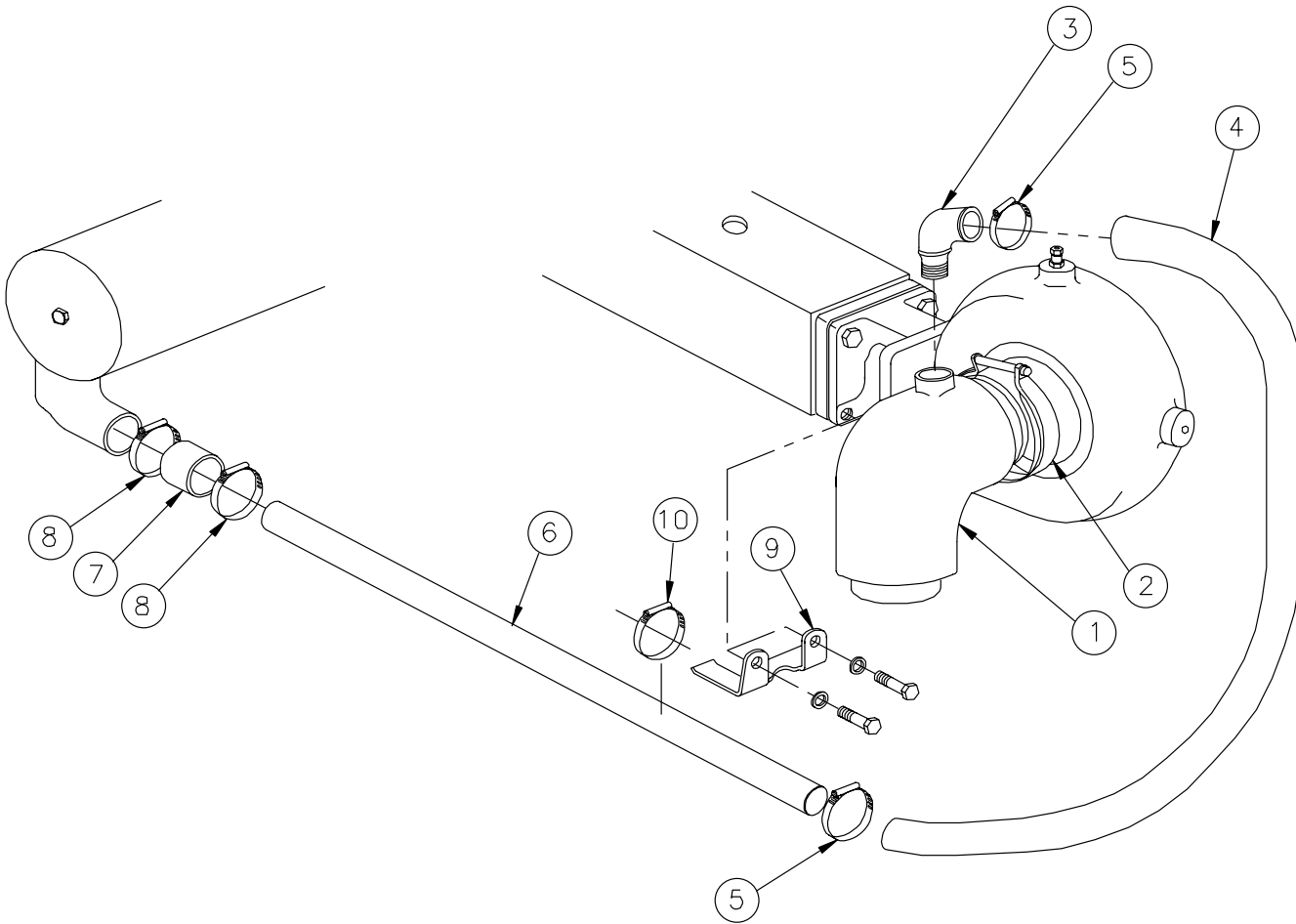

A-10403, A-8514, A-8512/ B-8609

KEY	PART NUMBER	QTY.	DESCRIPTION	S/N
1	27-31412	1	Elbow, Wet Exhaust 4"	-
2	19-31401	1	V-Clamp	-
3	21-31005	1	Male Elbow, 90° Copper 1" NPT x 1-5/8" HB (M1064A & H)	-
	21-31007	1	Male Elbow, 90° Copper 1" NPTx 1-1/4" HB (M1064D, T1, T2, M40C2, M55C2, M65C2)	-
4	41-14801	36"	Hose, 1-5/8" ID, Wire Reinforced (M1064A & H)	-
	41-01070	24"	Hose, 1-1/4" ID, Wire Reinforced (M1064D, T1, T2, M40C2, M55C2, M65C2)	-
5	19-00028	2	Hose Clamp, #28	-
	19-00020	2	Hose Clamp, #20	-
6	27-19406	1	Tube, Raw Water Discharge (M1064A & H)	-
	27-19503	1	Tube, Raw Water Discharge S/S (M1064T1, T2, M55C2, M65C2)	-
	27-19504	1	Tube, Raw Water Discharge S/S (M1064D, M40C2)	-
7	18-26002	1	Hose, 2" ID x 2-3/4" 4 Ply Silicone (M1064A & H)	-
	18-19501	1	Hose, 1-1/4" ID x 2-1/2" 3 Ply Silicone (M1064D, T1, T2, M40C2, M55C2, M65C2)	-
8	19-01032	2	Hose Clamp, #32 Extended Band S/S (M1064A & H)	-
	19-01020	2	Hose Clamp, #20 Extended Band S/S (M1064D, T1, T2, M40C2, M55C2, M65C2)	-
9	23-19507	1	Bracket, Tube Support (M1064A & H)	-
	23-19503	1	Bracket, Tube Support (M1064D, T1, T2, M40C2, M55C2, M65C2)	-
10	19-00020	1	Hose Clamp #20 (M1064A & H)	-
	19-00016	1	Hose Clamp #16 (M1064D, T1, T2, M40C2, M55C2, M65C2)	-

Exhaust Manifold - Rear Outlet

NL1064D

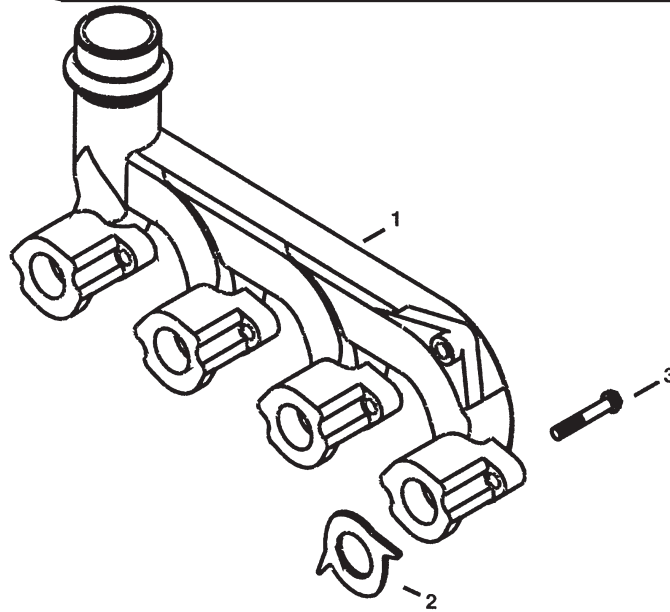

Reproduced by permission of Deere & Co., c2005. Deere & Company. All rights reserved.

RGP6149

KEY	PART NUMBER	QTY	DESCRIPTION	SERIAL NUMBER
1	R121669	1	Exhaust Manifold	-
2	R521439	4	Gasket (formerly # R90658)	-
3	19M7810	8	Screw, M10 x 80	-

Exhaust Manifold - Front Outlet

NL1064D

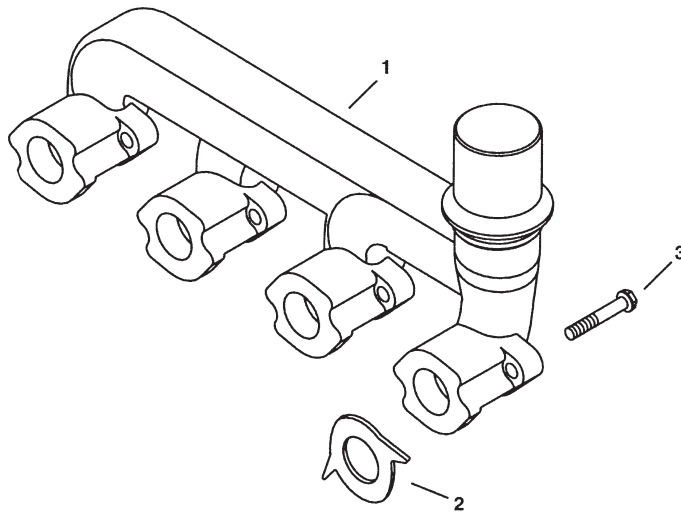

Reproduced by permission of Deere & Co., c2005. Deere & Company. All rights reserved.

RGP6150

KEY	PART NUMBER	QTY	DESCRIPTION	SERIAL NUMBER
1	R122497	1	Exhaust Manifold	-
2	R521439	4	Gasket (formerly # R90658)	-
3	19M7810	1	Screw, M10 x 80	-

Exhaust Manifold

NL1064T1, T2, H1, & H2

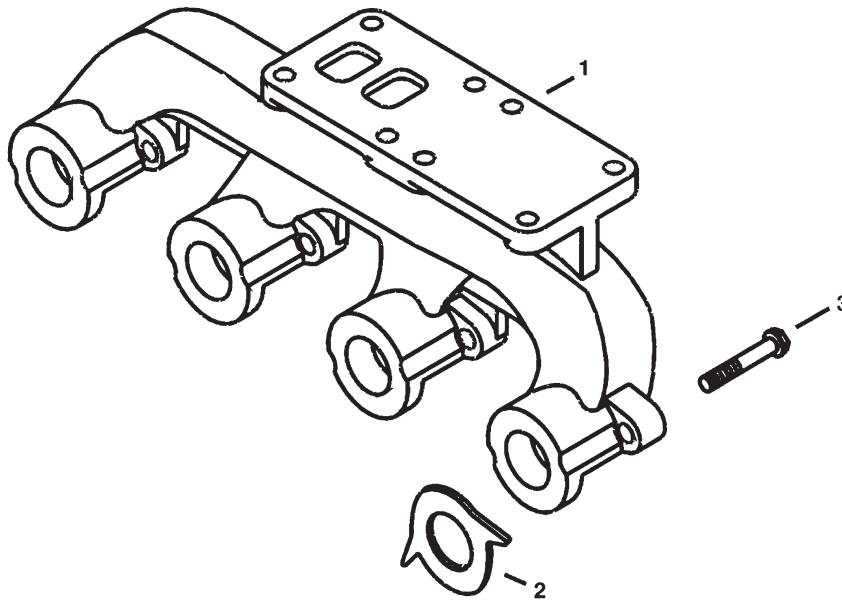

Reproduced by permission of Deere & Co., c2005. Deere & Company. All rights reserved.

RGP6147

KEY	PART NUMBER	QTY	DESCRIPTION	SERIAL NUMBER
1	R517017	1	Exhaust Manifold (formerly #R132373)	-
2	R90658	4	Gasket	-
3	19M7810	8	Screw, M10 x 80	-

Turbocharger

NL1064T1, T2, & H1

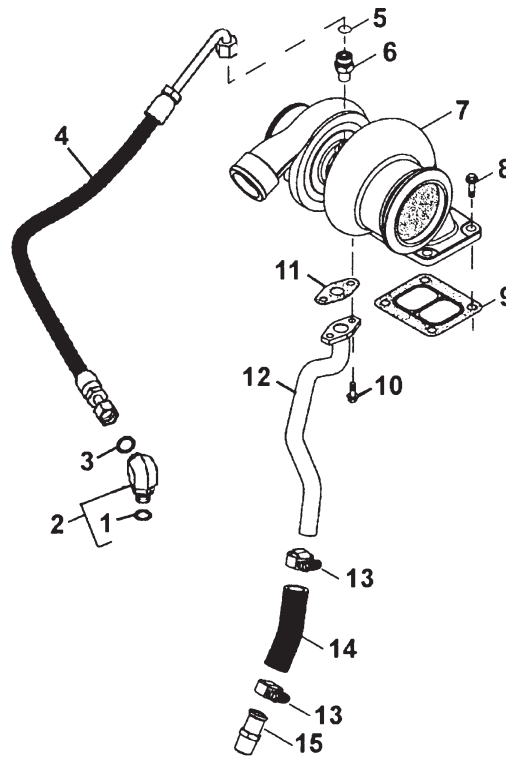

Reproduced by permission of Deere & Co., c2005. Deere & Company. All rights reserved.

RGF8601

KEY	PART NUMBER	QTY	DESCRIPTION	SERIAL NUMBER
1	51M7042	1	O-ring	-
2	38H5154	1	Elbow Fitting	-
3	T77613	1	O-ring	-
4	RE501260	1	Oil Line	-
5	M63548	1	O-ring	-
6	R87733	1	Adapter	-
7	RE516784	1	Turbocharger (marked RE516753, remanufactured)	-
8	19M7785	4	Screw, M10 x 25	-
9	R123572	1	Gasket	-
10	19M7866	2	Screw, M8 x 20	-
11	R123570	1	Gasket	-
12	RE59547	1	Oil Line	-
13	RE65978	2	Clamp	-
14	R120013	1	Bulk Hose	-
15	RE54885	1	Hose Fitting	-

GROUP 2 - INTAKE AND EXHAUST SYSTEMS

Turbocharger

NL1064H2

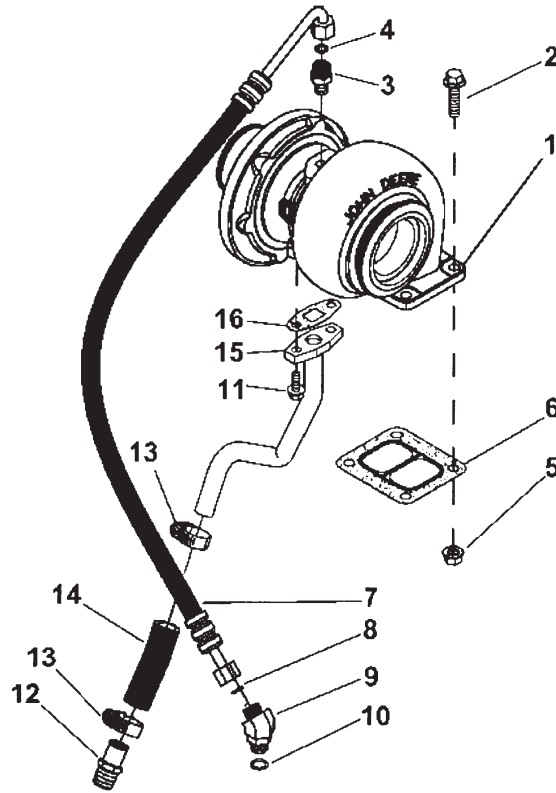

Reproduced by permission of Deere & Co., c2005. Deere & Company. All rights reserved.

RE517151SPA

KEY	PART NUMBER	QTY	DESCRIPTION	SERIAL NUMBER
1	RE517248	1	Turbocharger (marked RE517236, remanufactured) (1800 rpm)	-
1	RE516784	1	Turbocharger (marked RE517799 - remanufactured) (1500 rpm)	-
2	19M8162	4	Screw, M10 x 40	-
3	M87733	1	Adapter	-
4	R63548	1	O-ring	-
5	14M7296	4	Flange Nut, M10	-
6	R123572	1	Gasket	-
7	RE503212	1	Hydraulic Hose (use with turbo RE517248)	-
	RE501260	1	Hydraulic Hose (use with turbo RE516784)	-
8	T77613	1	O-ring	-
9	38H5037	1	Adapter	-
10	T77613	1	O-ring	-
11	19M7866	2	Screw, M8 x 20	-
12	RE54885	1	Hose Fitting	-
13	RE65978	2	Clamp	-
14	R120013	**	Bulk Hose	-
15	RE516008	1	Oil Line	-
16	R123570	1	Gasket	-
			**As required	

Dry Exhaust Elbow

NL1064T1, T2, H1, & H2

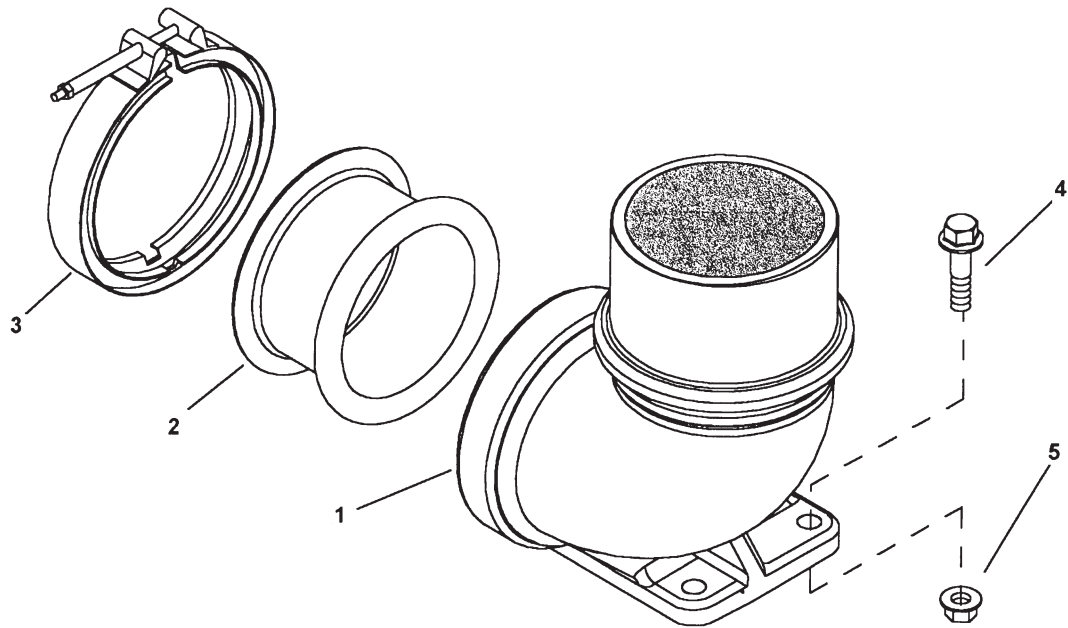

Reproduced by permission of Deere & Co., c2005. Deere & Company. All rights reserved.

RGP6262

KEY	PART NUMBER	QTY	DESCRIPTION	SERIAL NUMBER
1	R123246	1	Pipe Elbow	-
2	R87732	1	Adapter	-
3	RE40048	1	Clamp	-
4	19M8162	4	Screw, M10 x 40	-
5	14M7296	4	Flange Nut, M10	-

Exhaust Adapter 3"

NL1064D

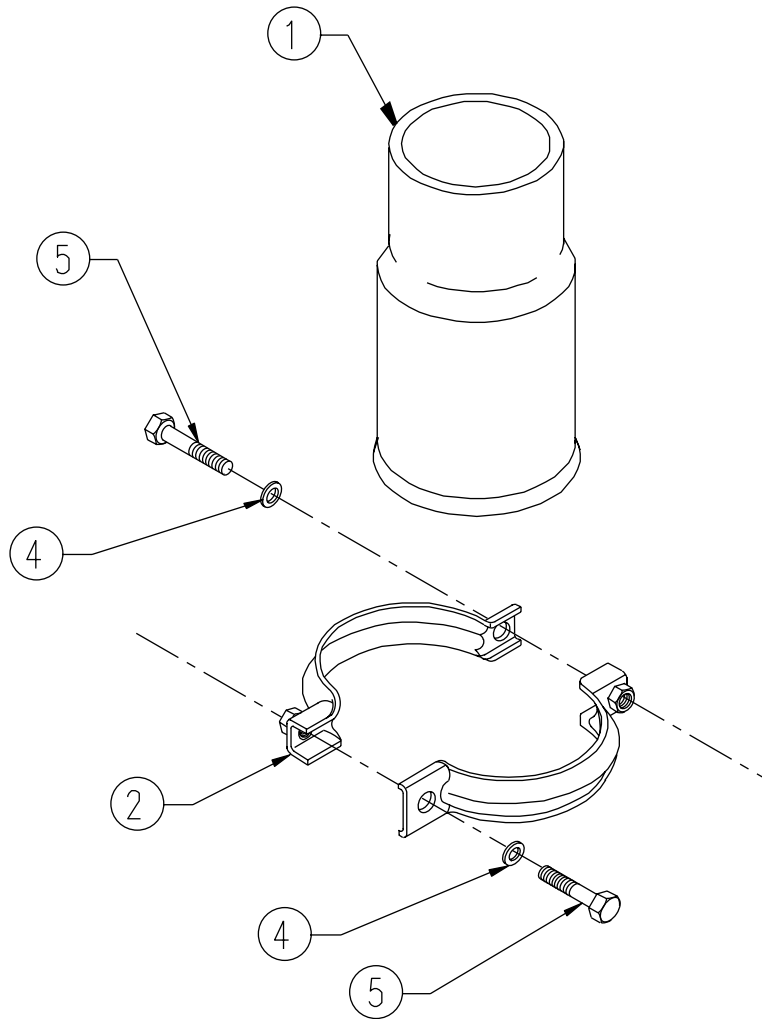

A-1162B/ B-8696

KEY	PART NUMBER	QTY	DESCRIPTION	SERIAL NUMBER
1	31-31003	1	Exhaust Adapter 3" NPT Male	-
2	AT63813	2	Half Clamp	-
4	15-00202	2	Lock Washer Helical 5/16	-
5	12-00214	2	Capscrew, Hex Head 5/16- 18 x 1- 1/2"	-

Exhaust Adapter 3"

NL1064D

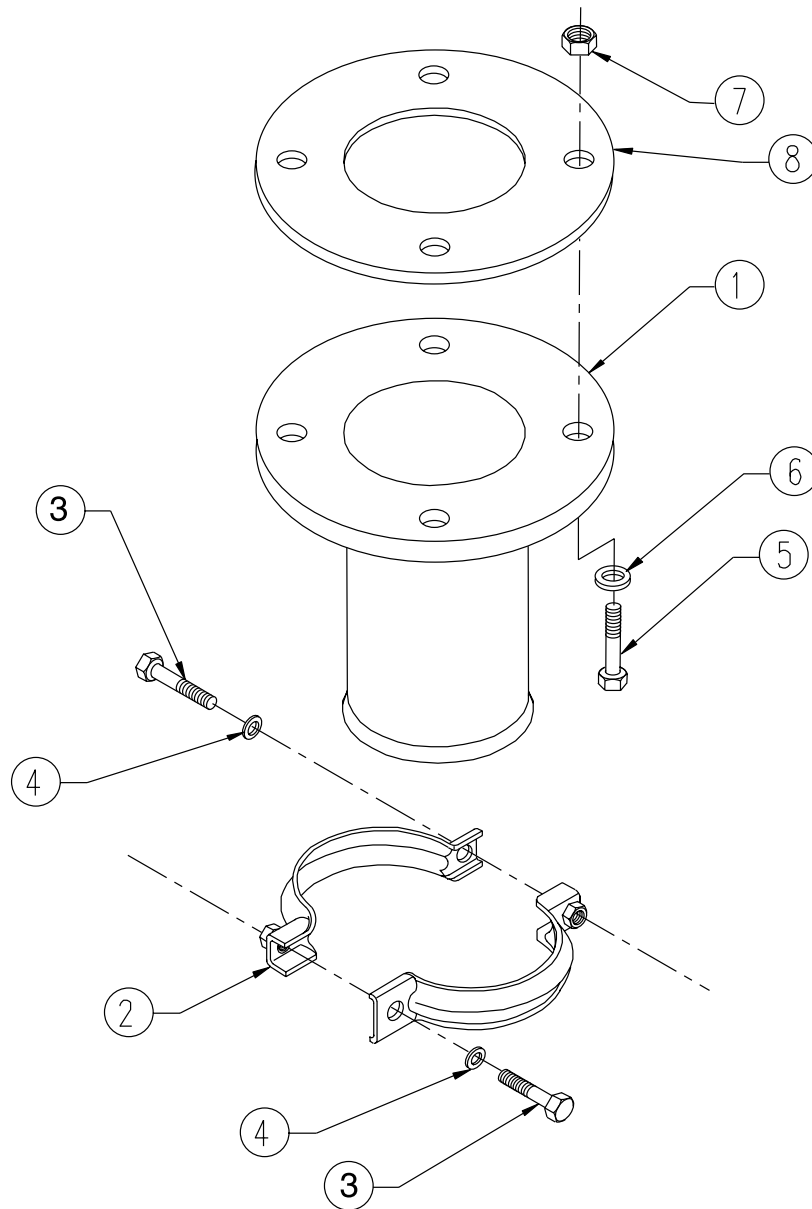

A-6294/ B-8697

KEY	PART NUMBER	QTY	DESCRIPTION	SERIAL NUMBER
1	31-31008	1	Exhaust Adapter 3"	-
2	AT63813	2	Half Clamp with Integral Nut	-
3	12-00214	2	Capscrew, Hex Head 5/16- 18 x 1- 1/2"	-
4	15-00221	2	Flat Washer 5/16" SAE	-
5	12-00914	4	Capscrew, Hex Head 5/8- 11 x 1- 3/4"	-
6	15-00902	4	Lock Washer Helical 5/8"	-
7	14-00911	8	Hex Nut 5/8- 11	-
8	11-31094	1	Gasket	-

Exhaust Adapter 4"

NL1064T1, T2, H1, & H2

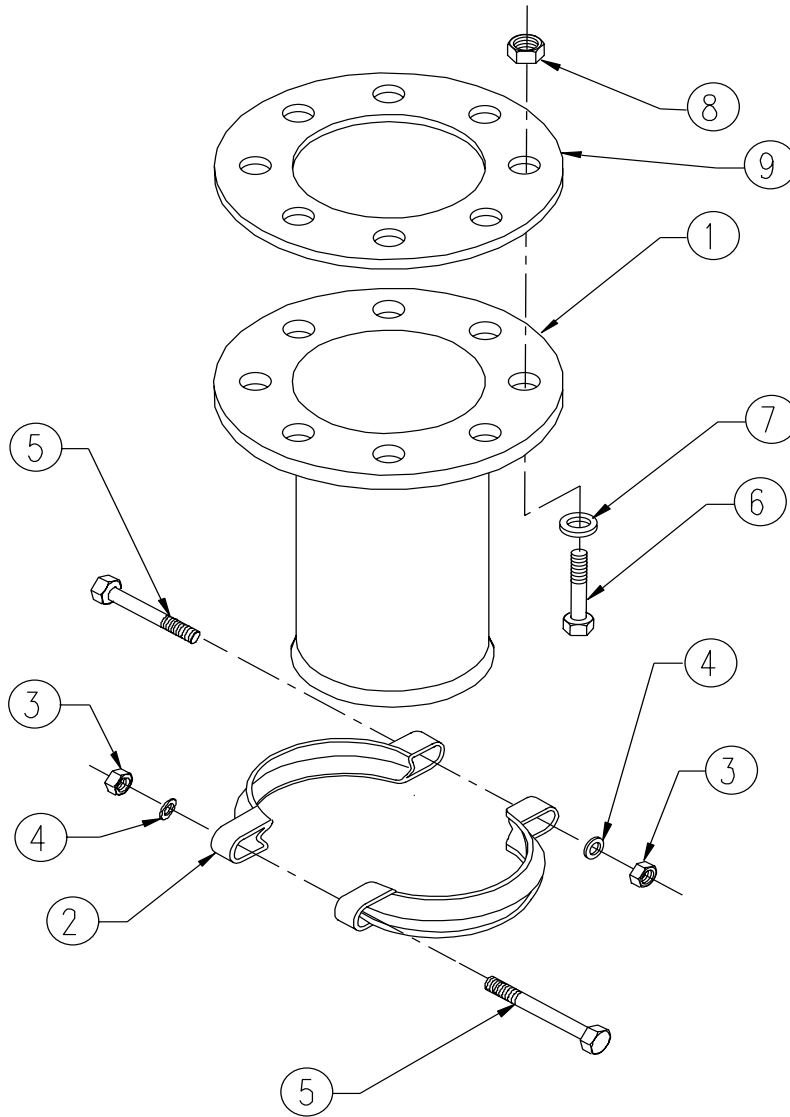

A-1088E, A-6861A/ B-1566B

KEY	PART NUMBER	QTY	DESCRIPTION	SERIAL NUMBER
1	31-31066	1	Exhaust Adapter 4"	-
	27-31009	1	Exhaust Flex S/S 4" x 18" (NL1064T1, T2, H1, & H2, not shown)	-
2	AR43704	2	Clamp kit with fasteners (includes keys 3-5)	-
3	14-00311	2	Hex Nut 3/8- 16	-
4	15-00321	4	Flat Washer 3/8" SAE	-
5	12-00310	2	Capscrew, Hex Head 3/8- 16 x 3"	-
6	12-00914	8	Capscrew, Hex Head 5/8- 11 x 1- 3/4"	-
7	15-00902	8	Lock Washer Helical 5/8"	-
8	14-00911	8	Hex Nut 5/8- 11	-
9	11-31099	1	Gasket	-

K26 Turbocharger Assembly

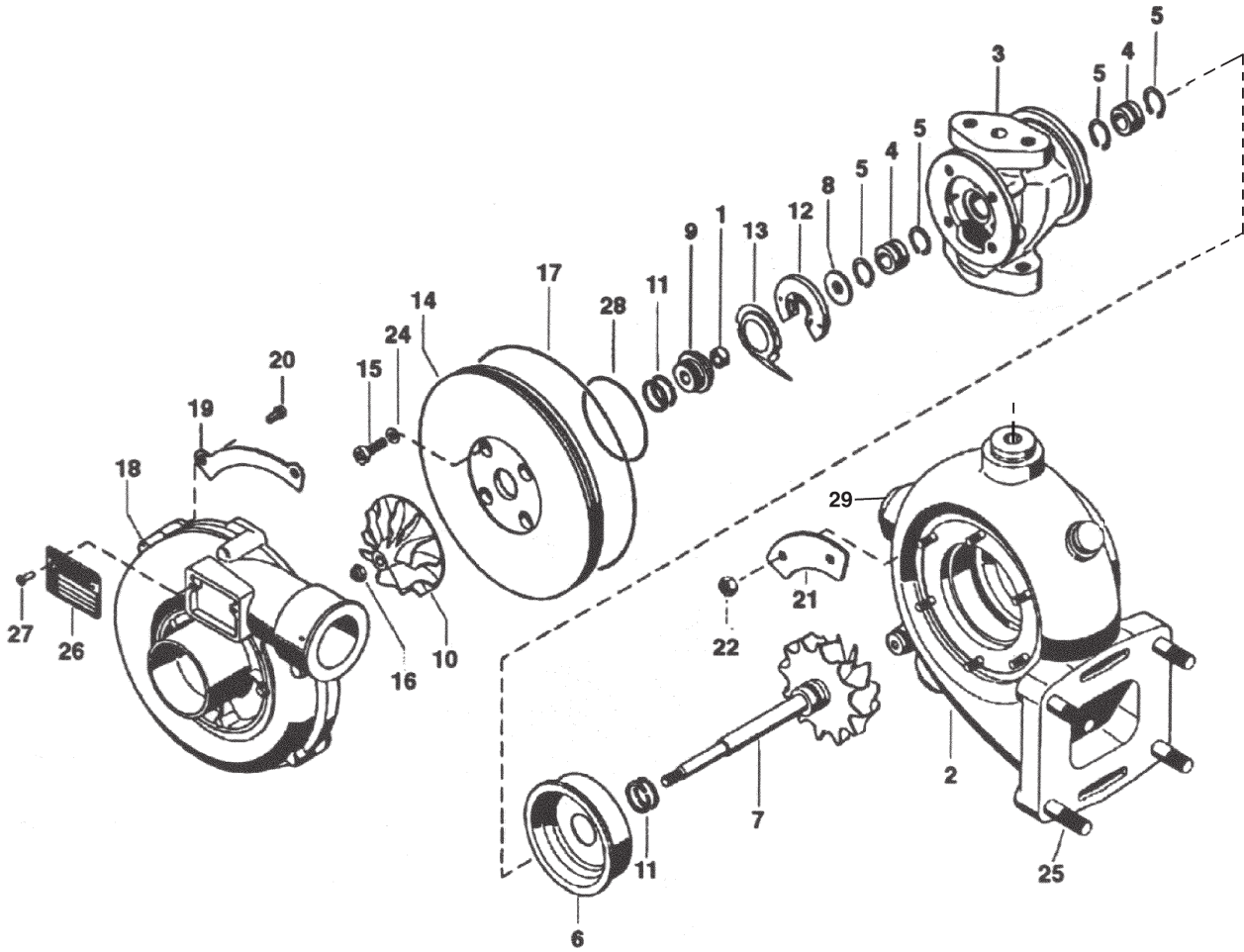

K26 Turbocharger Assembly

KEY	PART NUMBER	QTY	DESCRIPTION	SERIAL NUMBER
••	30-31426-1	1	Turbocharger Assembly (ID Tag #5326 988 64 93 - includes all keys)	-
••	30-21400-1	1	Turbocharger Assembly (ID Tag #5326 988 60 90 - includes all keys)	-
••	30-39400	1	Turbocharger Assembly (ID Tag #5326 988 60 86 - includes all keys)	-
•	30-31430	1	Repair Kit (includes keys 4,5, 11-17, 19-22, 24, & 28)	-
1	30-31662	1	Spacer Sleeve	-
2	30-31401	1	Turbine Housing (10.0 for turbocharger 30-31426-1)	-
	30-31431	1	Turbine Housing (8.0 for turbocharger 30-21400-1)	-
	30-39401	1	Turbine Housing (6.0 for turbocharger 30-39400)	-
3	30-31433	1	Bearing Housing	-
4	30-31434	2	Bushing	-
5	30-31435	4	Snap Ring	-
6	30-31436	1	Heat Shield	-
7	30-31437	1	Shaft & Turbine Wheel Assembly	-
8	30-31438	1	Thrust Ring	-
9	30-31439	1	Flinger Sleeve	-
10	30-39403	1	Compressor Wheel (for 30-39400 turbocharger)	-
	30-21401	1	Compressor Wheel (for 30-21400 turbocharger)	-
	30-31440	1	Compressor Wheel (for 30-31426-1 turbocharger)	-
11	30-31441	4	Piston Ring	-
12	30-31442	1	Thrust Bearing	-
13	30-31443	1	Oil Deflector	-
14	30-31444	1	Backing Plate	-
15	30-31445	4	Capscrew, Socket & Head, M6 x 1.0 x 16 mm Grade 10.9	-
16	30-39611	1	Lock Nut, M7 x 1 (Left hand)	-
17	30-31447	1	O-ring	-
18	30-39402	1	Compressor Housing (for 30-39400 turbocharger)	-
	30-21402	1	Compressor Housing (for 30-21400-1 turbocharger)	-
	30-31432	1	Compressor Housing (for 30-31426-1 turbocharger)	-
19	30-31448	3	Clamp Plate (compressor side)	-
20	30-39614	6	Capscrew, Socket Head M6 x 1.0 x 14 mm	-
21	30-31450	3	Clamp Plate (turbine side)	-
22	14-01131	6	Hex Nut M6 x 1.0	-
23	30-31452	6	Stud, M6 x 1.0	-
24	30-31453	4	Flat Washer, M6	-
25	13-00814	4	Stud, M10 x 1.5 x 30 mm	-
26	30-31454	1	Name Plate	-
27	30-31455	2	Rivet	-
28	30-31428	1	O-ring	-
29	30-31631	2	Plug, Socket Head, Steel M22 x 1.5	-

Expansion Tank Assembly

L- M1064D, M1064T1-T2, L- M1064A, M40C2, M55C2, & M65C2

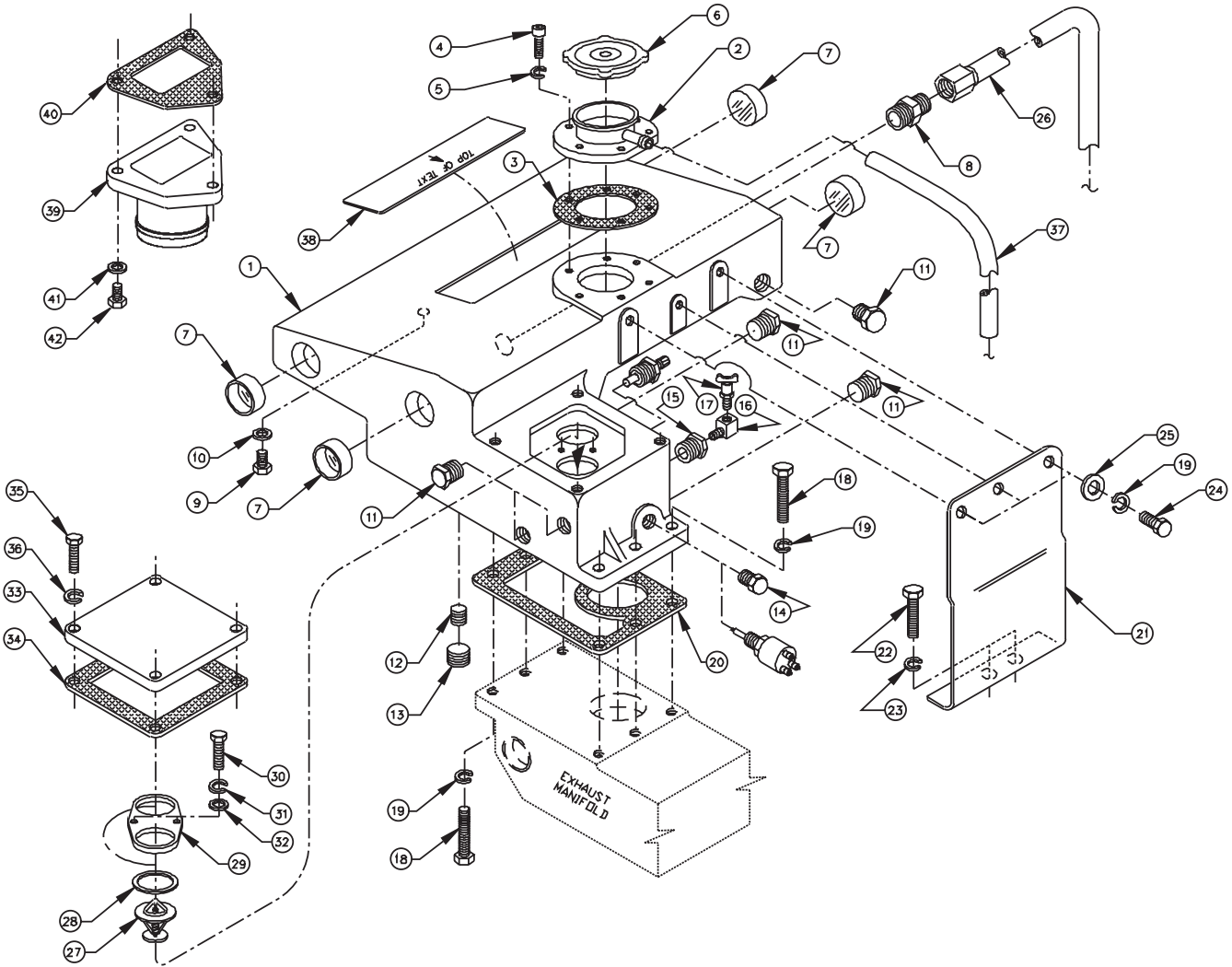

A-8340A/ C-5005

Expansion Tank Assembly

L- M1064D, M1064T1-T2, L- M1064A, M40C2, M55C2, & M65C2

KEY	PART NUMBER	QTY	DESCRIPTION	SERIAL NUMBER
1	10-19501	1	Expansion Tank	-
2	10-11023	1	Filler Neck Assembly	-
3	11-11022	1	Gasket	-
4	12-20111	6	Capscrew, Socket Head, 1/4-20 x 3/4	-
5	15-00018	6	Lock Washer, High Collar, 1/4	-
6	21-19510	1	Filler Cap	-
7	17-10001	4	Expansion Plug	-
8	21-74801	1	Male Connector, Steel, 3/4 NPT x 5/8-37T	-
9	12-00098	1	Capscrew, Hex Head 1/4-20 x 1/2" S/S	-
10	15-19502	1	Sealing Washer	-
11	21-00530	**	Plug, Hex Head, Brass, 1/2 NPT	-
12	21-11003	1	Plug, Socket Head, Steel, 1/2 NPT	-
13	21-11004	1	Plug, Socket Head, Steel, 3/4 NPT	-
14	21-31003	**	Plug, Hex Head, Brass, 3/8 NPT	-
15	21-00136	1	Bushing, Brass, 1/2 NPT x 1/8 NPT	-
16	21-72044	1	Street Elbow 90 Degrees, Brass, 1/8 NPT	-
17	21-10001	1	Drain Cock, Brass, 1/8 NPT	-
18	12-00313	6	Capscrew, Hex Head 3/8-16 x 1-1/4"	-
19	15-00302	9	Lock Washer, Helical 3/8	-
20	11-11023	1	Gasket	-
21	23-19502	1	Bracket	-
22	12-00831	2	Capscrew, Hex Head, M10 x 1.5 x 25 mm	-
23	15-00802	2	Lock Washer, Helical M10	-
24	12-00311	3	Capscrew, Hex Head, 3/8-16 x 3/4"	-
25	15-00301	3	Flat Washer, 3/8"	-
26	27-19501	1	Tube Assembly	-
27	35-11000	1	Thermostat, 180°F/ 82°C	-
	35-11007	1	Thermostat, 190°F/ 88°C	-
28	11-10015	2	Seal Ring	-
29	35-11004	1	Clamp	-
30	12-00223	2	Capscrew, Hex Head, 5/16-18 x 3/4" S/S	-
31	15-00222	2	Lock Washer, Helical 5/16" S/S	-
32	15-11000	2	Flat Washer, 5/16 USS S/S	-
33	10-11024	1	Cover	-
34	11-11013	1	Gasket	-
35	12-00212	4	Capscrew, Hex Head 5/16-18 x 1"	-
36	15-00202	4	Lock Washer, Helical 5/16	-
37	41-01013	30"	Hose, 5/16" I.D., Polyvinyl	-
38	00-71000	1	Nameplate "Lugger"	-
	00-00006	1	Nameplate "Northern Lights"	-
39	10-11006	1	Keel Cooling Outlet (Generator Units)	-
40	11-11043	1	Gasket	-
41	15-00302	3	Lock Washer, 3/8	-
42	12-00313	3	Capscrew, Hex Head 3/8-16 x 1-1/4"	-
43	21-00027	**	Plug, Socket Head, Brass 1/8 NPT	-
44	21-51901	**	Plug, Socket Head, Brass 1/4 NPT	-

} Keel Cooled Only

**As required

Expansion Tank Assembly

M1064H

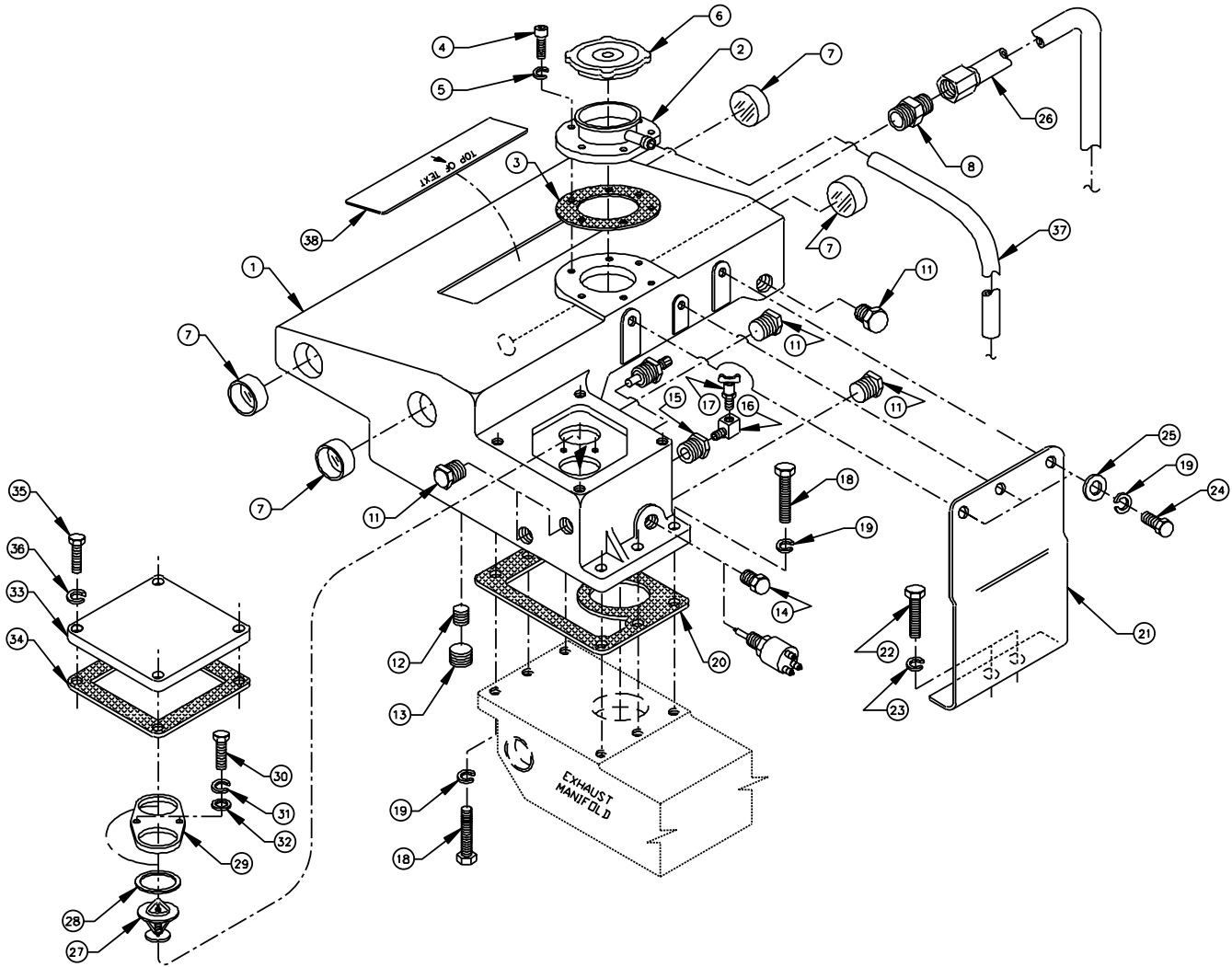

A-10160/ C-5005z

Expansion Tank Assembly

M1064H

KEY	PART NUMBER	QTY	DESCRIPTION	SERIAL NUMBER
1	10-19501	1	Expansion Tank	-
2	10-11023	1	Filler Neck Assembly	-
3	11-11022	1	Gasket	-
4	12-20111	6	Capscrew, Socket Head, 1/4-20 x 3/4	-
5	15-00018	6	Lock Washer, High Collar, 1/4	-
6	21-10007	1	Filler Cap	-
7	17-10001	4	Expansion Plug	-
8	21-74801	1	Male Connector, Steel 3/4 NPT x 5/8- 37T	-
9	21-00027	**	Plug, Socket Head, Brass 1/8 NPT (not shown)	-
10	21-51901	**	Plug, Socket Head, Brass 1/4 NPT (not shown)	-
11	21-00530	**	Plug, Hex Head, Brass, 1/2 NPT	-
12	21-11003	1	Plug, Socket Head, Steel, 1/2 NPT	-
13	21-11004	1	Plug, Socket Head, Steel, 3/4 NPT	-
14	21-31003	**	Plug, Hex Head, Brass, 3/8 NPT	-
15	21-00136	1	Bushing, Brass, 1/2 NPT x 1/8 NPT	-
16	21-72044	1	Street Elbow 90 Degrees, Brass, 1/8 NPT	-
17	21-10001	1	Drain Cock, Brass, 1/8 NPT	-
18	12-00313	6	Capscrew, Hex Head 3/8-16 x 1-1/4"	-
19	15-00302	9	Lock Washer, Helical 3/8	-
20	11-11023	1	Gasket	-
21	23-19506	1	Bracket	-
22	12-00831	2	Capscrew, Hex Head, M10 x 1.5 x 25 mm	-
23	15-00802	2	Lock Washer, Helical M10	-
24	12-00311	3	Capscrew, Hex Head, 3/8-16 x 3/4"	-
25	15-00301	3	Flat Washer, 3/8"	-
26	27-19512	1	Tube Assembly	-
27	35-11000	1	Thermostat, 180°F/ 82°C	-
	35-11007	1	Thermostat, 190°F/ 88°C	-
28	11-10015	2	Seal Ring	-
29	35-11004	1	Clamp	-
30	12-00223	2	Capscrew, Hex Head, 5/16-18 x 3/4" S/S	-
31	15-00222	2	Lock Washer, Helical 5/16" S/S	-
32	15-11000	2	Flat Washer, 5/16 USS S/S	-
33	10-11024	1	Cover	-
34	11-11013	1	Gasket	-
35	12-00212	4	Capscrew, Hex Head 5/16-18 x 1"	-
36	15-00202	4	Lock Washer, Helical 5/16	-
37	41-01013	30"	Hose, 5/16" I.D., Polyvinyl	-
38	00-00006	1	Nameplate "Northern Lights"	-

**As required

Heat Exchanger

L-M1064D, M1064T1-T2, M40C2, M55C2, & M65C2

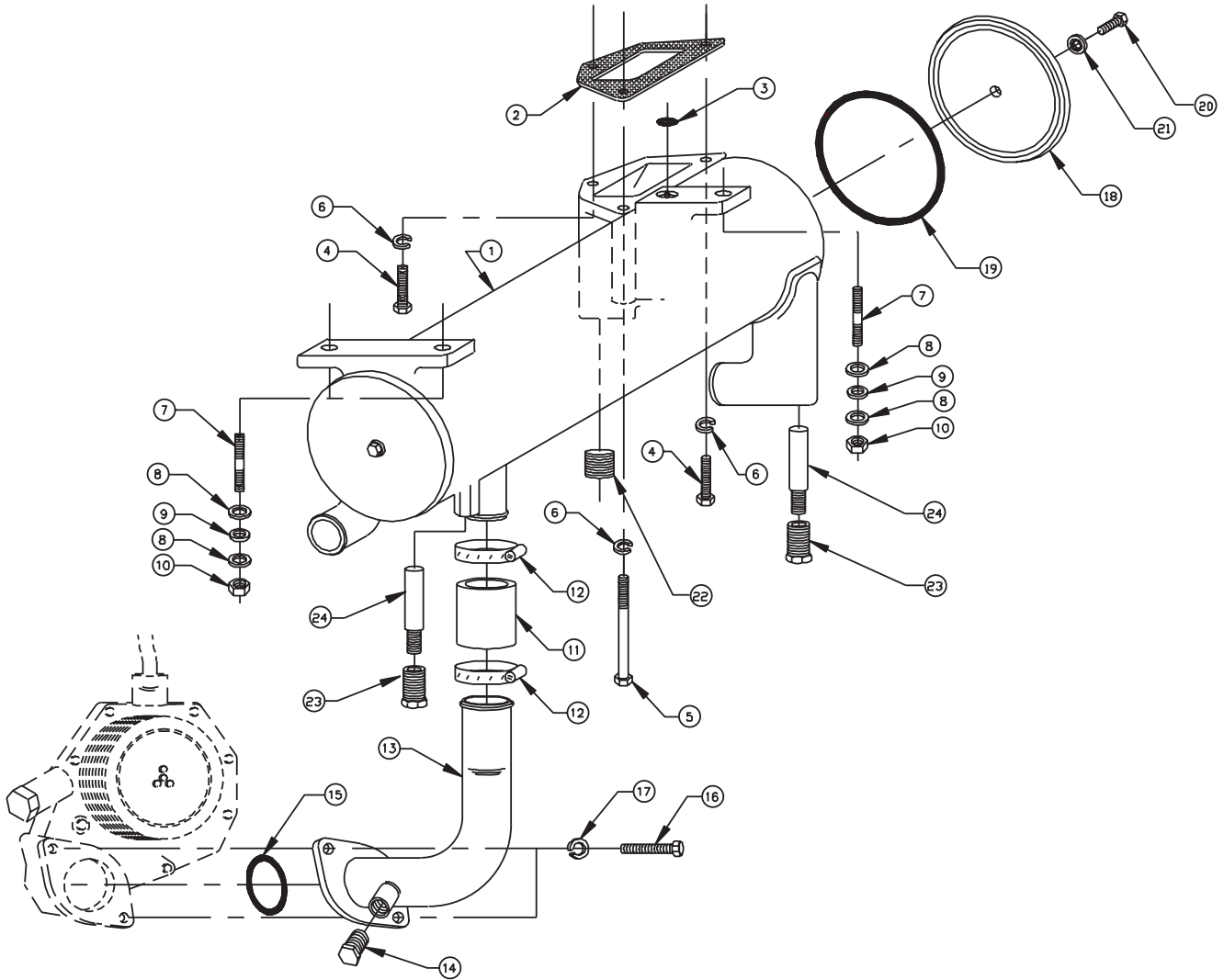

Heat Exchanger

L-M1064D, M1064T1-T2, M40C2, M55C2, & M65C2

KEY	PART NUMBER	QTY	DESCRIPTION	SERIAL NUMBER
1	20-19501	1	Heat Exchanger Assembly (Includes keys #18-24)	-
2	11-11043	1	Gasket	-
3	16-19502	1	O-ring	-
4	12-00313	2	Capscrew, Hex Head, 3/8-16 x 1-1/4"	-
5	12-00340	1	Capscrew, Hex Head, 3/8-16 x 4"	-
6	15-00302	3	Lock Washer, Helical 3/8	-
7	13-00335	3	Stud, 3/8-16 x 3/8-24 x 1-1/4"	-
8	15-70007	6	Snubbing Washer	-
9	15-19504	3	Neoprene Washer	-
10	14-00322	3	Hex Nut, Nylock 3/8-24	-
11	18-62520	1	Hose, 1-3/4" I.D. x 2-1/4"	-
12	19-01028	2	Hose Clamp #28	-
13	27-11035	1	Tube, Coolant Pump Inlet	-
14	21-00530	**	Plug, Hex Head, Brass, 1/2 NPT	-
15	16-14804	1	O-ring	-
16	12-00753	2	Capscrew, Hex Head, M8 x 1.25 x 30 mm	-
17	15-00702	2	Lock Washer, Helical M8	-
18	20-19502	2	End Cover	-
19	16-19501	2	O-ring	-
20	12-09312	2	Capscrew, Hex Head, 3/8-16 x 1" S.S.	-
21	15-19501	2	Sealing Washer	-
22	21-51905	**	Plug, Socket Head, 1" NPT	-
23	21-10000	2	Zinc Plug	-
24	21-10010	2	Zinc Electrode	-

**As required

Heat Exchanger

L- M1064A & M1064H

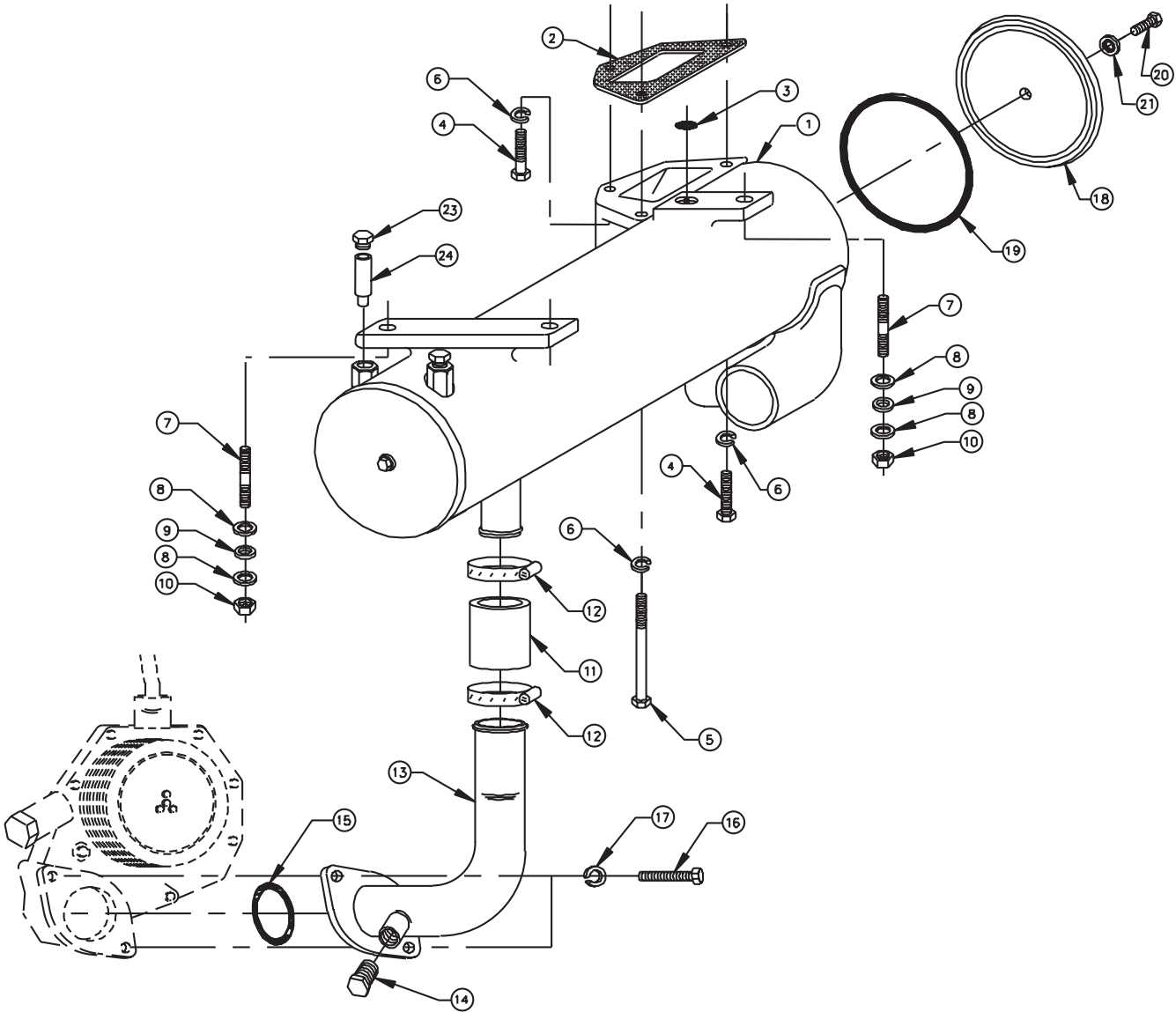

A-10162, A-10429/ C-5531

Heat Exchanger

L- M1064A & M1064H

KEY	PART NUMBER	QTY	DESCRIPTION	SERIAL NUMBER
1	20-19504	1	Heat Exchanger Assembly (Includes keys #18-24)	-
2	11-11043	1	Gasket	-
3	16-19502	1	O-ring	-
4	12-00313	2	Capscrew, Hex Head, 3/8-16 x 1-1/4"	-
5	12-00340	1	Capscrew, Hex Head, 3/8-16 x 4"	-
6	15-00302	3	Lock Washer, Helical 3/8	-
7	13-00335	3	Stud, 3/8-16 x 3/8-24 x 1-1/4"	-
8	15-70007	6	Snubbing Washer	-
9	15-19504	3	Neoprene Washer	-
10	14-00322	3	Hex Nut, Nylock 3/8-24	-
11	18-62520	1	Hose, 1-3/4" I.D. x 2-1/4"	-
12	19-01028	2	Hose Clamp #28	-
13	27-19513	1	Tube, Coolant Pump Inlet (L- M1064A)	-
	27-19511	1	Tube, Coolant Pump Inlet (M1064H)	-
14	21-00530	1	Plug, Hex Head, Brass, 1/2 NPT	-
15	16-14804	1	O-ring	-
16	12-00753	2	Capscrew, Hex Head, M8 x 1.25 x 30 mm	-
17	15-00702	2	Lock Washer, Helical M8	-
18	20-19502	2	End Cover	-
19	16-19501	2	O-ring	-
20	12-09312	2	Capscrew, Hex Head, 3/8-16 x 1" S.S.	-
21	15-19501	2	Sealing Washer	-
22	21-51905	**	Plug, Socket Head, 1" NPT	-
23	21-10000	2	Zinc Plug	-
24	21-10010	2	Zinc Electrode	-
			**As required	

GROUP 3 - COOLING SYSTEM

Coolant Pump Inlet

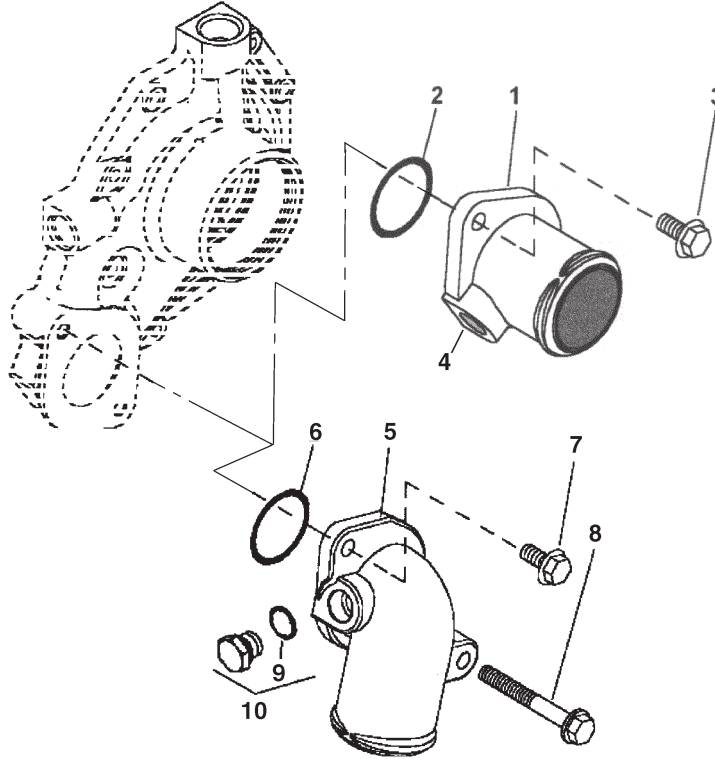

Reproduced by permission of Deere & Co., c2006. Deere & Company. All rights reserved.

RGP7821&6248

KEY	PART NUMBER	QTY	DESCRIPTION	SERIAL NUMBER
1	27-19506	1	Inlet Adapter, 2-1/4" Hose Barb (M1064D, T1, & T2)	-
	27-19507	1	Inlet Adapter, 2- 3/8" Hose Barb (L1064D)	-
	R121634	1	Inlet Adapter, 2" Hose Barb (NL1064D, T1, & T2)	-
2	16-14804	1	O-ring	-
3	19M7867	2	Capscrew, M8 x 25 mm	-
4	21-13101	**	Plug, 1/2" NPT	-
			**As required	
			For NL1064H1 and H2	
5	R502983	1	Housing	-
6	R89944	1	O-ring	-
7	19M7867	1	Screw, M8 x 25 mm	-
8	19M7802	1	Screw, M8 x 65 mm	-
9	51M7043	1	O-ring	-
10	RE46685	1	Plug	-

Coolant Pump

L- M1064D, M1064T1,T2, L- M1064A, & NL1064H1, M40C2, M55C2, M65C2

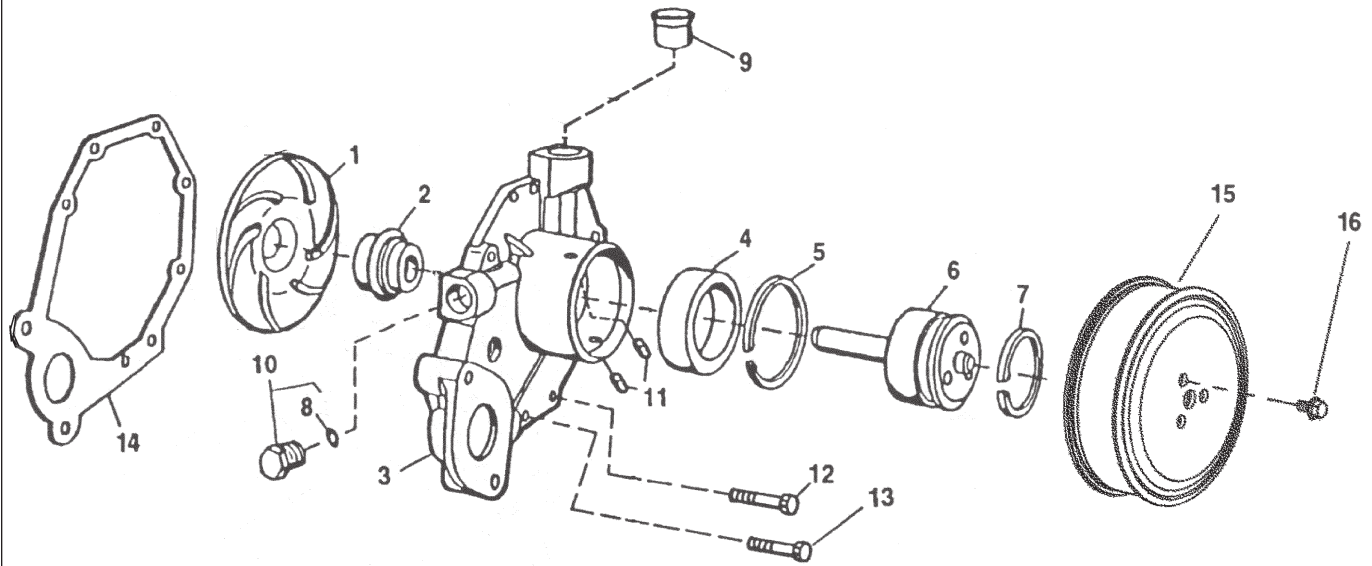

Reproduced by permission of Deere & Co., c2005. Deere & Company. All rights reserved.

TP50847 & RGP6114

KEY	PART NUMBER	QTY	DESCRIPTION	SERIAL NUMBER
••	RE505981	1	Coolant Pump, Cast Iron (marked R503509, includes keys 1-11)	-
•	RE515314	1	Repair Kit (includes keys 1-2, 4-9 & 11)	-
1			Impeller*	-
2			Seal*	-
3			Housing*	-
4			Ball Bearing*	-
5			Ring*	-
6			Shaft*	-
7	A364R	1	Snap Ring	-
8	51M7043	1	O-ring	-
9	R123226	1	Gasket	-
10	RE46685	1	Plug	-
11	R100369	2	Filter	-
12	19M7863	5	Capscrew, M6 x 25	-
13	19M7796	3	Capscrew, M6 x 30	-
14	R123417	1	Gasket	-
15	R121038	1	Pulley, 112 mm OD	-
16	19M7784	1	Capscrew, Flanged Head M6 x 1.0 x 12 mm	-
17	RE508566	1	Timing Cover Insert Kit (not shown)	-
			*Not available separately - order Pump Repair Kit or Coolant Pump Assembly	

GROUP 3 - COOLING SYSTEM

Coolant Pump

M1064H & NL1064H2

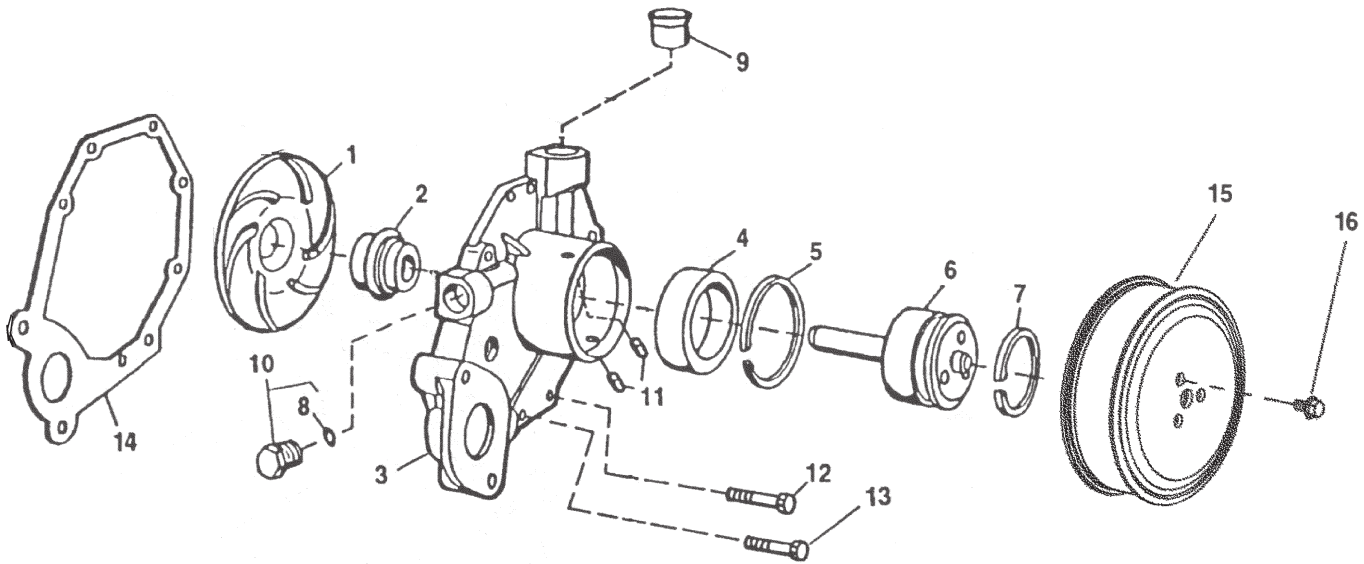

Reproduced by permission of Deere & Co., c2005. Deere & Company. All rights reserved.

TP50847 & RGP6114

KEY	PART NUMBER	QTY	DESCRIPTION	SERIAL NUMBER
••	RE505980	1	Coolant Pump, Cast Iron (marked R503509, includes keys 1-11)	-
•	RE509813	1	Repair Kit (includes keys 1-2, 4-9 & 11)	-
1			Impeller*	-
2			Seal*	-
3			Housing*	-
4			Ball Bearing*	-
5			Ring*	-
6			Shaft*	-
7	A364R	1	Snap Ring	-
8	51M7043	1	O-ring	-
9	R123226	1	Gasket	-
10	RE46685	1	Plug	-
11	R100369	2	Filter	-
12	19M7863	5	Capscrew, M6 x 25	-
13	19M7796	3	Capscrew, M6 x 30	-
14	R123417	1	Gasket	-
15	R115250	1	Pulley, 93 mm OD	-
16	19M7774	1	Capscrew, Flanged Head M6 x 1.0 x 12 mm	-
17	RE508566	1	Timing Cover Insert Kit (not shown)	-
			*Not available separately - order Pump Repair Kit or Coolant Pump Assembly	

Raw Water Pump and Mounting

L- M1064D, M1064T1- T2, M40C2, M55C2, & M65C2

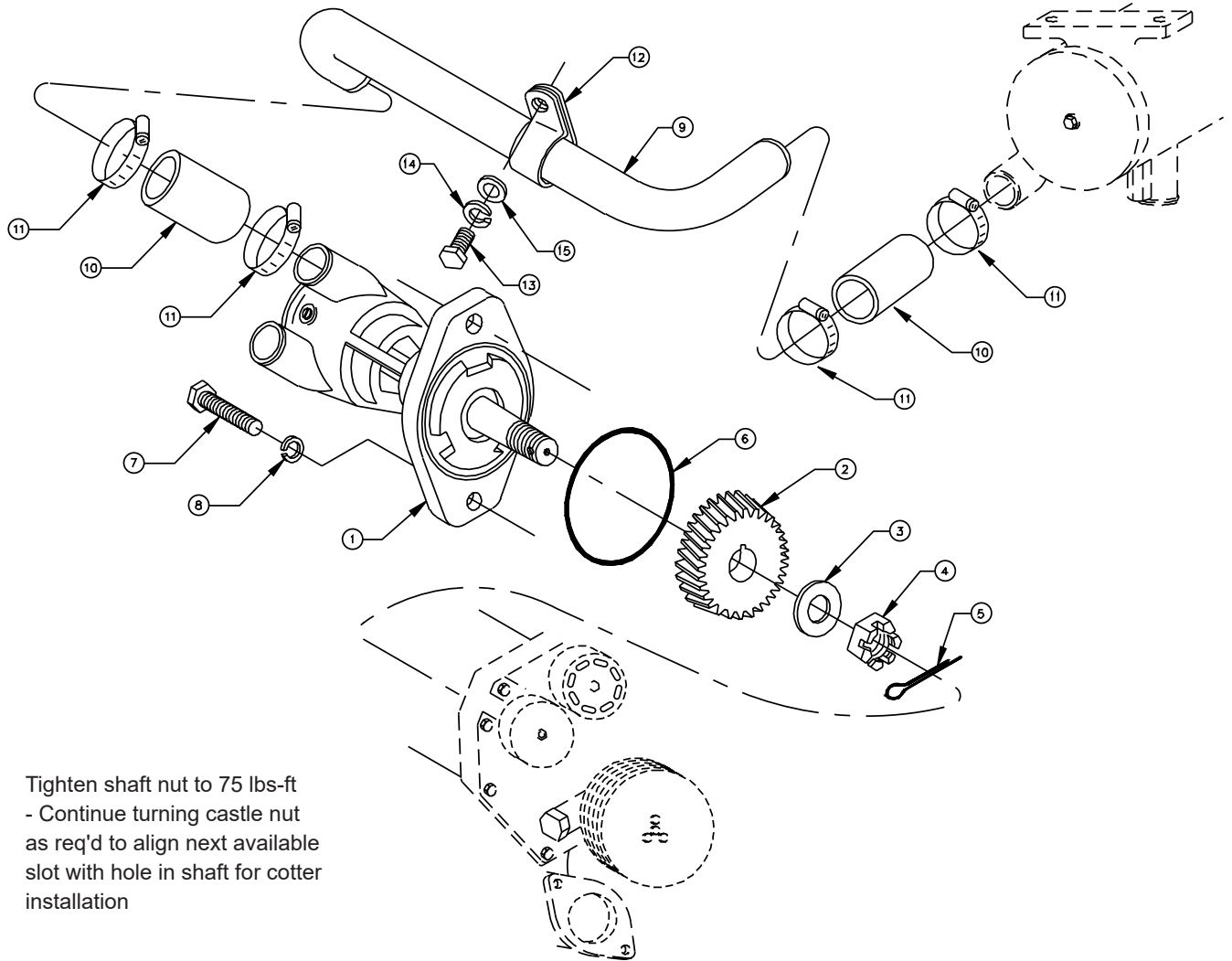

Tighten shaft nut to 75 lbs-ft
 - Continue turning castle nut
 as req'd to align next available
 slot with hole in shaft for cotter
 installation

A-8362/ C-4177

KEY	PART NUMBER	QTY	DESCRIPTION	SERIAL NUMBER
1	25-19501	1	Raw Water Pump (see Parts detail)	-
2	R135101	1	Gear	-
3	15-19503	1	Shaft Flat Washer	-
4	14-19501	1	Hex Nut, Slotted	-
5	32-00005	1	Cotter Pin	-
6	16-19503	1	O-ring	-
7	12-00954	2	Capscrew, Hex Head M12 x 1.75 x 35 mm	-
8	15-00912	2	Lock Washer, Helical M12	-
9	27-19502	1	Tube	-
10	18-19501	2	Hose, 1-1/4" I.D. x 2- 1/2"	-
11	19-01020	4	Hose Clamp #20	-
12	19-71031	1	Adelle Clamp	-
13	12-00805	1	Capscrew, Hex Head M10 x 1.5 x 20 mm	-
14	15-00802	1	Lock Washer, Helical M10	-
15	15-00805	1	Flat Washer, M10	-

GROUP 3 - COOLING SYSTEM

Raw Water Pump and Mounting

L- M1064A & M1064H

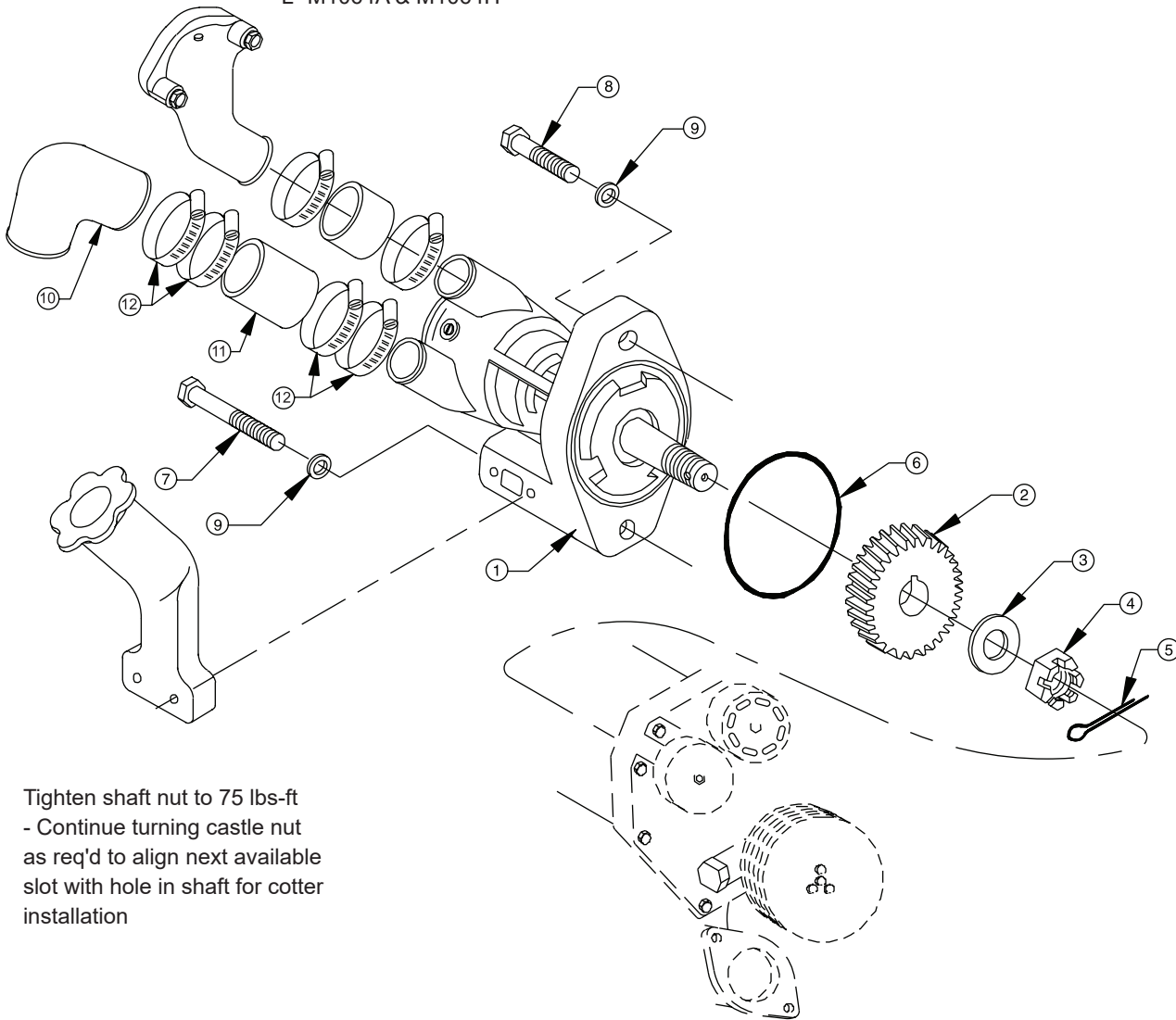

A-10161/ C-5450

KEY	PART NUMBER	QTY	DESCRIPTION	SERIAL NUMBER
1	25-19522	1	Raw Water Pump Assembly (See Parts Detail)	-
2	R135101	1	Gear	-
3	15-19503	1	Shaft Flat Washer	-
4	14-19501	1	Hex Nut, Slotted	-
5	32-00005	1	Cotter Pin	-
6	16-19503	1	O-ring	-
7	12-00922	1	Capscrew, Hex Head, M12 x 1.75 x 90 mm	-
8	12-00956	1	Capscrew, Hex Head, M12 x 1.75 x 65 mm	-
9	15-00007	2	Flat Washer M12	-
10	21-19504	1	Connector	-
11	41-01112	3	Hose 2" I.D. Silicone	-
12	19-01032	4	Hose Clamp, #32 Extended Band	-

Raw Water Pump Assembly

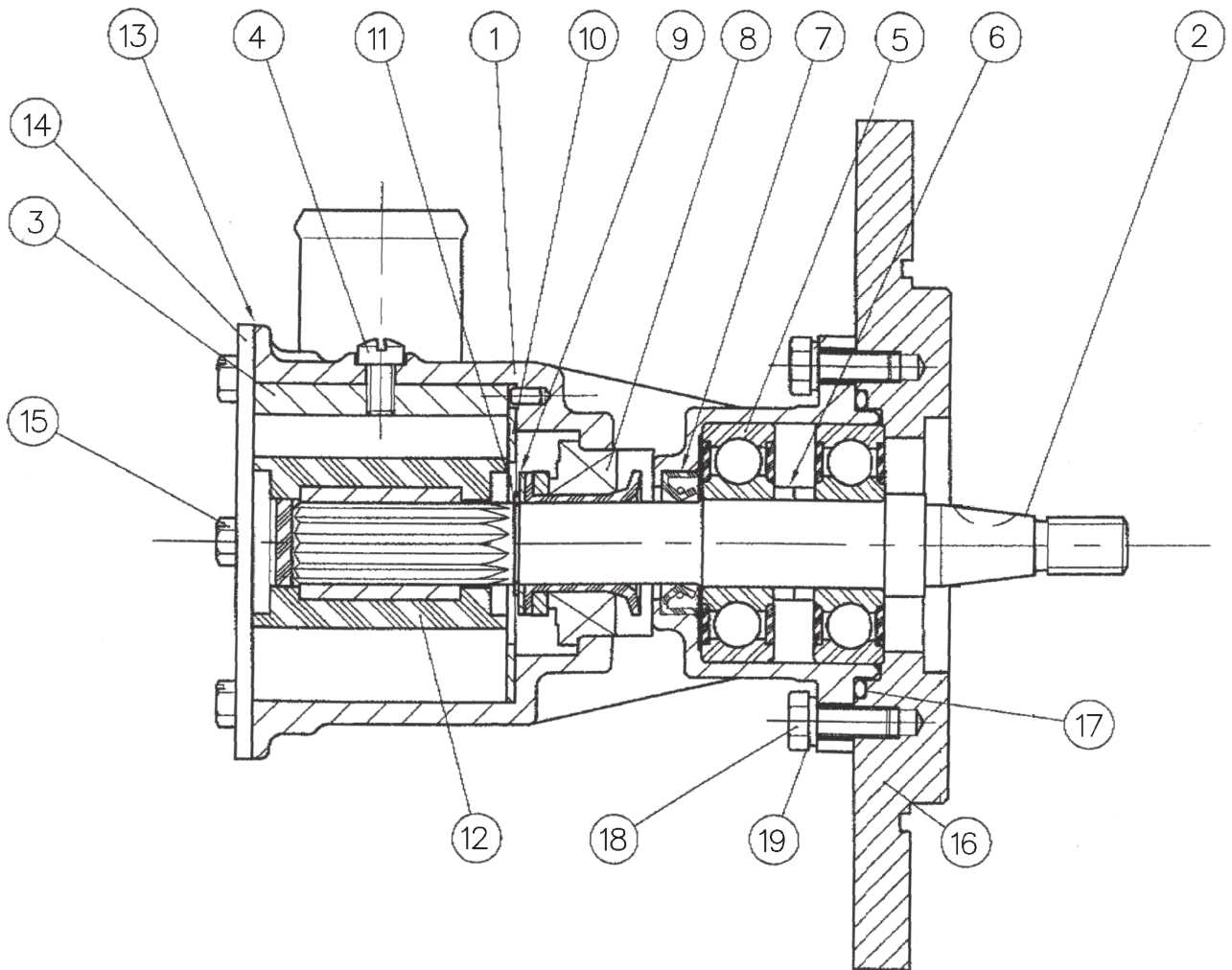

KEY	PART NUMBER	QTY	DESCRIPTION	SERIAL NUMBER
••	25-19501	1	Raw Water Pump Assembly (Includes all keys)	-
1	25-19502	1	Housing	-
2	25-19503	1	Shaft	-
3	25-11621	1	Cam	-
4	25-11619	1	Screw	-
5	25-19504	2	Bearing	-
6	25-19506	2	Spacer	-
7	25-19507	1	Seal, Lip Type	-
8	25-19508	1	Seal, Mechanical/ Carbon	-
9	25-19509	1	Support Washer	-
10	25-19511	1	Wear Plate	-
11	25-19512	1	Snap Ring	-
12	25-11011	1	Impeller with Gasket	-
13	25-11017	1	Gasket	-
14	25-19513	1	Cover	-
15	25-19514	6	Capscrew	-
16	25-19516	1	Flange	-
17	25-19517	1	O-ring	-
18	12-00776	3	Capscrew, Hex Head M8 x 1.25 x 20 mm S/S	-
19	15-00705	3	Lock Washer, Helical M8 S/S	-

GROUP 3 - COOLING SYSTEM

Raw Water Pump Assembly

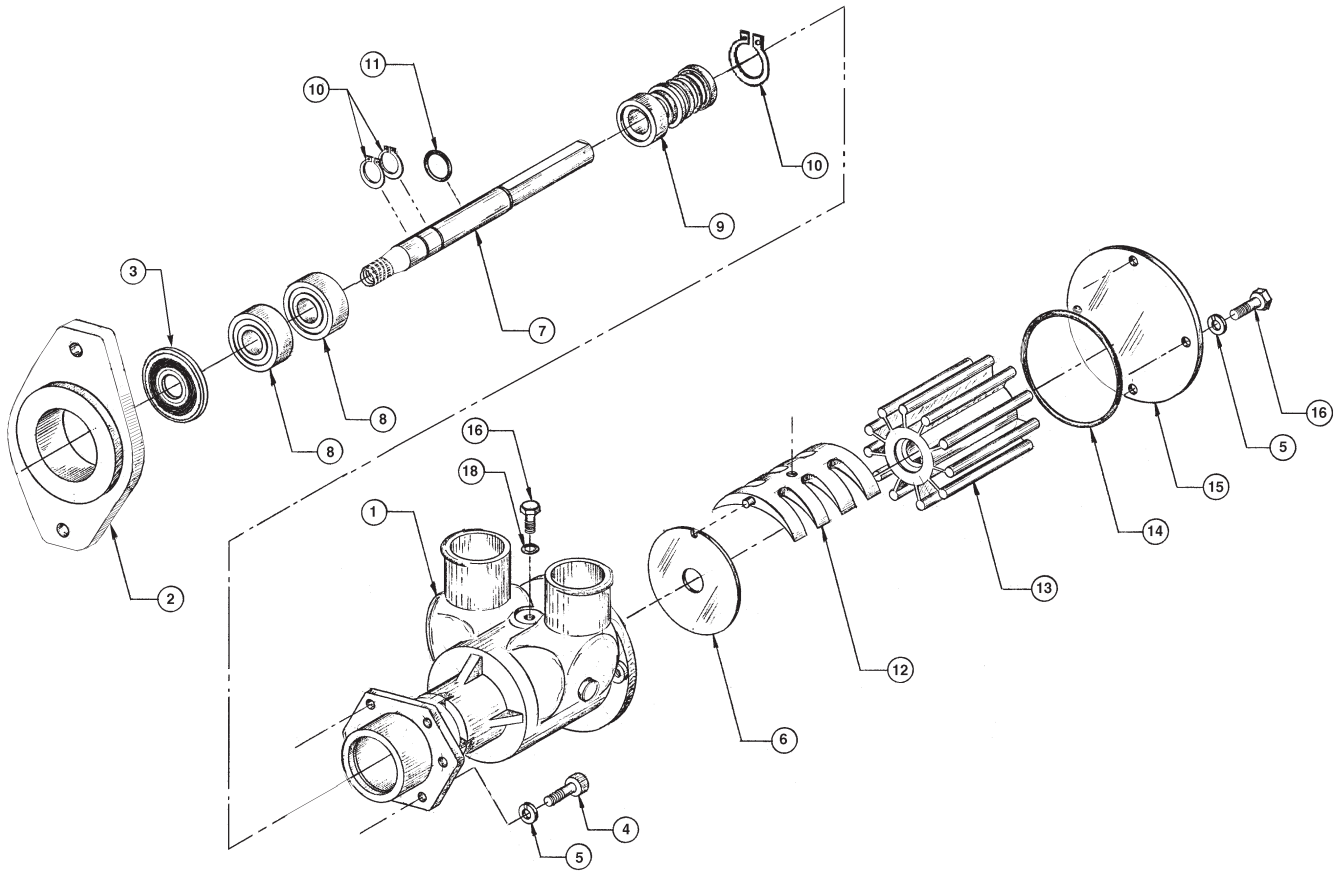

A-10161/ D-2259A

KEY	PART NUMBER	QTY	DESCRIPTION	SERIAL NUMBER
●●	25-19522	1	Raw Water Pump Assembly (Includes all keys)	-
1	25-19502	1	Housing	-
2	31-19501	1	Adapter	-
3	25-19521	1	Oil Seal	-
4	25-15717	6	Capscrew, Socket Head M6 x 1.0 x 25 mm S/S	-
5	15-00610	10	Lock Washer, M6 S/S	-
6	25-15706	1	Wear Plate	-
7	25-19524	1	Shaft	-
8	25-15708	2	Bearing	-
9	25-19526	1	Mechanical Seal	-
10	25-15716	3	Snap Ring	-
11	25-15713	1	O-ring	-
12	25-15703	1	Cam	-
13	25-15704	1	Impeller	-
14	25-15711	1	O-ring	-
15	25-19523	1	End Cover	-
16	25-15718	5	Capscrew, Socket Head M6 x 1.0 x 16 mm S/S	-
18	25-15714	1	O-ring	-

Thermostat Housing Assembly

NL1064D, T1, T2, & H1

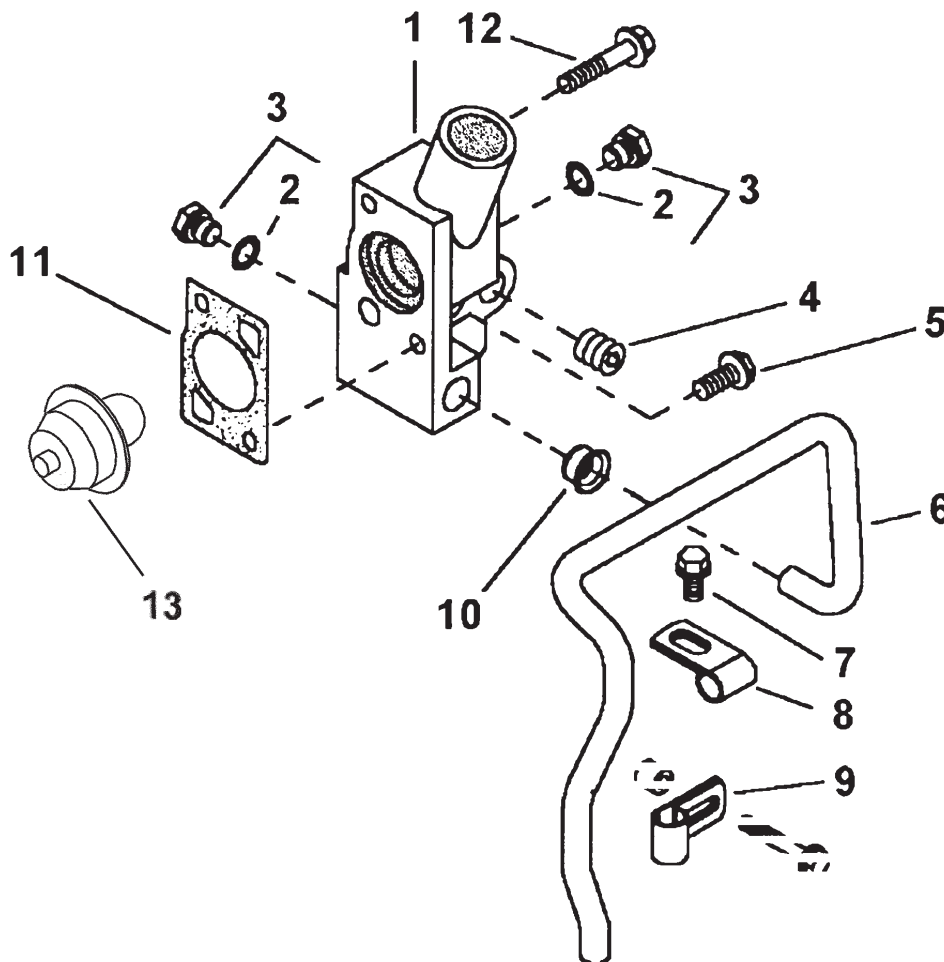

Reproduced by permission of Deere & Co., c2005. Deere & Company. All rights reserved.

RGP9832

KEY	PART NUMBER	QTY	DESCRIPTION	SERIAL NUMBER
1	R501556	1	Cover	-
2	51M7041	2	O-ring	-
3	RE46684	**	Plug	-
4	15H624	**	Pipe Plug 1/2"	-
5	19M7786	1	Capscrew, M10 x 30	-
6	R123629	1	Tube	-
7	19M7788	1	Screw, M12 x 25	-
8	R123323	1	Clamp, Cylinder Head	-
9	R123324	1	Clamp, Timing Gear Cover	-
10	R123226	1	Seal	-
11	R502814	1	Gasket	-
12	19M7809	1	Screw, M10 x 70	-
13	RE522076	1	Thermostat 180°F/ 82°C (formerly #RE506300)	-
			**As required	

GROUP 3 - COOLING SYSTEM

Thermostat Housing Assembly

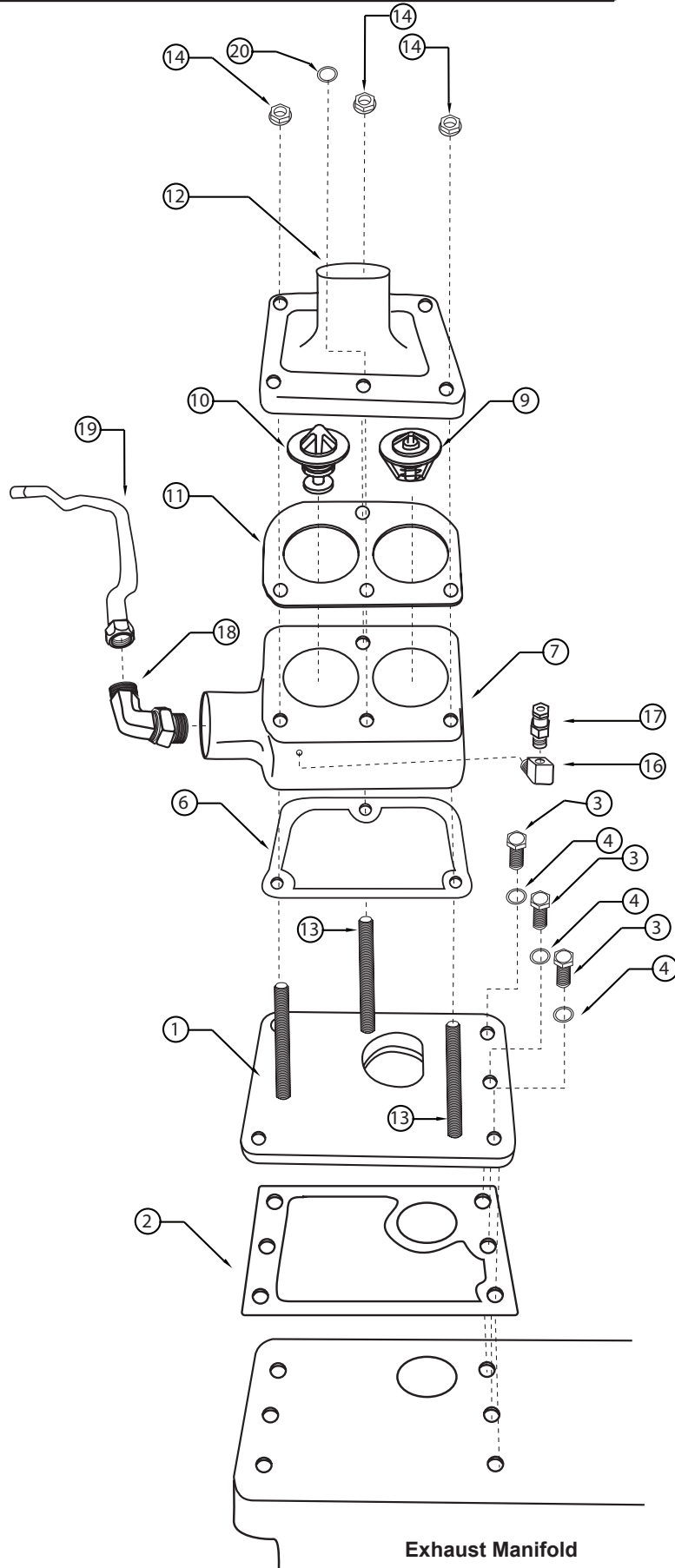

10-19400_drawing

Thermostat Housing Assembly

KEY	PART NUMBER	QTY	DESCRIPTION	SERIAL NUMBER
1	31-19512	1	Adapter, Thermostat Housing	-
2	11-11023	1	Gasket, Manifold to Expansion Tank	-
3	12-00313	6	Capscrew, Hex Head 3/8"-16 X 1-1/4"	-
4	15-00302	6	Lock Washer, Helical 3/8"	-
5	15-00321	3	Flat Washer 3/8" SAE	-
6	R116205	1	Gasket	-
7	10-19503	1	Thermostat Housing	-
8	21-13101	1	Plug Socket Head 1/2 NPT	-
9	RE33705	1	Thermostat 180F/82C	-
10	AR102258	1	Thermostat	-
11	R133142	1	Gasket	-
12	10-19506	1	Thermostat Cover, Vertical Outlet	-
13	13-00832	3	Stud M10 x 1.5 x 125mm LOA	-
14	14-80811	3	Hex Nut, Flanged	-
15	21-00132	1	Bushing 1/4 NPT x 1/8 NPT	-
16	21-72044	1	Street Elbow 90° Brass 1/8 NPT	-
17	21-10001	1	Drain Cock	-
18	21-64803	1	M.Elbow 90, Stl.	-
19	27-19519	1	Tube Assembly	-
20	15-00300	3	Flat Washer M10 Small OD	-

Thermostat Housing Assembly

NL1064H2

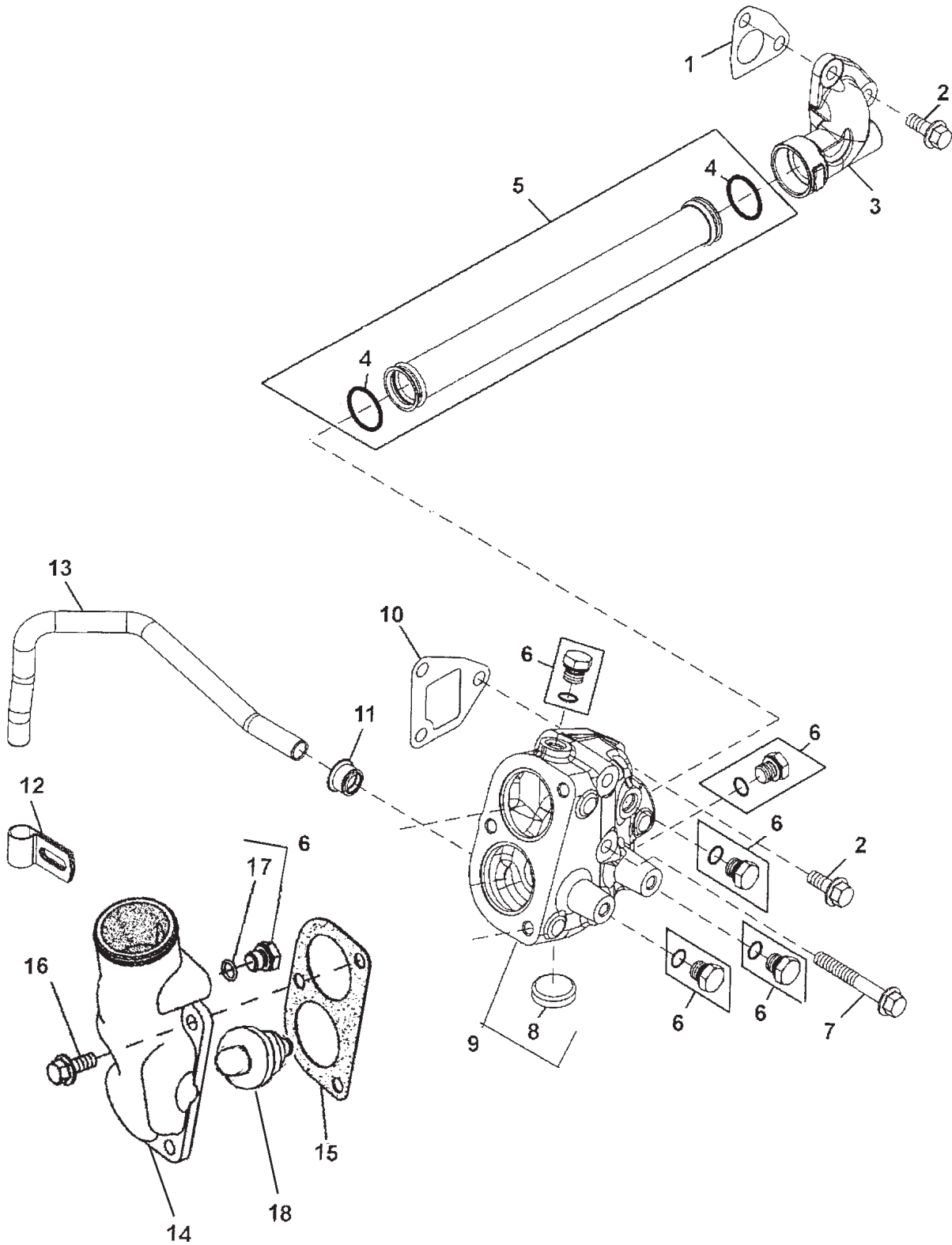

Thermostat Housing Assembly

NL1064H2

KEY	PART NUMBER	QTY	DESCRIPTION	SERIAL NUMBER
1	R505480	1	Gasket	-
2		**	Capscrew	-
3	R504754	1	Manifold	-
4	R63185	2	O-ring	-
5	RE516026	1	Tube	-
6	RE46684	**	Plug (includes key #17)	-
7	19M7810	2	Capscrew, M10 x 80	-
8	CD16284	1	Plug	-
9	RE517057	1	Housing (marked R515580)	-
10	R505479	1	Gasket	-
11	R123226	1	Seal	-
12	R123324	1	Clamp	-
13	R504854	1	Tube	-
14	R515581	1	Cover, M8 x 45	-
15	R124607	1	Gasket	-
16	19M7785	1	Capscrew, M10 x 25	-
17	51M7041	**	O-ring	-
18	AR48675	1	Thermostat, 180°F (82°C)	-
	RE33705	1	Thermostat, 180°F (82°C)	-
			**As required	

GROUP 3 - COOLING SYSTEM

Engine Oil Cooler

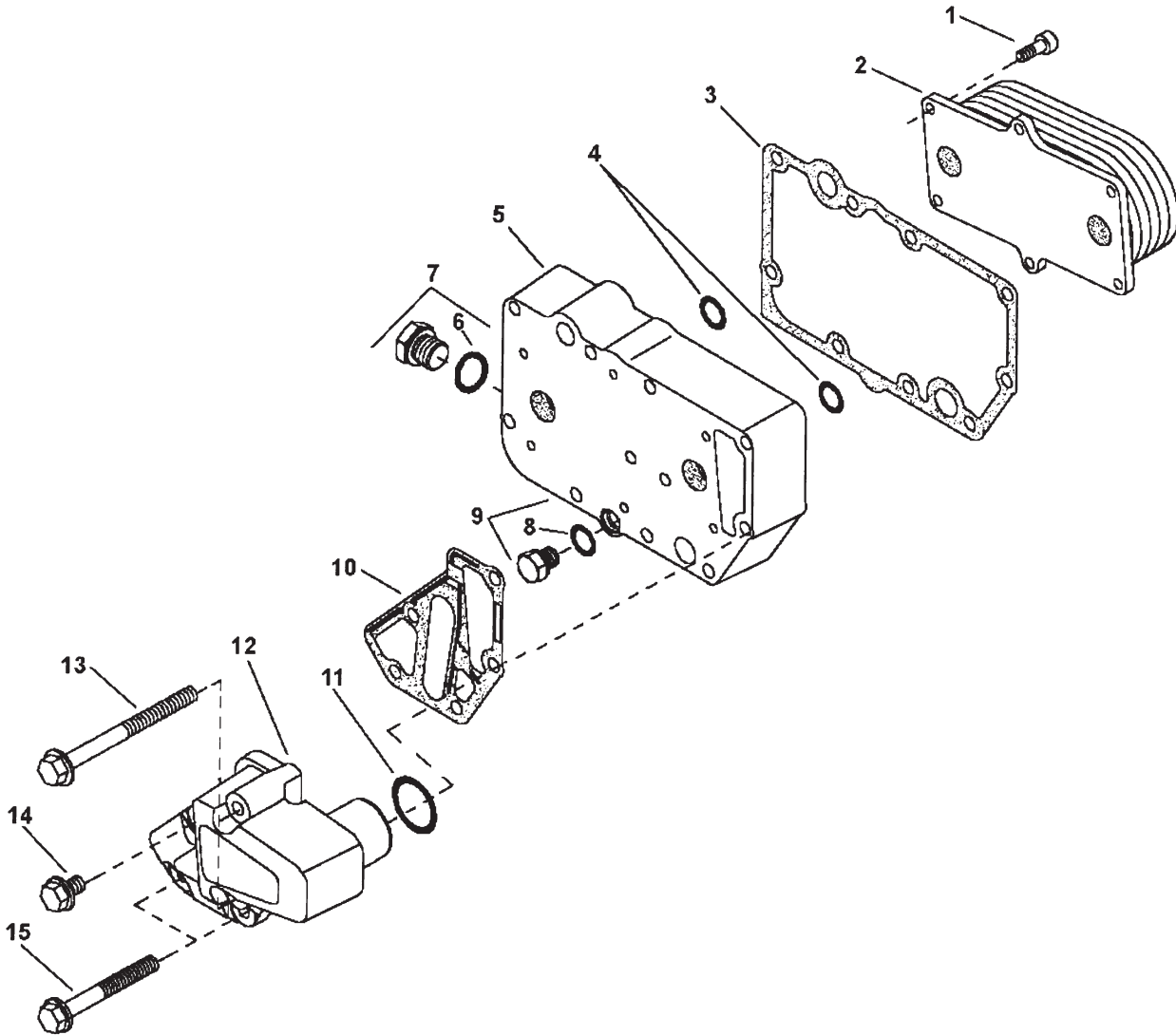

Reproduced by permission of Deere & Co., c2005. Deere & Company. All rights reserved.

RGP8307

KEY	PART NUMBER	QTY	DESCRIPTION	SERIAL NUMBER
2	RE59812	1	Oil Cooler L-M-NL1064D	-
	RE59296	1	Oil Cooler L-M-NL1064T1-T2-A & NL1064H1	-
	RE56690	1	Oil Cooler M1064H & NL1064H2	-
2	RE67231	6	Capscrew, M6 x 16	-
3	R123501	1	Gasket	-
4	T122075	2	O-ring	-
5	R123471	1	Housing	-
6	51M7043	1	O-ring	-
7	RE46685	1	Plug	-
8	51M7040	1	O-ring	-
9	RE46686	1	Plug	-
10	R501428	1	Gasket	-
11	R504734	1	O-ring	-
12	R502811	1	Adapter	-
13	19M7970	2	Capscrew, M8 x 100	-
14	RE67238	1	Capscrew, M8 x 20	-
15	19M7802	2	Capscrew, M8 x 65	-

Idler Shaft Assembly

L-M-NL1064D, M1064T1, T2, & A, M40C2, M55C2, M65C2 & M1064T2MCA

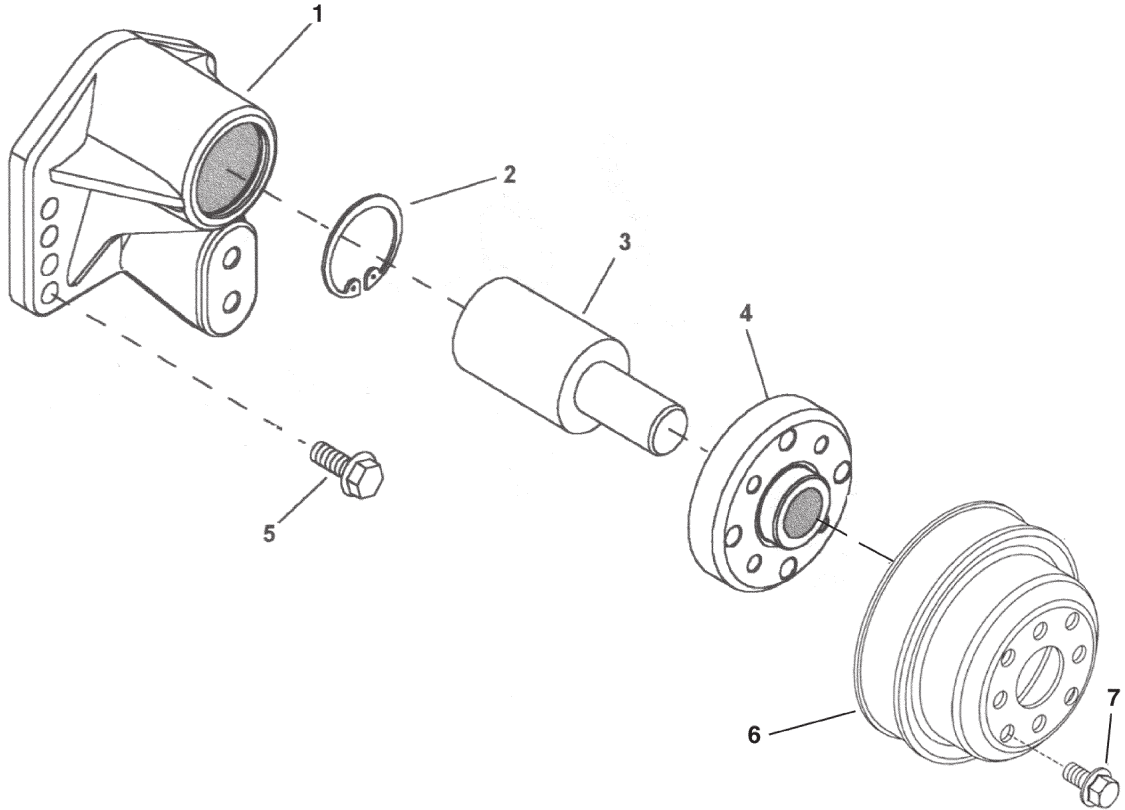

Reproduced by permission of Deere & Co., c2005. Deere & Company. All rights reserved.

RGP6123 & RGP6278

KEY	PART NUMBER	QTY	DESCRIPTION	SERIAL NUMBER
1	RE500539	1	Idler Shaft (includes keys #2-4, marked R500304)	-
	RE500538	1	Idler Shaft (M1064T2MCA only)	-
2	H80753	1	Snap Ring	-
3		1	Bearing*	-
4		1	Hub*	-
5	19M7835	4	Capscrew, Hex Head Flanged M10 x 1.5 x 35 mm	-
6	R128660	1	Pulley, 168 mm O.D.	-
	R128658	1	Pulley, 140 mm O.D. (NL1064D & M1064T2MCA)	-
7	19M7784	4	Capscrew, Hex Head Flanged M10 x 1.5 x 20 mm	-
*No longer available separately - order complete Idler Shaft assembly.				

Idler Shaft Assembly

NL1064T1, T2, & H1

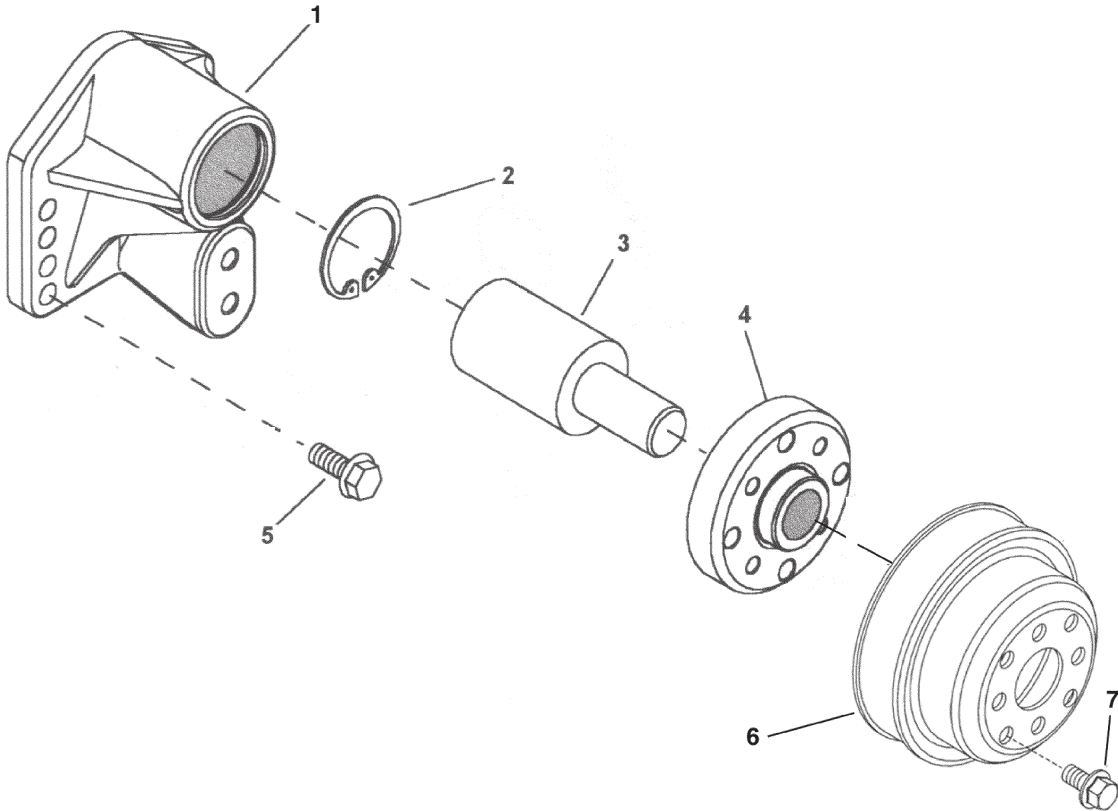

Reproduced by permission of Deere & Co., c2005. Deere & Company. All rights reserved.

RGP6123 & RGP6278

KEY	PART NUMBER	QTY	DESCRIPTION	SERIAL NUMBER
1	RE500538	1	Idler Shaft (includes keys #2-4, marked R500171)	-
2	H80753	1	Snap Ring	-
3		1	Bearing*	-
4		1	Hub*	-
5	19M7835	4	Capscrew, Hex Head Flanged M10 x 1.5 x 35 mm	-
6	R128660	1	Pulley, 168 mm O.D.	-
7	19M7784	4	Capscrew, Hex Head Flanged M10 x 1.5 x 20 mm	-
*No longer available separately - order complete Idler Shaft assembly.				

Idler Shaft Assembly

M1064H - NL1064H2

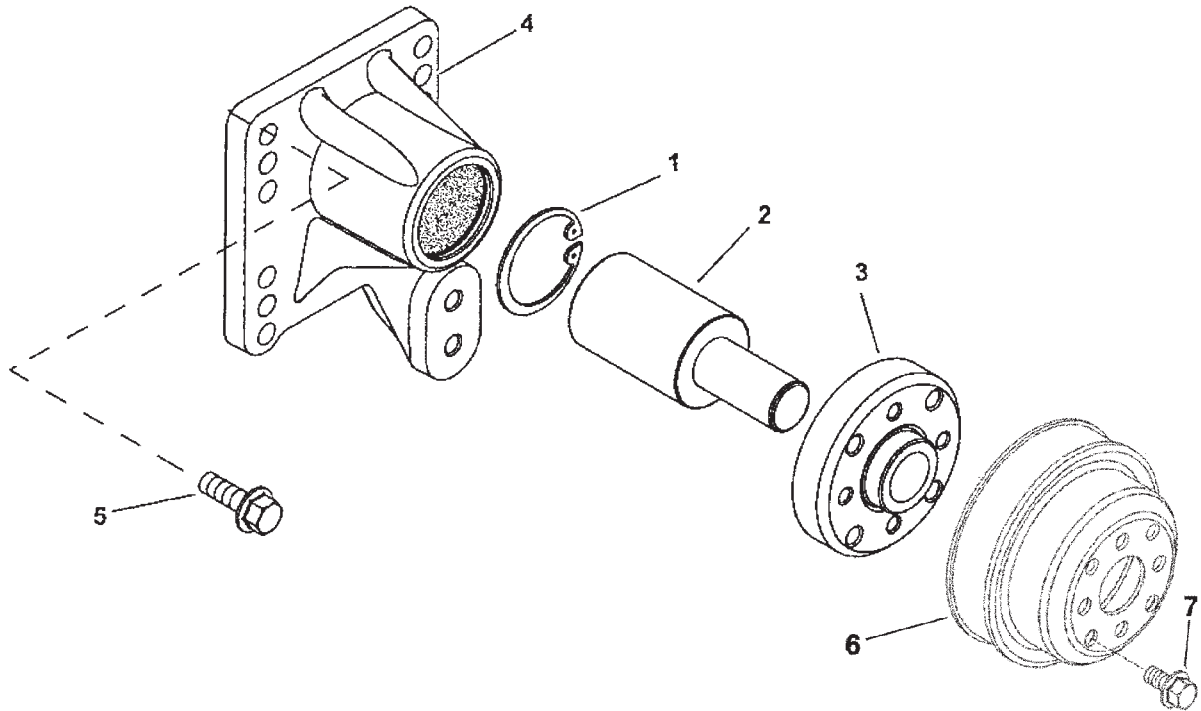

Reproduced by permission of Deere & Co., c2005. Deere & Company. All rights reserved.

RGP9065

KEY	PART NUMBER	QTY	DESCRIPTION	SERIAL NUMBER
1	RE503664	1	Idler Shaft (includes keys #2-4)	-
2	E1343FN	1	Snap Ring	-
3		1	Shaft*	-
4		1	Hub*	-
5	19M7786	4	Capscrew, Hex Head Flanged M10 x 1.5 x 30 mm	-
6	R128660	1	Pulley, 168 mm O.D. (M1064H @ 1500 & 1800 RPM - NL1064H2 @ 1800 RPM)	-
6	R128658	1	Pulley, 140 mm O.D. (NL1064H2 @ 1500 RPM)	-
7	19M7784	4	Capscrew, Hex Head Flanged M10 x 1.5 x 20 mm	-
*No longer available separately - order complete Idler Shaft assembly.				

Radiator

NL1064D

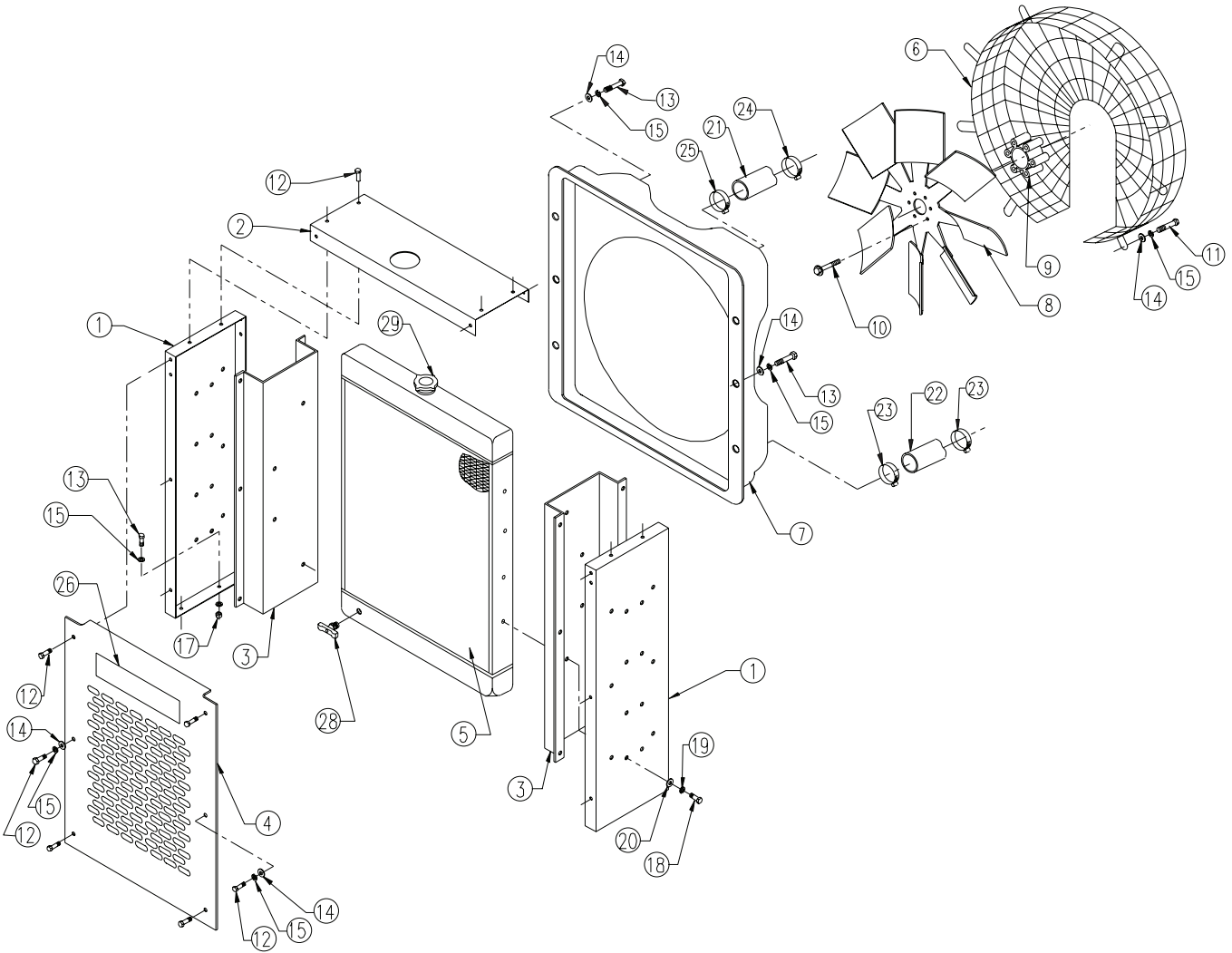

A-7614/ C-5780

Radiator

NL1064D

KEY	PART NUMBER	QTY	DESCRIPTION	SERIAL NUMBER
1	39-11015	2	Side Panel	-
2	39-11016	1	Top Panel	-
3	23-11010	2	Bracket, Radiator Mtg.	-
4	39-11017	1	Grille	-
5	RE64110	1	Radiator	-
6	RE64109	1	Fan Shroud	-
7	RE64108	1	Fan Guard	-
8	RE47518	1	Fan 18" (Blower)	-
9	R128442	1	Spacer, Fan Mtg.	-
10	12-80049	4	Capscrew, Hex Head Flanged M10 x 1.5 x 80 mm	-
11	12-00312	4	Capscrew, Hex Head 3/8- 16 x 1"	-
12	12-00311	12	Capscrew, Hex Head 3/8- 16 x 3/4"	-
13	12-00362	6	Capscrew, Hex Head 3/8- 16 x 1/2"	-
14	15-00321	18	Flat Washer 3/8" SAE	-
15	15-00302	8	Lock Washer, Helical 3/8"	-
16	14-00312	12	Hex Nut, Nylock 3/8- 16"	-
17	14-00301	6	U-nut 3/8- 16"	-
18	12-00209	16	Capscrew, Hex Head 5/16- 18 x 3/4"	-
19	15-00202	20	Lock Washer, Helical 5/16"	-
20	15-00221	8	Flat Washer 5/16" SAE	-
21	R128455	1	Hose, Radiator Inlet	-
22	R128456	1	Hose, Radiator Outlet	-
23	19-00028	2	Hose Clamp #28	-
24	19-00036	1	Hose Clamp #36	-
25	19-00032	1	Hose Clamp #32	-
26	00-70082	1	Label, "Northern Lights"	-
27	41-01013	36	Hose, Polyvinyl 5/16" ID x 7/16" OD	-
28	21-10002	1	Drain Cock, Brass 1/4 NPT	-

GROUP 3 - COOLING SYSTEM

Radiator

M1064T2MCA

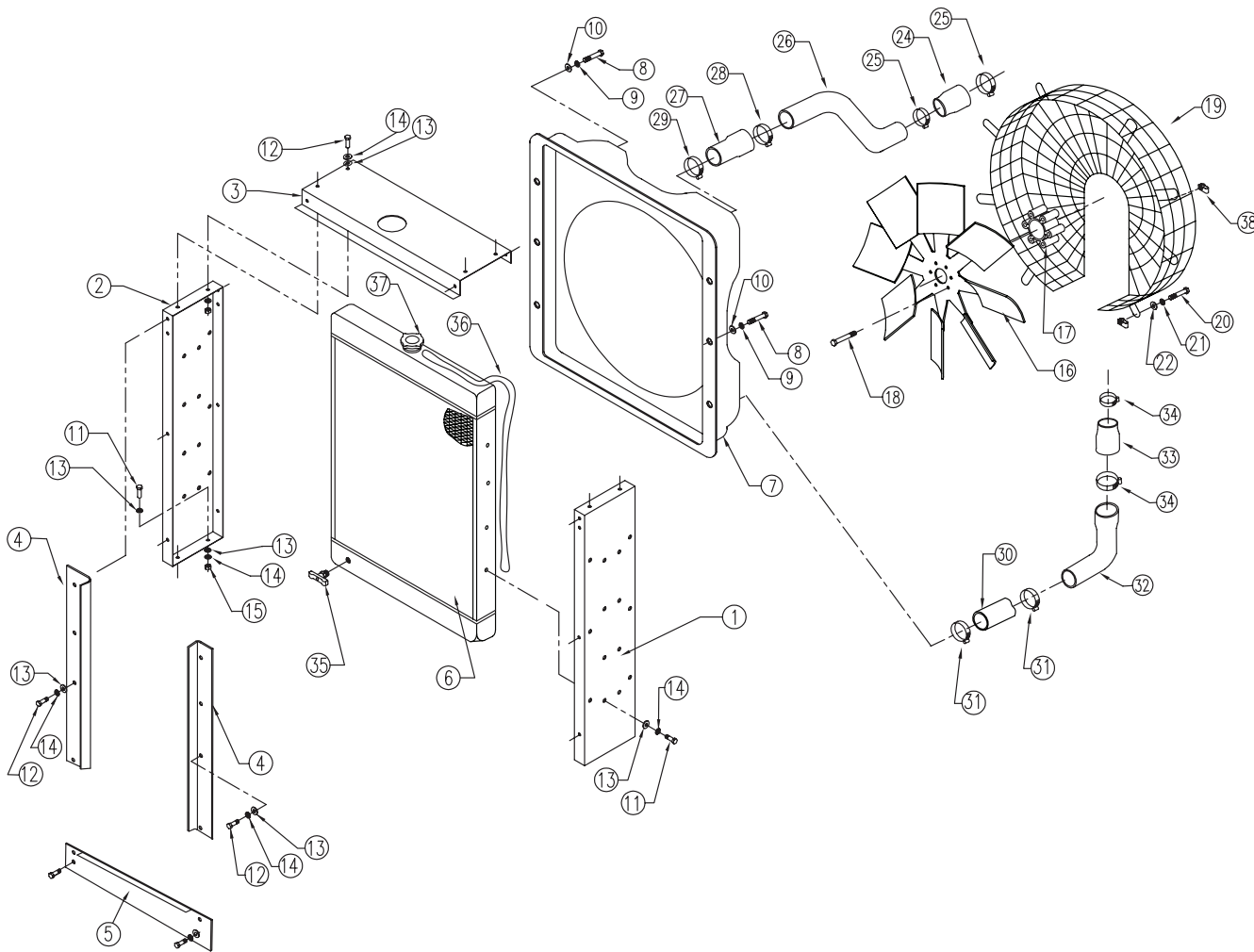

C-6780

Radiator

M1064T2MCA

KEY	PART NUMBER	QTY	DESCRIPTION	SERIAL NUMBER
1	39-19419	1	Side Panel, Modular Radiator Guard, L.H.	-
2	39-19421	1	Side Panel, Modular Radiator Guard, R.H.	-
3	39-19422	2	Top Panel, Modular Radiator Guard	-
4	39-19423	2	Duct Flange	-
5	39-19424	1	Lower Valence	-
6	20-19509	1	Radiator (Heresite Coated)	-
7	RE64114	1	Fan Shroud	-
8	12-09212	6	Capscrew, Hex Head 5/16 - 18 X 1"	-
9	15-00222	6	Lock Washer	-
10	15-11000	6	Flat Washer	-
11	12-00312	20	Capscrew, Hex Head 3/8-16 X 1"	-
12	12-00311	18	Capscrew, Hex Head 3/8-16 X 3/4"	-
13	15-00321	42	Flat Washer	-
14	15-00302	38	Lock Washer	-
15	14-00311	4	Hex Nut	-
16	AT24834	1	Fan	-
17	R128443	1	Fan Spacer 4 Bolt	-
18	19M7811	4	Capscrew, Hex Head Flanged	-
19	RE57059	1	Fan Guard	-
20	12-09213	4	Capscrew Hex Head 5/16-18 x 1 - 1/4"	-
21	15-00222	4	Lock Washer	-
22	15-70004	4	Snubbing Washer	-
23	00-70082	1	Label, "Northern Lights" 2" x 22"	-
24	18-19405	1	Hose 2-1/2"ID x 2-3/4"	-
25	19-00040	2	Hose Clamp #40	-
26	27-19407	1	Tube, Radiator Inlet	-
27	18-19402	1	Hose 1-3/4" ID x 2-3/4" X 2.72" * (Modified)	-
28	19-00036	1	Hose Clamp #36	-
29	19-00028	1	Hose Clamp #28	-
30	18-19404	1	Hose 2-1/4" ID x 3-1/2"	-
31	10-00040	2	Hose Clamp #40	-
32	27-19405	1	Tube 2" ID x 2-3/4"	-
33	18-19403	1	Hose 2" ID x 2-3/4"	-
34	19-00036	2	Hose Clamp #36	-
35	21-10002	1	Drain Cock	-
36	41-01013	36	Hose, Polyvinyl 5/16"ID x 7/16"OD	-
37	RE64092	1	Cap, Coolant Fill	-
38	19-43201	2	Adelle Clamp	-

GROUP 3 - COOLING SYSTEM

Radiator

NL1064T1 - T2

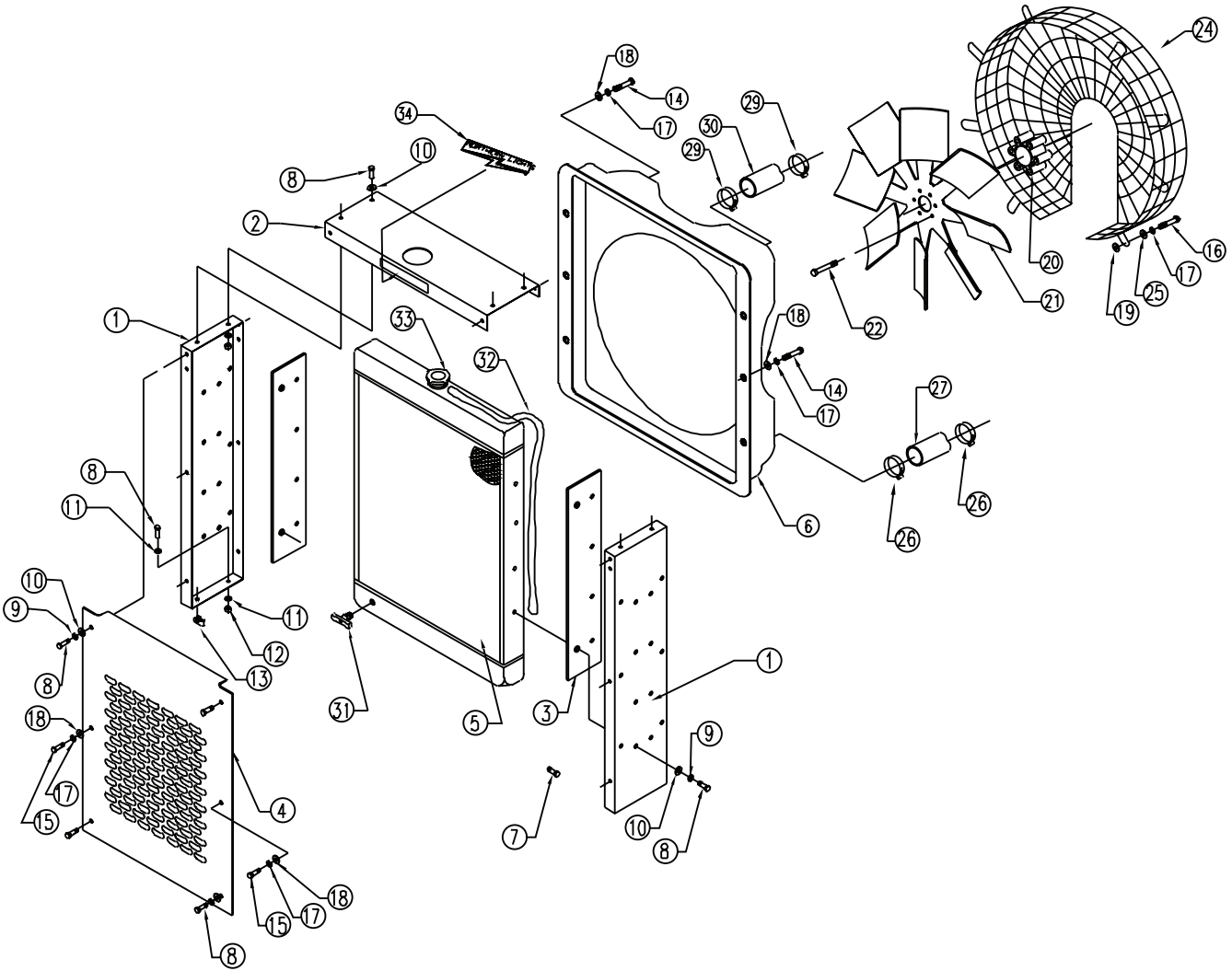

A-7615/ C-5778

Radiator

NL1064T1 - T2

KEY	PART NUMBER	QTY	DESCRIPTION	SERIAL NUMBER
1	39-11015	2	Side Panel, Modular Radiator Guard	-
2	39-11016	1	Top Panel, Modular Radiator Guard	-
3	21-11001	2	Spacer Plate, Radiator Mtg.	-
4	39-11017	1	Grille, Modular Radiator Guard	-
5	RE64112	1	Radiator	-
6	RE64114	1	Fan Shroud	-
7	12-03310	4	Capscrew, Flh Skt 3/8- 16 x 3/4"	-
8	12-00312	24	Capscrew, Hex Head 3/8- 16 x 1"	-
9	15-00321	12	Lock Washer, Helical 3/8"	-
10	12-00312	28	Flat Washer 3/8"	-
11	15-00301	8	Flat Washer 3/8"	-
12	14-00312	12	Hex Nut, Nylock 3/8- 16	-
13	14-00301	4	U-Nut 3/8- 16	-
14	12-00212	6	Capscrew, Hex Head 5/16- 18 x 1"	-
15	12-00209	2	Capscrew, Hex Head 5/16- 18 x 3/4"	-
16	12-00213	4	Capscrew, Hex Head 5/16- 18 x 1 1/4"	-
17	15-00202	12	Lock Washer, Helical 5/16	-
18	15-00221	8	Flat Washer 5/16" SAE	-
19	15-00708	4	Stud Washer 8.4mm ID x 21mm OD x 4mm	-
20	R128442	1	Fan Spacer 4 Bolt 49mm	-
21	AT24834	1	Fan 23" (Blower)	-
22	12-80049	4	Capscrew, Hex Head Flanged Socket, 10x1.5 x 80mm GR	-
24	RE57059	1	Fan Guard	-
25	15-70004	4	Snubbing Washer S/S 0.25" ID x 0.84	-
26	19-00032	1	Hose Clamp #32	-
27	R128480	1	Hose, Radiator Outlet	-
28	19-00036	1	Hose Clamp #36	-
29	19-00028	1	Hose Clamp #28	-
30	R128455	1	Hose, Radiator Inlet	-
31	21-10002	1	Drain Cock, Brass 1/4 NPT	-
32	41-01013	1	Hose, Polyvinyl 5/16" ID x 7/16" OD	-
33	RE64092	1	Cap, Coolant Fill 10 PSI	-
34	00-70082	1	Label, "Northern Lights" 2' x 22"	-

Fuel Injection System

L1064D, L1064T1, M1064D, M40C2, NL1064D, M1064T1, M55C2, & NL1064T1
with Mechanical Injection Pump

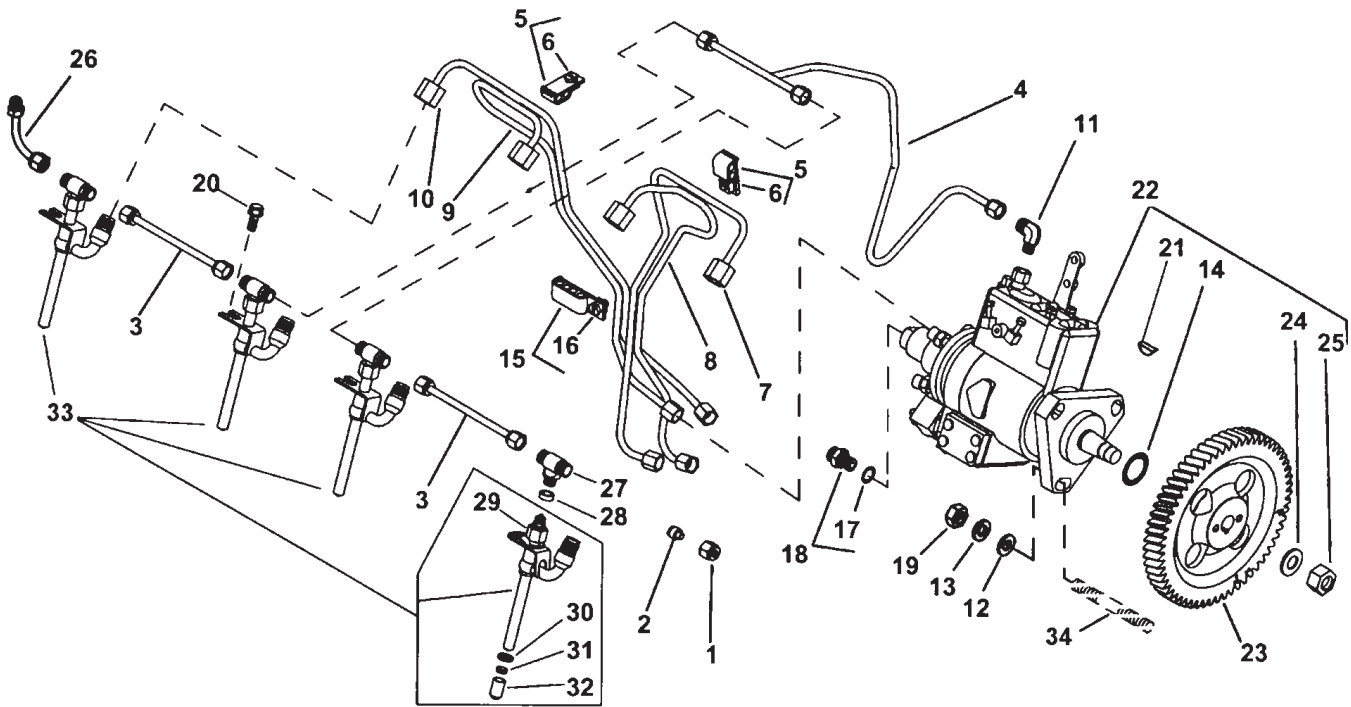

Fuel Injection System

L1064D, L1064T1, M1064D, M40C2, NL1064D, M1064T1, M55C2, & NL1064T1
with Mechanical Injection Pump

KEY	PART NUMBER	QTY	DESCRIPTION	SERIAL NUMBER
1	R123593	**	Nut	-
2	AR85519	2	Plug	-
3	RE68748	2	Tube Assembly (includes keys 1 & 26)	-
4	RE70848	1	Tube Assembly (includes keys 1 & 26)	-
5	RE19797	2	Clamp	-
6	19M7923	2	Capscrew, M6 x 12	-
7	RE59447	1	Fuel Line, No. 1	-
8	RE59448	1	Fuel Line, No. 2	-
9	RE59449	1	Fuel Line, No. 3	-
10	RE59450	1	Fuel Line, No. 4	-
11	R67364	1	Elbow Fitting	-
12	12M7065	3	Lock Washer	-
13	T27860	3	Washer	-
14	R502076	1	Back-up Ring	-
15	RE19799	1	Clamp	-
16	19M7923	1	Capscrew, M6 x 12	-
17	51M7040	1	O-ring	-
18	RE60029	1	Fitting M12 x 1.5 x 5/16" Tube Comp	-
19	14M7273	3	Nut, M8	-
20	R116366	4	Capscrew	-
21		**	Shaft Key*	-
22		1	Fuel Injection Pump - See Application Chart	-
23	R132267	1	Gear	-
24	R132874	1	Washer	-
25	R91360	1	Nut, M14	-
26	R51936	**	Tube Seal	-
27	R71963	4	Tee Fitting	-
28	R79605	4	Washer	-
29	R79604	1	Tube Nut	-
30	R92352	1	Packing	-
31	R500390	1	Washer	-
32	T24472	1	Plug	-
33	RE519569	4	Injection Nozzle L, M, NL1064D	-
	RE48786	4	Injection Nozzle L1064T1, M1064T1, NL1064T1	-
34	R116386	3	Stud	-

*See pump repair shop for part numbers not listed.
**As required

Double Wall Fuel Lines

M1064D- T1 & M40C2, M55C2

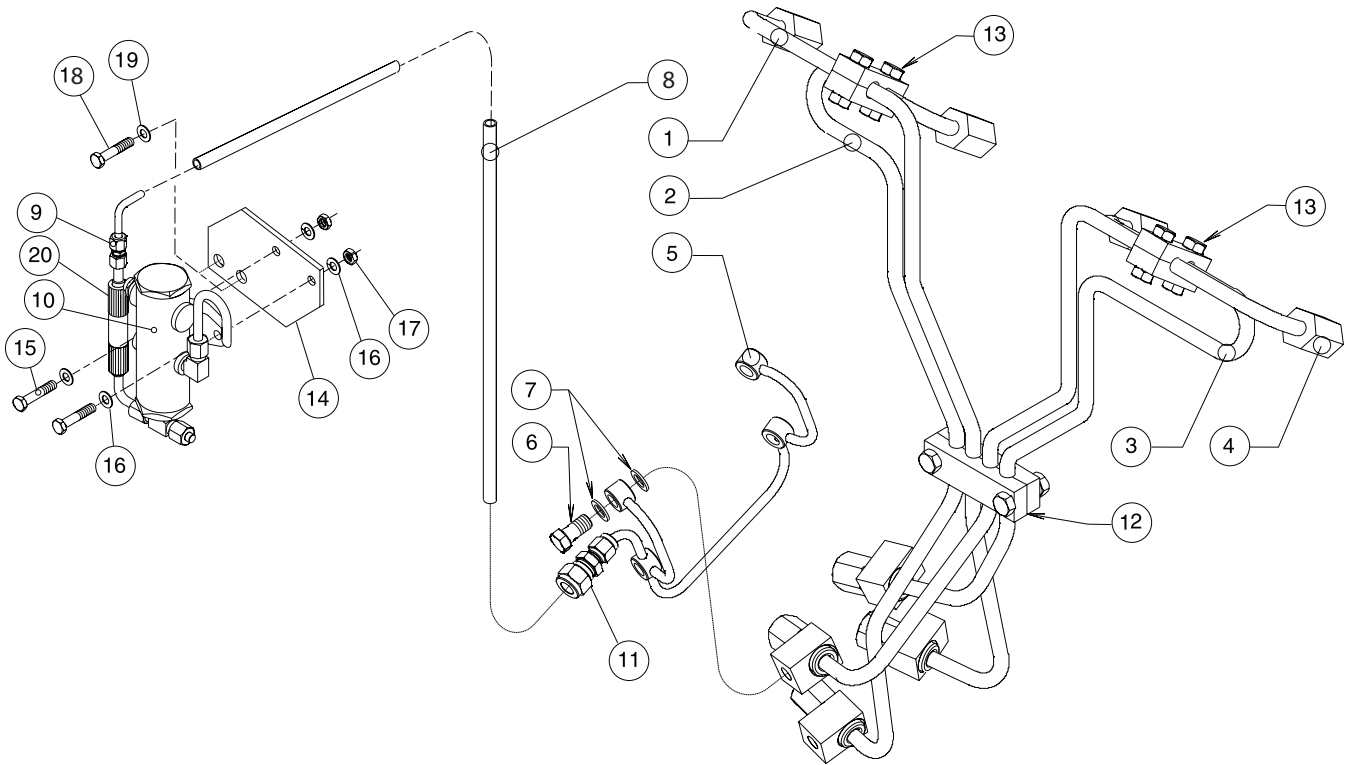

A-9202/ ST13097-1, ST14555-2

Double Wall Fuel Lines

M1064D- T1 & M40C2, M55C2

KEY	PART NUMBER	QTY	DESCRIPTION	SERIAL NUMBER
1	27-59401	1	Injection Line #1 Double Wall	-
2	27-59402	1	Injection Line #2 Double Wall	-
3	27-59403	1	Injection Line #3 Double Wall	-
4	27-59404	1	Injection Line #4 Double Wall	-
5	10-59401	1	Drain Manifold	-
6	21-59504	4	Banjo Bolt M8 x .75 x 16 mm	-
7	15-59501	8	Sealing Washer, Copper M8	-
8	43-00008	1	Tubing 8 mm OD	-
9	21-55703	1	Union, Steel 8 mm	-
10	10-50002	1	Alarm Tank Assembly	-
11	21-50041	1	Reducing Union Brass 3/16 x 5/16	-
12	19-50014	1	Clamp Assembly, 4 Lines	-
13	19-50012	2	Clamp Assembly, 2 Lines	-
14	23-59601	1	Bracket, Alarm Tank Mtg.	-
15	12-00753	2	Capscrew, Hex Head M8 x 1.25 x 30 mm	-
16	15-00701	4	Flat Washer M8	-
17	14-04802	2	Hex Nut, Nylock M8 x 1.25	-
18	12-00911	2	Capscrew, Hex Head M12 x 1.75 x 20 mm	-
19	15-00912	2	Lock Washer, Helical M12	-

Fuel Injection System

M1064T2, M65C2, NL1064T2, L1064A, M1064A, & NL1064H1
DE10 Electronic Pump

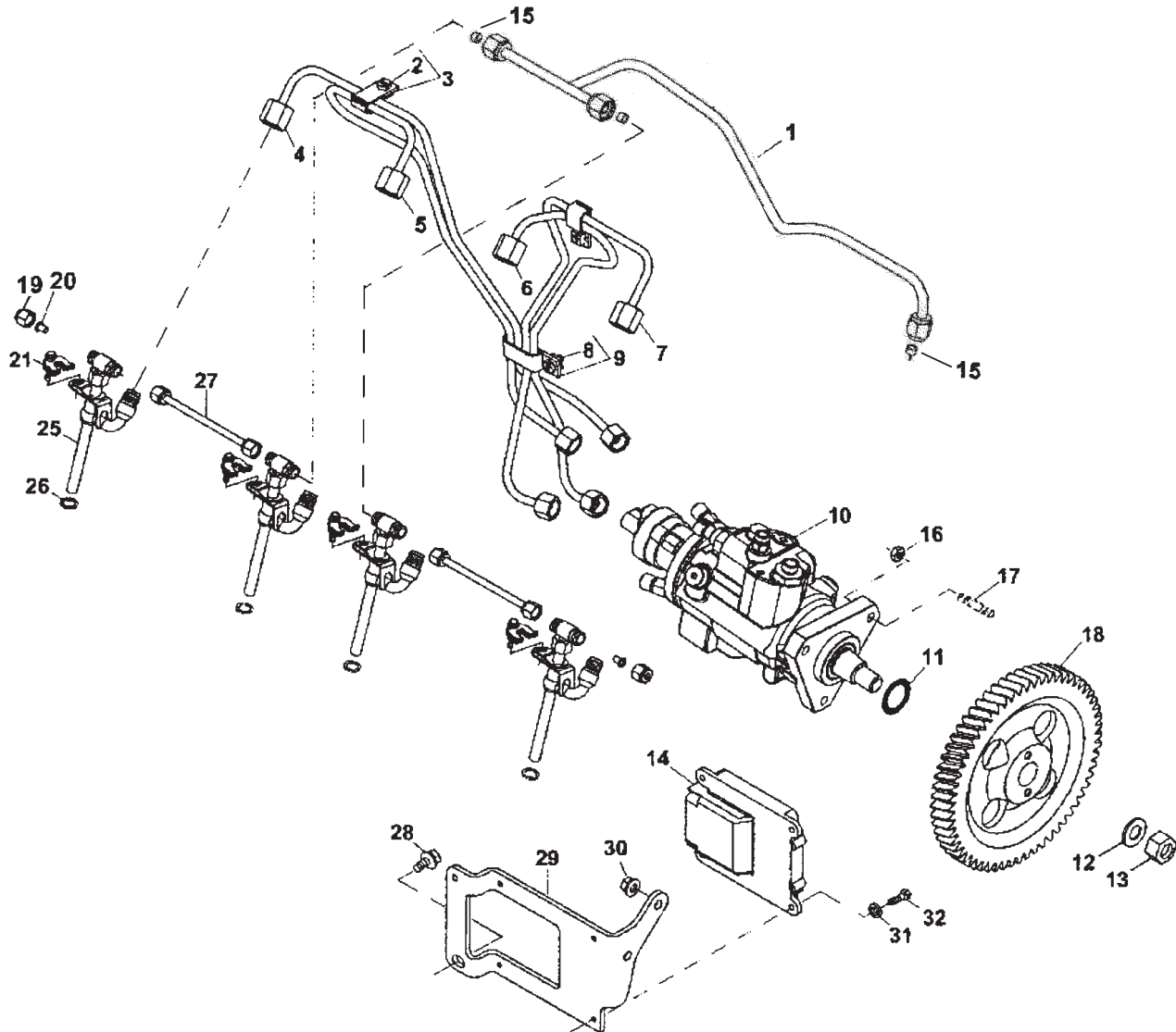

Fuel Injection System

M1064T2, M65C2, NL1064T2, L1064A, M1064A, & NL1064H1
DE10 Electronic Pump

KEY	PART NUMBER	QTY	DESCRIPTION	SERIAL NUMBER
1	RE507815	1	Fuel Line	-
2	19M7923	2	Capscrew	-
3	RE19797	2	Clamp	-
4	RE507649	1	Fuel Line, No. 4	-
5	RE507648	1	Fuel Line, No. 3	-
6	RE507647	1	Fuel Line, No. 2	-
7	RE507646	1	Fuel Line, No. 1	-
8	19M7923	1	Capscrew	-
9	RE19799	1	Clamp	-
10		1	Fuel Injection Pump - See Application Chart	-
11	R502076	1	Back-up Ring	-
12	R132874	1	Washer	-
13	R91360	1	Nut	-
14		1	Engine Controller 12V or 24V - See Application Chart	-
15	R51936	**	Sealing Washer	-
16	14M7298	1	Flange Nut	-
17	R116386	1	Stud	-
18	R505472	1	Gear	-
19	R123593	2	Tube Nut	-
20	AR85519	2	Plug	-
21	RE508716	4	Clamp	-
25	RE531436	4	Fuel Injector M1064T2 @ 1800 RPM, NL1064T2, L1064A, & NL1064H1 (includes key 26, formerly #RE507766)	-
	RE531436	4	Fuel Injector M1064T2 @ 1500 RPM (formerly #RE507766)	up to S/N xxxx-36553
	RE48786	4	Fuel Injector M1064A	-
26	R92352	4	Packing	-
27	RE68748	2	Tube	-
28	19M7784	1	Screw, M10 x 20	-
29	R503520	1	Bracket	-
30	14M7298	2	Flange Nut	-
31	24M7027	4	Washer	-
32	19M7640	4	Capscrew	-
	16-59502	**	O-ring, Return Tee (2 ea. per injector - not shown)	-
	26-59502	**	Tee, Fuel Injector Return (leaper injector - not shown)	-
	RE531438	**	Kit, Fuel Injector Return (includes return tee 26-59502 & O-Ring 16-59502)	-
			**As required	

Fuel Injection System

M1064T2 @1500 RPM
DE10 Electronic Pump

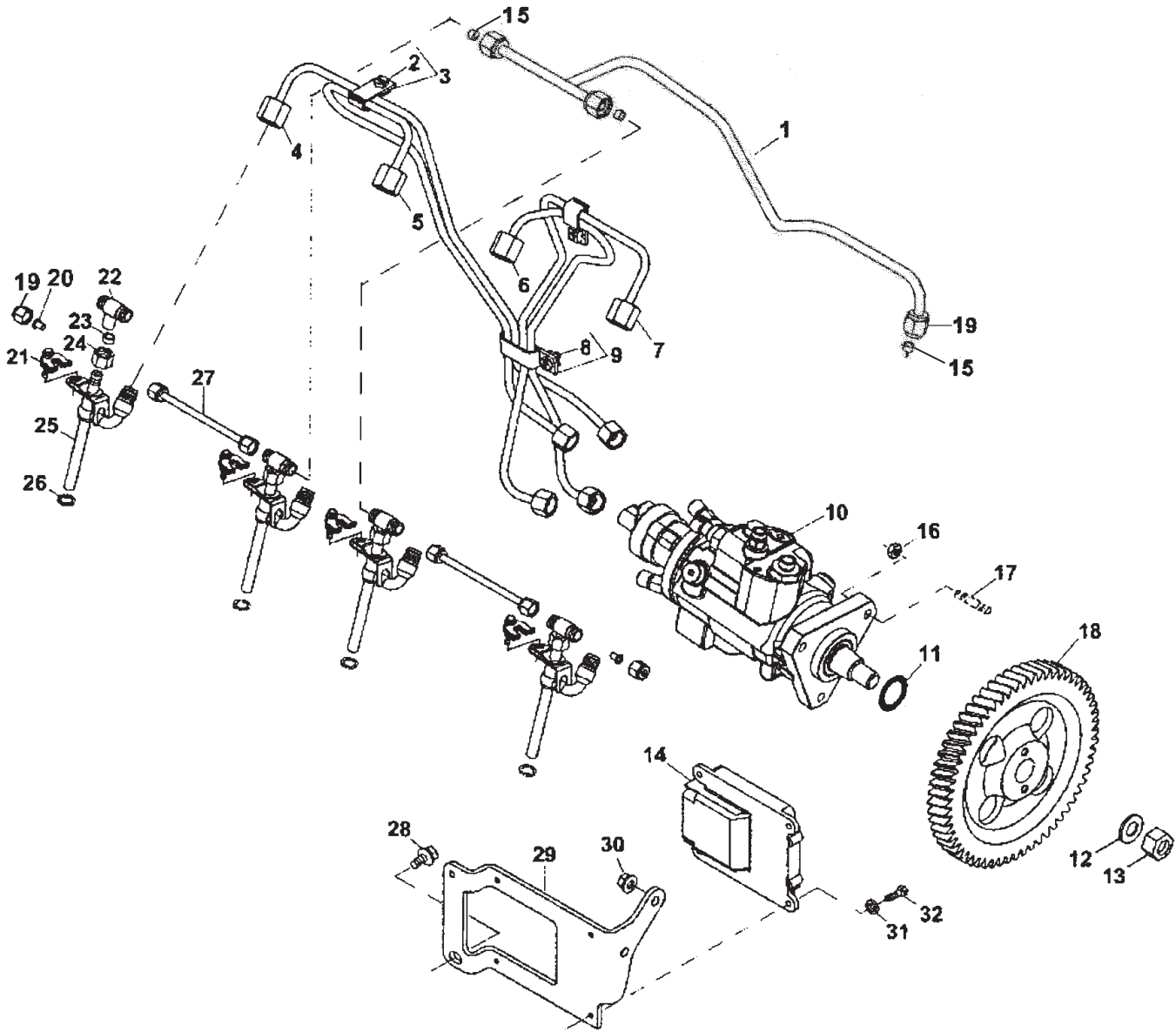

Fuel Injection System

M1064T2 @ 1500 RPM
DE10 Electronic Pump

KEY	PART NUMBER	QTY	DESCRIPTION	SERIAL NUMBER
1	RE507598	1	Fuel Return Line	from xxxx-36554
2	19M7923	2	Capscrew	
3	RE19797	2	Clamp	
4	RE507649	1	Fuel Line, No. 4	
5	RE507648	1	Fuel Line, No. 3	
6	RE507647	1	Fuel Line, No. 2	
7	RE507646	1	Fuel Line, No. 1	
8	19M7923	1	Capscrew	
9	RE19799	1	Clamp	
10		1	Fuel Injection Pump - See Application Chart	
11	R502076	1	Back-up Ring	
12	R132874	1	Washer	
13	R91360	1	Nut	
14		1	Engine Controller 12V or 24V - See Application Chart	
15	R51936	**	Sealing Washer	
16	14M7298	1	Flange Nut	
17	R116386	1	Stud	
18	R505472	1	Gear	
19	R123593	2	Tube Nut	
20	AR85519	2	Plug	
21	19M7866	4	Capscrew, Hex Head Flanged M8 x 1.25 x 20 mm	
22	R79606	4	Tee Fitting	
23	R79605	4	Washer	
24	R79604	4	Tube Nut	
25	RE522542	4	Fuel Injector	
26	R92352	4	Packing	
27	RE68748	2	Tube Assembly, Fuel Return	
28	19M7784	1	Screw, M10 x 20	
29	R503520	1	Bracket	
30	14M7298	2	Flange Nut	
31	24M7027	4	Washer	
32	19M7640	4	Capscrew	
			**As required	

GROUP 4 - FUEL SYSTEM

Double Wall Fuel Lines

L1064A, M1064T2- A, & M65C2

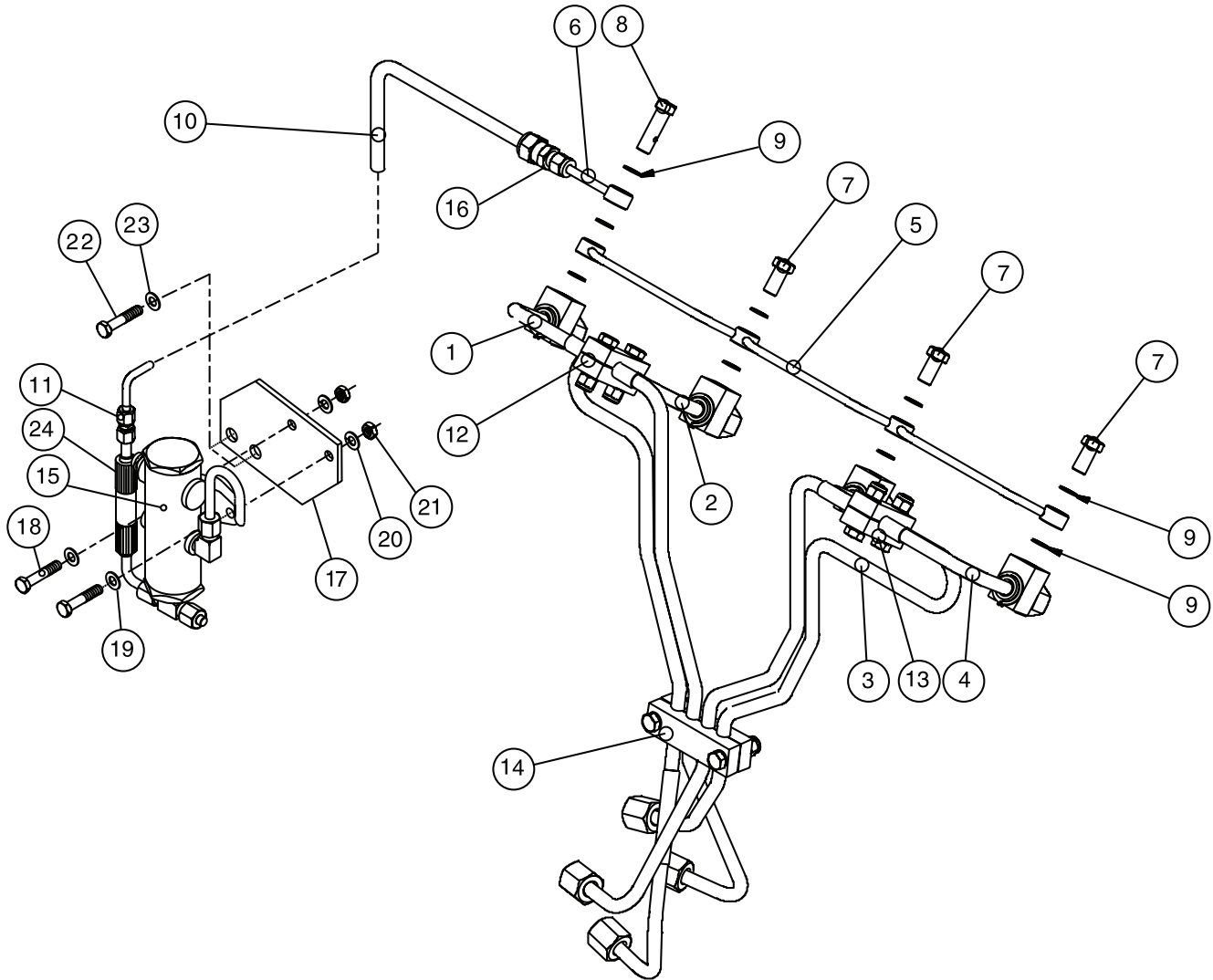

A-10632/ ST14475-2

Double Wall Fuel Lines

L1064A, M1064T2- A, & M65C2

KEY	PART NUMBER	QTY	DESCRIPTION	SERIAL NUMBER
1	27-59421	1	Injection Line #1 Double Wall	up to S/N xxxx-50473
2	27-59422	1	Injection Line #2 Double Wall	up to S/N xxxx-50473
3	27-59423	1	Injection Line #3 Double Wall	up to S/N xxxx-50473
4	27-59424	1	Injection Line #4 Double Wall	up to S/N xxxx-50473
5	27-59413	1	Tube, Fuel Return to Alarm Tank	up to S/N xxxx-50473
6	27-59506	1	Tube, Fuel Return to Alarm Tank *	up to S/N xxxx-50473
7	21-59504	3	Banjo Bolt M8 x 0.75 x 16 mm	up to S/N xxxx-50473
8	21-59516	1	Banjo Bolt	up to S/N xxxx-50473
9	15-59501	9	Sealing Washer, Copper M8	up to S/N xxxx-50473
10	18-59508	1	Hose Assembly 1/4" I.D. x 31" S/S	up to S/N xxxx-50473
12	19-50012	1	Clamp Assembly, 2 Lines *	up to S/N xxxx-50473
13	19-59401	1	Clamp Assembly, 2 Lines *	up to S/N xxxx-50473
14	19-50014	1	Clamp Assembly, 4 Lines	up to S/N xxxx-50473
15	10-50002	1	Alarm Tank Assembly	up to S/N xxxx-50473
16	21-59541	1	Reducing Union, Brass 3/16 x 5/16 x 5/16 *	up to S/N xxxx-50473
17	23-59601	1	Bracket, Alarm Tank Mounting	up to S/N xxxx-50473
18	12-00711	2	Capscrew, Hex Head M8 x 1.25 x 20 mm	up to S/N xxxx-50473
19	15-00701	2	Flat Washer, M8	up to S/N xxxx-50473
20	15-00702	2	Lock Washer, Helical M8	up to S/N xxxx-50473
21	14-00711	2	Hex Nut, M8 x 1.25	up to S/N xxxx-50473
22	12-00911	2	Capscrew, Hex Head M12 x 1.75 x 20 mm	up to S/N xxxx-50473
23	15-00912	2	Lock Washer, Helical M12	up to S/N xxxx-50473
24	18-59509	1	Hose Assembly 1/4" I.D. x 6" S/S - TFE *	up to S/N xxxx-50473
<p>* Items marked can be replaced with #6 Fuel Return Tube 27-59516 #7 Fuel Return Hose 18-59524 #16 Swivel 90° Adaptor Fitting 21-59536 Adaptor on units Frome serial # xxxx-50474</p>				

GROUP 4 - FUEL SYSTEM

Double Wall Fuel Lines

L1064A, M1064T2- A, & M65C2

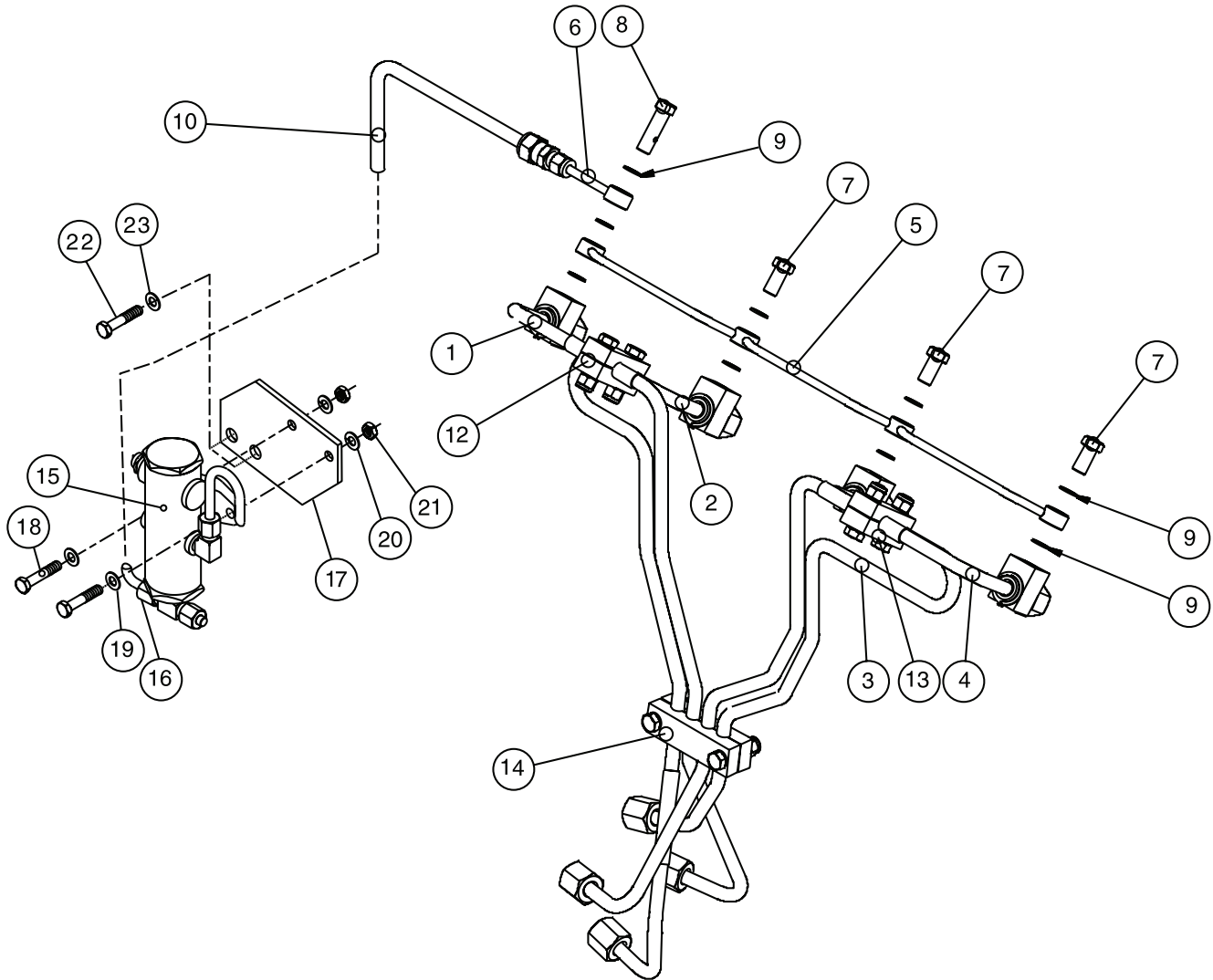

A-10632/ ST14475-2

Double Wall Fuel Lines

L1064A, M1064T2- A, & M65C2

KEY	PART NUMBER	QTY	DESCRIPTION	SERIAL NUMBER
1	27-59421	1	Injection Line #1 Double Wall	from S/N xxxx-50474
2	27-59422	1	Injection Line #2 Double Wall	from S/N xxxx-50474
3	27-59423	1	Injection Line #3 Double Wall	from S/N xxxx-50474
4	27-59424	1	Injection Line #4 Double Wall	from S/N xxxx-50474
5	27-59413	1	Tube, Fuel Return to Alarm Tank	from S/N xxxx-50474
6	27-59516	1	Tube, Fuel Return to Alarm Tank M8 Banjo x 6L Flareless	from S/N xxxx-50474
7	21-59504	3	Banjo Bolt M8 x 0.75 x 16 mm	from S/N xxxx-50474
8	21-59516	1	Banjo Bolt	from S/N xxxx-50474
9	15-59501	9	Sealing Washer, Copper M8	from S/N xxxx-50474
10	18-59524	1	Hose Assembly 1/4" I.D. x 31" S/S	from S/N xxxx-50474
12	19-50012	1	Clamp Assembly, 2 Lines	from S/N xxxx-50474
13	19-59401	1	Clamp Assembly, 2 Lines	from S/N xxxx-50474
14	19-50014	1	Clamp Assembly, 4 Lines	from S/N xxxx-50474
15	10-50003	1	Alarm Tank Assembly	from S/N xxxx-50474
16	21-59536	1	Female 90° Swivel Adapter M14 x 1.5 x M8 compression	from S/N xxxx-50474
17	23-59601	1	Bracket, Alarm Tank Mounting	from S/N xxxx-50474
18	12-00711	2	Capscrew, Hex Head M8 x 1.25 x 20 mm	from S/N xxxx-50474
19	15-00701	2	Flat Washer, M8	from S/N xxxx-50474
20	15-00702	2	Lock Washer, Helical M8	from S/N xxxx-50474
21	14-00711	2	Hex Nut, M8 x 1.25	from S/N xxxx-50474
22	12-00911	2	Capscrew, Hex Head M12 x 1.75 x 20 mm	from S/N xxxx-50474
23	15-00912	2	Lock Washer, Helical M12 *	from S/N xxxx-50474

GROUP 4 - FUEL SYSTEM

Double Wall Fuel Lines

M1064H High Pressure Common Rail

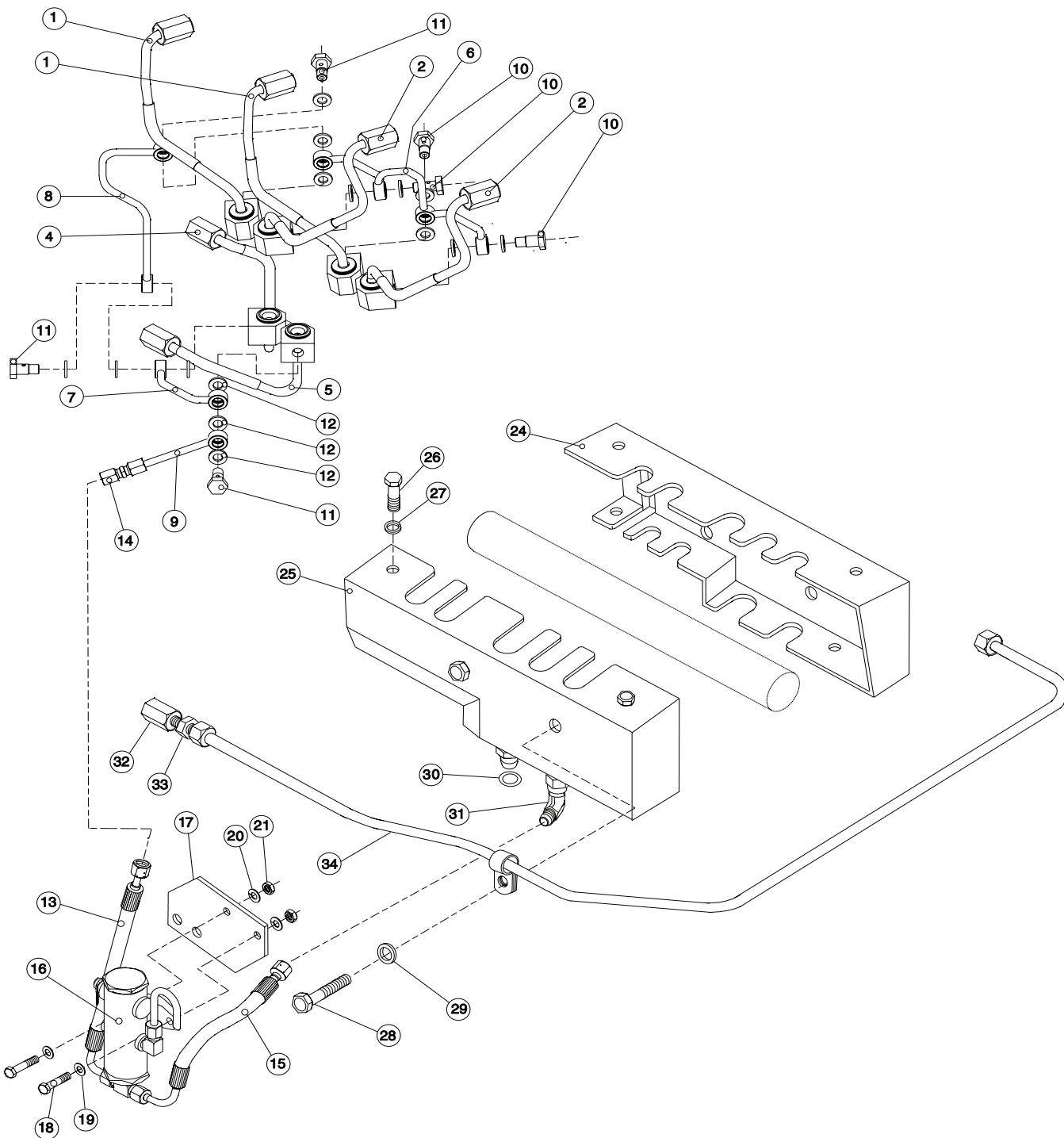

A-10633/ ST14488-1

Double Wall Fuel Lines

M1064H High Pressure Common Rail

KEY	PART NUMBER	QTY	DESCRIPTION	SERIAL NUMBER
1	27-59512	1	Injection Line #1 & #2 Double Wall	-
2	27-59534	1	Injection Line #3 & #4 Double Wall	-
4	27-59504	1	Tube Assembly, HPCR Manifold Inlet	-
5	27-59505	1	Tube Assembly, HPCR Manifold Supply #2	-
6	27-59414	1	Tube, Fuel Return to Alarm Tank, Upper	-
7	27-59507	1	Tube, Fuel Return to Alarm Tank, Lower	-
8	27-59508	1	Tube, Fuel Return to Alarm Tank	-
9	27-59509	1	Tube, Fuel Return to Alarm Tank	-
10	21-59517	3	Banjo Bolt	-
11	21-59518	3	Banjo Bolt, Double Length	-
12	15-55701	15	Banjo Washer	-
13	18-59512	1	Hose Assembly 1/4" I.D. x 12" S/S- TFE	-
14	21-59514	1	Reducing Union, Steel 8 mm x 6 mm	-
15	18-59513	1	Hose Assembly, 1/4" I.D. 13" S/S- TFE	-
16	10-50002	1	Alarm Tank Assembly	-
17	23-59601	1	Bracket, Alarm Tank Mtg.	-
18	12-00711	2	Capscrew, Hex Head M8 x 1.25 x 20 mm	-
19	15-00701	2	Flat Washer M8	-
20	15-00702	2	Lock Washer, Helical M8	-
21	14-00711	2	Hex Nut M8 x 1.25	-
22	12-00911	2	Capscrew, Hex Head M12 x 1.75 x 20 mm	-
23	15-00912	2	Lock Washer, Helical M12	-
24	10-59411	1	Rear Cover, HPCR Manifold	-
25	10-59412	1	Front Cover, HPCR Manifold	-
26	12-00029	4	Capscrew, Hex Head M6 x 1.0 x 10 mm S/S	-
27	15-00610	4	Lock Washer, Helical M6 S/S	-
28	12-09048	2	Capscrew, Hex Head M10 x 1.5 x 60 mm S/S	-
29	15-09805	2	Flat Washer M10 S/S	-
30	16-15006	1	O-ring	-
31	21-59519	1	Elbow, 45° Swivel Steel 3/8- 37T	-
32	21-00056	1	Female Adapter, Steel 1/4 NPT x M14 x 1.5	-
33	21-09702	1	Male Connector, Brass 1/4 NPT x 3/8" Tube	-
34	27-59412	1	Tube Assembly, Final Fuel Filter Outlet	-

GROUP 4 - FUEL SYSTEM

Double Wall Fuel Lines

M1064H High Pressure Common Rail

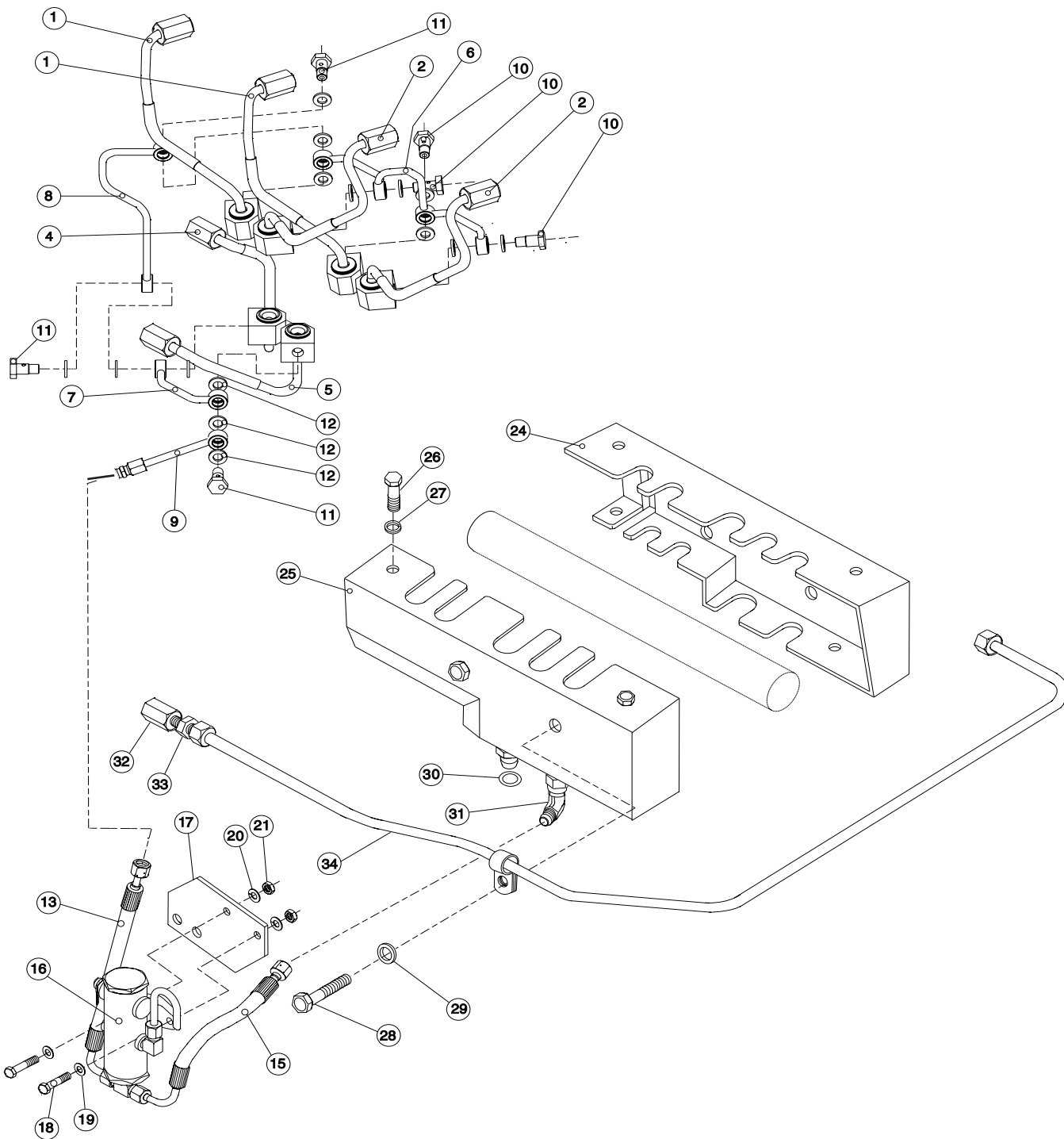

A-10633/ ST14488-1

Double Wall Fuel Lines

M1064H High Pressure Common Rail

KEY	PART NUMBER	QTY	DESCRIPTION	SERIAL NUMBER
1	27-59512	1	Injection Line #1 & #2 Double Wall	-
2	27-59534	1	Injection Line #3 & #4 Double Wall	-
4	27-59504	1	Tube Assembly, HPCR Manifold Inlet	-
5	27-59505	1	Tube Assembly, HPCR Manifold Supply #2	-
6	27-59414	1	Tube, Fuel Return to Alarm Tank, Upper	-
7	27-59507	1	Tube, Fuel Return to Alarm Tank, Lower	-
8	27-59508	1	Tube, Fuel Return to Alarm Tank	-
9	27-59517	1	Tube, Fuel Return to Alarm Tank	-
10	21-59517	3	Banjo Bolt	-
11	21-59518	3	Banjo Bolt, Double Length	-
12	15-55701	15	Banjo Washer	-
13	18-59523	1	Hose Assembly 1/4" I.D. x 13" S/S- TFE	-
15	18-59513	1	Hose Assembly, 1/4" I.D. 13" S/S- TFE	-
16	10-50003	1	Alarm Tank Assembly	-
17	23-59601	1	Bracket, Alarm Tank Mtg.	-
18	12-00711	2	Capscrew, Hex Head M8 x 1.25 x 20 mm	-
19	15-00701	2	Flat Washer M8	-
20	15-00702	2	Lock Washer, Helical M8	-
21	14-00711	2	Hex Nut M8 x 1.25	-
22	12-00911	2	Capscrew, Hex Head M12 x 1.75 x 20 mm	-
23	15-00912	2	Lock Washer, Helical M12	-
24	10-59411	1	Rear Cover, HPCR Manifold	-
25	10-59412	1	Front Cover, HPCR Manifold	-
26	12-00029	4	Capscrew, Hex Head M6 x 1.0 x 10 mm S/S	-
27	15-00610	4	Lock Washer, Helical M6 S/S	-
28	12-09048	2	Capscrew, Hex Head M10 x 1.5 x 60 mm S/S	-
29	15-09805	2	Flat Washer M10 S/S	-
30	16-15006	1	O-ring	-
31	21-59519	1	Elbow, 45° Swivel Steel 3/8- 37T	-
32	21-00056	1	Female Adapter, Steel 1/4 NPT x M14 x 1.5	-
33	21-09702	1	Male Connector, Brass 1/4 NPT x 3/8" Tube	-
34	27-59412	1	Tube Assembly, Final Fuel Filter Outlet	-

GROUP 4 - FUEL SYSTEM

Fuel Injection System

M1064H & NL1064H2

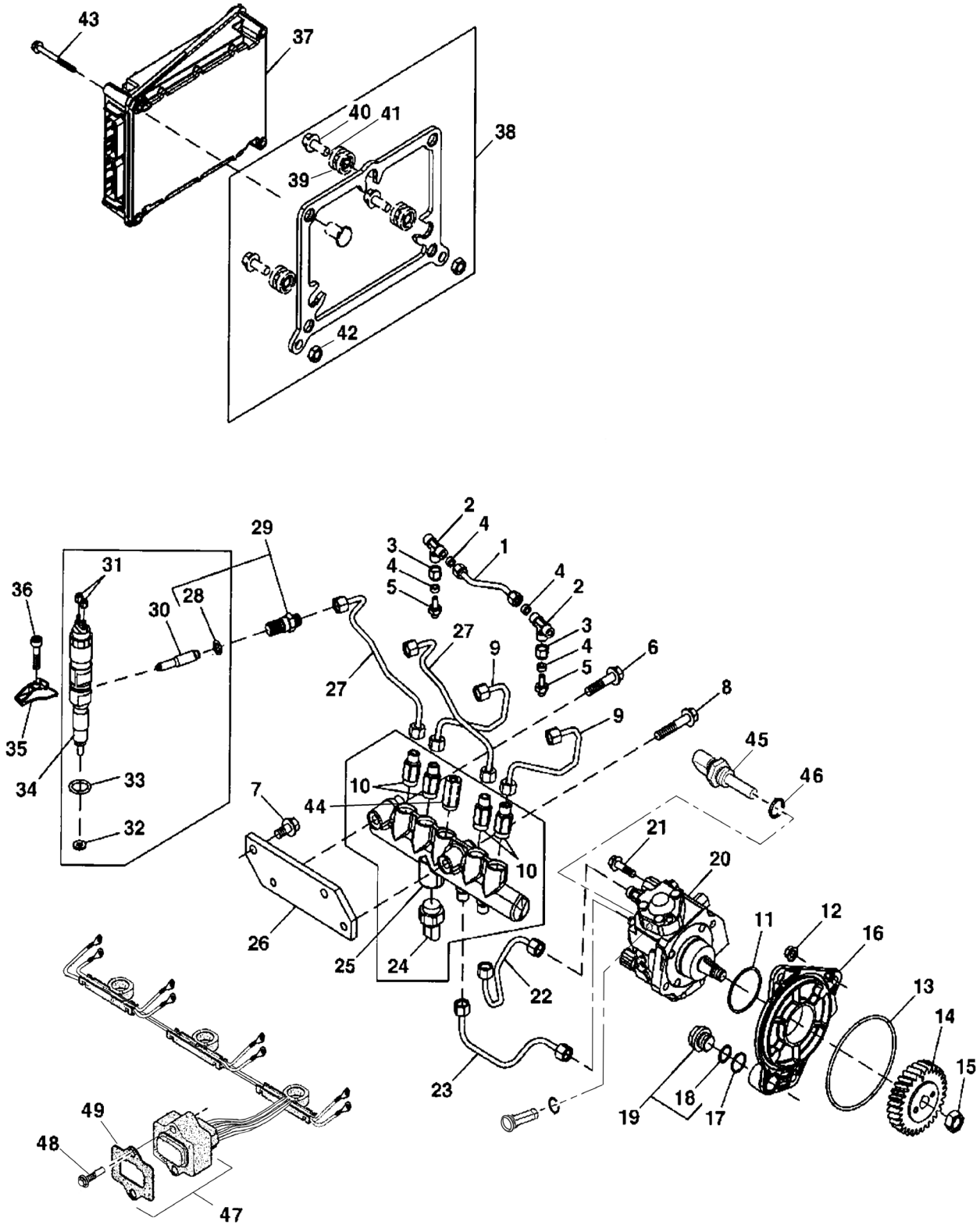

Reproduced by permission of Deere & Co., c2005. Deere & Company. All rights reserved.

RE517142SPA

Fuel Injection System

M1064H & NL1064H2

KEY	PART NUMBER	QTY	DESCRIPTION	SERIAL NUMBER
1	R503307	2	Tube	-
2	R97061	4	Tee Fitting	-
3	R123593	8	Tube Nut	-
4	R51936	8	Sealing Washer	-
5	R503308	4	Fitting	-
6	19M8320	1	Capscrew, M10 x 45	-
7	19M7784	2	Capscrew, M10 x 20	-
8	19M8528	1	Capscrew, M10 x 55	-
9	RE507539	2	Injection Line #1 and #2	-
10	RE515636	4	Restrictor	-
11	R516125	1	O-ring	-
12	14M7298	3	Flange Nut, M8	-
13	R55453	1	O-ring	-
14	R502541	1	Gear	-
15	R91360	1	Nut	-
16	R504577	1	Adapter	-
17	R116031	1	O-ring	-
18	51M7044	1	O-ring	-
19	RE501938	1	Plug	-
20	RE507959	1	Pump	-
21	19M7868	2	Capscrew, M8 x 30	-
22	RE507537	1	Fuel Line	-
23	RE507538	1	Fuel Line	-
24	RE520930	1	Sensor, Fuel Manifold Pressure (former # RE515635)	-
25	RE507972	1	Rail	-
26	R504578	1	Bracket	-
27	RE507540	2	Injection Line #3 and #4	-
28	R65397	4	O-ring	-
29	R515044	4	Nut	-
30	RE515986	4	Tube	-
31	R134920	8	Nut	-
32	R515535	4	Washer	-
33	R505452	4	O-ring	-
34	RE516540	4	Fuel Injector, Electronic Unit Type M1064H @ 1800 RPM & NL1064H2	-
	RE519730	4	Fuel Injector, Electronic Unit Type M1064H @ 1500 RPM	-
35	R504779	4	Clamp	-
36	R504781	4	Capscrew	-
37		1	Engine Controller - see Application Chart	-
38	RE500588	1	Bracket (includes keys 39, 40, 41, 42)	-
39	R500488	3	Isolator	-
40	12-00814	3	Capscrew, Hex Head M10 x 1.5 x 35 mm	-
41	15-70006	3	Flat Washer (Special)	-
42	14-00812	3	Hex Nut, Nylock M10 x 1.5	-
43	19M8804	4	Capscrew, M6 x 65	-
44	RE516335	1	Relief Valve	-
45	RE516336	1	Sensor, Fuel Temperature	-
46	R50919	1	O-ring	-
47	RE509112	1	Wiring Harness	-
48	19M7775	2	Capscrew, M6 x 16	-
49	R520740	1	Gasket	-

GROUP 4 - FUEL SYSTEM

Injection Pump Applications

PART NUMBER	DESCRIPTION
	Marine & Industrial Generator Units, Mechanical Pumps
	M1064D, M40C2, & NL1064D
RE519023	1800 RPM 12 Volt
26-59408	1800 RPM 24 Volt
26-59409	1500 RPM 12 Volt
26-59411	1500 RPM 24 Volt
	M1064T1, M55C2, & NL1064T1
RE519069	1800 RPM 12 Volt
RE519070	1800 RPM 24 Volt
26-59412	1500 RPM 12 Volt
26-59413	1500 RPM 24 Volt
	Propulsion Units - Energize-to-stop Mechanical Pumps
	L1064D
RE519021XD	6 Volt Standard Ground (used on 12 volt systems)
RE519022XD	12 Volt Standard Ground (used on 24 volt systems)
	Propulsion Units - Energize-to-stop Mechanical Pumps
	L1064T1
RE519029XD	6 Volt Standard Ground (used on 12 volt systems)
RE519030XD	12 Volt Standard Ground (used on 24 volt systems)
	Note for Mechanical Pumps: Basic injection pump part numbers are listed above. Alaska Diesel Electric also provides special accessories. Injection pump part numbers may show suffix letters indicating an optional configuration. Please order replacement pumps using complete part number on data plate.
	Example: RE519023XB - Pump has been configured to isolated ground solenoid and includes lever for use with governor actuator.
	Propulsion Units, Marine and Industrial Generator Units - Electronic Pumps
	M1064T2 - NL1064T2 - M65C2
RE568070	1800 RPM 12/24 Volt (and 1500 RPM Marine up to ADE S/N xxxx-36553)(former # RE518087 & RE518166)
RE568071	1500 RPM 12/24 Volt (from ADE S/N xxxx-36554)(former # RE518086 & RE51867)
	L1064A, M1064A, and NL1064H1
RE568071	All RPM 12/24 Volt (former # RE518086 & RE518167)
RE507959	M1064H & NL1064H2

Engine Control Unit Applications

Propulsion Engines (Serial number must be provided when ordering)

L1064A DE10 System

26-9940112C115 115 Hp @ 2000 RPM 12 Volt
 26-9940124C115 115 Hp @ 2000 RPM 24 Volt
 26-9940112M125 125 Hp @ 2200 RPM 12 Volt
 26-9940124M125 125 Hp @ 2200 RPM 24 Volt
 26-9940112H140 140 Hp @ 2400 RPM 12 Volt
 26-9940124H140 140 Hp @ 2400 RPM 24 Volt

Generator Units (Serial number must be provided when ordering)

M1064T2 & M65C2 DE10 System

26-9940112665 65 kW @ 1800 RPM 12 Volt
 26-9940124665 65 kW @ 1800 RPM 24 Volt
 26-9940112555 55 kW @ 1500 RPM 12 Volt
 26-9940124555 55 kW @ 1500 RPM 24 Volt

NL1064T2 DE10 System

26-9940112670 70 kW @ 1800 RPM 12 Volt
 26-9940124670 70 kW @ 1800 RPM 24 Volt

M1064A DE10 System

26-9940112692 92 kW @ 1800 RPM 12 Volt
 26-9940124692 92 kW @ 1800 RPM 24 Volt
 26-9940112567 67 kW @ 1500 RPM 12 Volt
 26-9940124567 67 kW @ 1500 RPM 24 Volt

NL1064H1 DE10 System

26-9940112694 94 kW @ 1800 RPM 12 Volt
 26-9940124694 94 kW @ 1800 RPM 24 Volt

M1064H High Pressure Common Rail

26-9940200699 99 kW @ 1800 RPM 12 or 24 Volt
 26-9940200590 90 kW @ 1500 RPM 12 or 24 Volt

NL1064H2 High Pressure Common Rail

26-99402006120 120 kW @ 1800 RPM 12 or 24 Volt

Fuel Injector

L1064D, M1064D, NL1064D, & M40C2

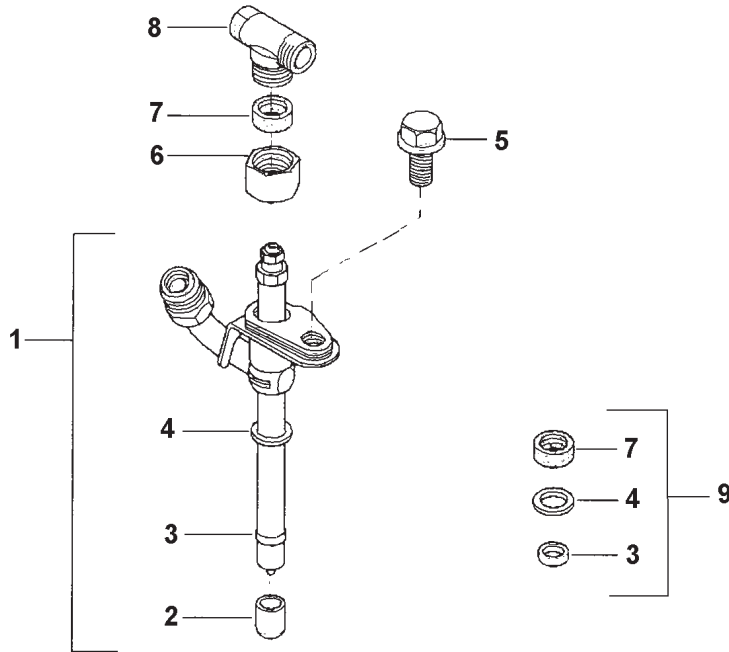

Reproduced by permission of Deere & Co., c2007. Deere & Company. All rights reserved.

CDP45007A

KEY	PART NUMBER	QTY	DESCRIPTION	SERIAL NUMBER
1	RE519569	1	Fuel Injector (includes keys 2-4)	-
	SE501180	1	Fuel Injector (remanufactured, pkg. 4)	-
	SE501179	1	Fuel Injector (remanufactured, pkg. 1)	-
2		1	Shipping Cap	-
3		1	Seal (not available separately)	-
4		1	Packing (not available separately)	-
5	R116366	4	Screw	-
6	R79604	1	Tube Nut	-
7	R79605	1	Packing	-
8	R71963	1	Tee Fitting	-
9	RE64292	**	Packing and Seal Kit (includes keys 3, 4, & 7)	-
			**As required	

Fuel Injector

L1064T1, M1064T1, M1064A, NL1064T1, & M55C2

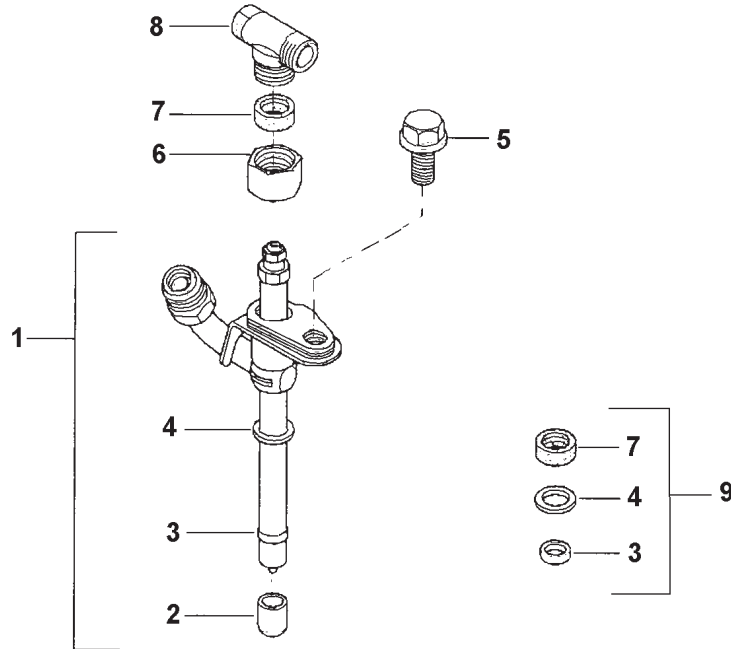

Reproduced by permission of Deere & Co., c2007. Deere & Company. All rights reserved.

CDP45007A

KEY	PART NUMBER	QTY	DESCRIPTION	SERIAL NUMBER
1	RE48786	1	Fuel Injector (includes keys 2-4)	-
	SE500826	1	Fuel Injector (remanufactured, pkg. 4)	-
	SE501101	1	Injection Nozzle (remanufactured, pkg. 1)	-
2		1	Shipping Cap	-
3		1	Seal (not available separately)	-
4		1	Packing (not available separately)	-
5	R116366	4	Screw	-
6	R79604	1	Tube Nut	-
7	R79605	1	Packing	-
8	R71963	1	Tee Fitting	-
9	RE64292	**	Packing and Seal Kit (includes keys 3, 4, & 7)	-
			**As required	

GROUP 4 - FUEL SYSTEM

Fuel Injector

L1064A, M1064T2, M65C2, NL1064T2, & NL1064H1

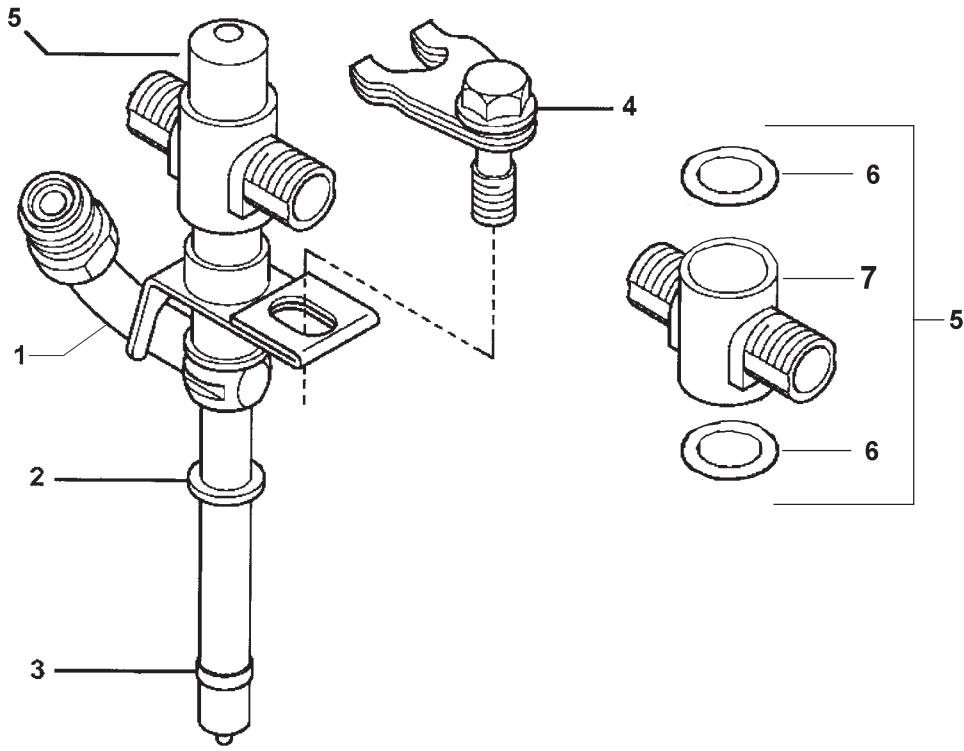

Reproduced by permission of Deere & Co., c2007. Deere & Company. All rights reserved.

CDP45118

KEY	PART NUMBER	QTY	DESCRIPTION	SERIAL NUMBER
1	RE531436	1	Fuel Injector (formerly RE507766, includes keys 1- 5)*	-
	SE501103	1	Fuel Injector (remanufactured)	-
2	R92352	1	Packing	-
3	R500390	1	Seal	-
4	RE508716	4	Clamp	-
5	RE531438	**	Return Tee Assembly (includes key 6)	-
6	16-59502	**	O-ring	-
7	26-59502	**	Tee, Fuel Injector Return	-
			*See M1064T2 fuel system for applicable serial numbers	
			**As required	

Fuel Injector

M1064T2 @ 1500 RPM

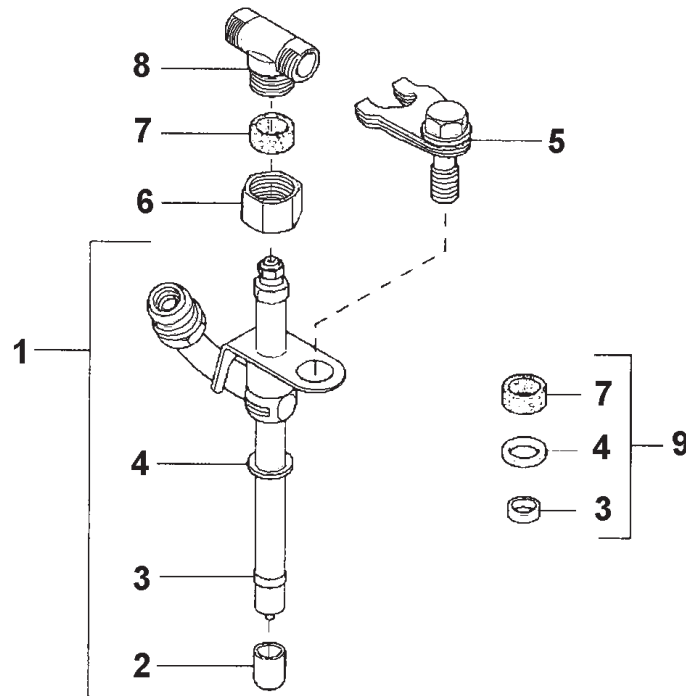

Reproduced by permission of Deere & Co., c2007. Deere & Company. All rights reserved.

CDP45970

KEY	PART NUMBER	QTY	DESCRIPTION	SERIAL NUMBER
1	RE522542	1	Fuel Injector (includes keys 2-4)	From s/n xxxx-36554
	SE501181	1	Fuel Injector (remanufactured)	-
2		1	Shipping Cap (not available separately)	-
3		1	Seal (not available separately)	-
4		1	Packing (not available separately)	-
5	RE508716	4	Clamp	-
6	R79604	1	Tube Nut	-
7	R79605	1	Packing	-
8	R71963	1	Tee Fitting	-
9	RE64292	**	Packing and Seal Kit (includes keys 3, 4, & 6)	-
			**As required	

Fuel Injector

M1064H @ 1800

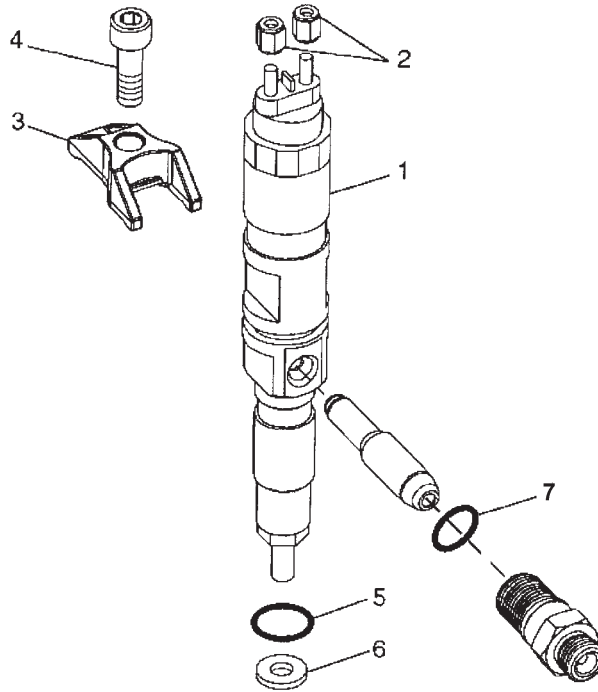

Reproduced by permission of Deere & Co., c2007. Deere & Company. All rights reserved.

RGP8843

KEY	PART NUMBER	QTY	DESCRIPTION	SERIAL NUMBER
1	RE516540	4	Injection Nozzle	-
2	R134920	8	Nut	-
3	R518345	4	Clamp	-
4	R504781	4	Capscrew, M8 x 35	-
5	R505452	4	O-ring	-
6	R515535	4	Washer	-
7	R65397	4	O-Ring	-
			**As required	

Fuel Injector

M1064H @ 1500

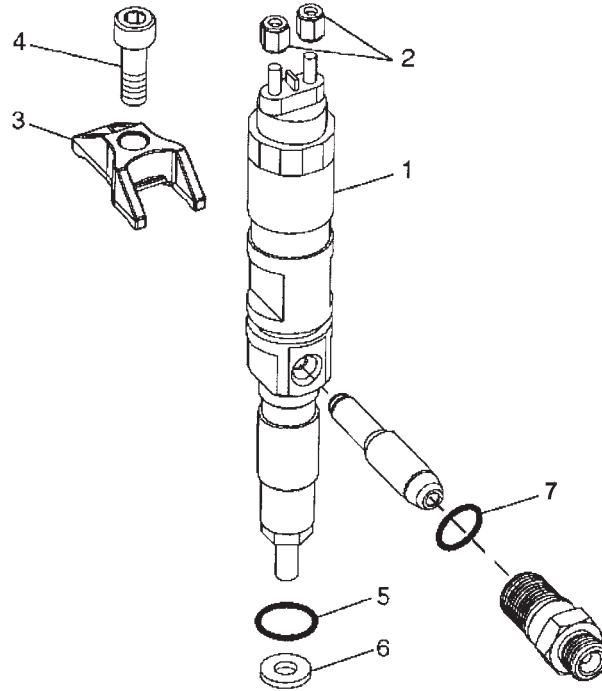

Reproduced by permission of Deere & Co., c2007. Deere & Company. All rights reserved.

RGP8843

KEY	PART NUMBER	QTY	DESCRIPTION	SERIAL NUMBER
1	RE519730	4	Fuel Injector (includes keys 2-6)	-
2	R134920	8	Nut	-
3	R518345	4	Clamp	-
4	R504781	4	Capscrew	-
5	R505452	4	O-ring	-
6	R515535	4	Washer	-
7	R65397	4	O-Ring	-

Fuel Filter and Fuel Lines

L1064D, M1064D, M40C2, NL1064D, M1064T1, M55C2, & NL1064T1

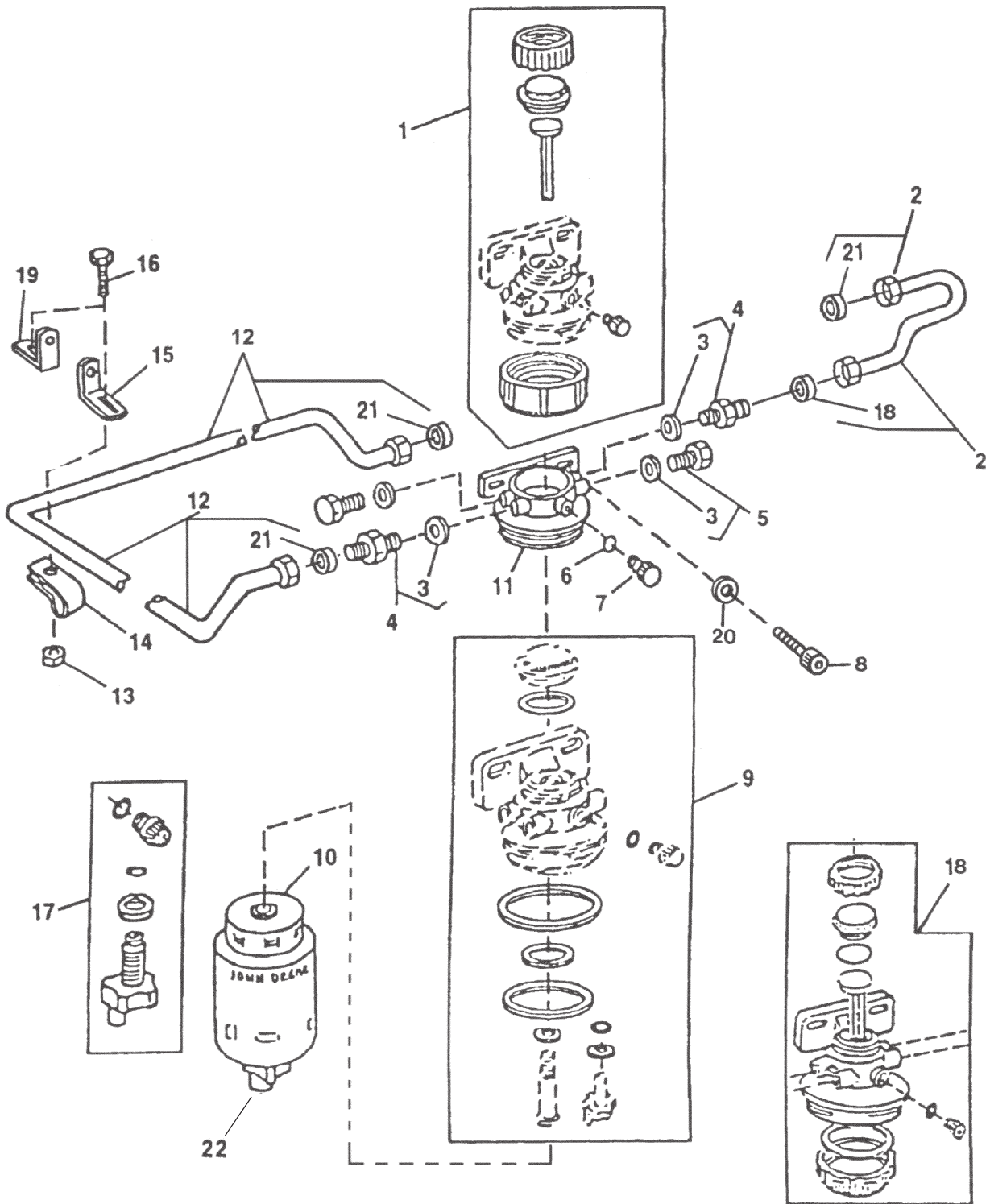

Fuel Filter and Fuel Lines

L1064D, M1064D, M40C2, NL1064D, M1064T1, M55C2, & NL1064T1

KEY	PART NUMBER	QTY	DESCRIPTION	SERIAL NUMBER
1	RE51649	1	Seal Kit	-
2	RE60037	1	Tube Assembly (includes key #21)	-
3	51M7040	1	O-ring	-
4	RE60029	2	Fitting (includes key #3)	-
5	RE46686	1	Plug (includes key #3)	-
6	16-59501	1	O-ring	-
7	21-59505	1	Vent Plug	-
8	19M8328	2	Capscrew, M10 x 25	-
9	RE516553	1	Seal Kit	-
10	24-51003	1	Fuel Filter - Element only	-
	24-51004	1	Fuel Filter with Plastic Drain Valve	-
	24-51005	1	Fuel Filter with Metal Drain Valve	-
11	RE70358	1	Kit	-
12	RE60025	1	Fuel Line (includes key #21)	-
13	14M7298	1	Flange Nut, M8	-
14	T14050	1	Clamp	-
15	R116116	1	Bracket	-
16	19M7865	1	Screw, M8 x 16	-
17	RE60854	1	Valve & Vent Kit - Industrial only	-
18	RE70358	1	Filter Head Assembly	-
19	R56588	1	Strap	-
20	24M7096	2	Washer	-
21	R74012	2	Sealing Washer	-
22	24-51006	1	Drain Valve (Metal) Marine	-
	24-51002	1	Drain Valve (Plastic) Industrial	-

Fuel Filter and Fuel Lines

M1064T2, M65C2, NL1064T2, L1064A, M1064A, & NL1064H1

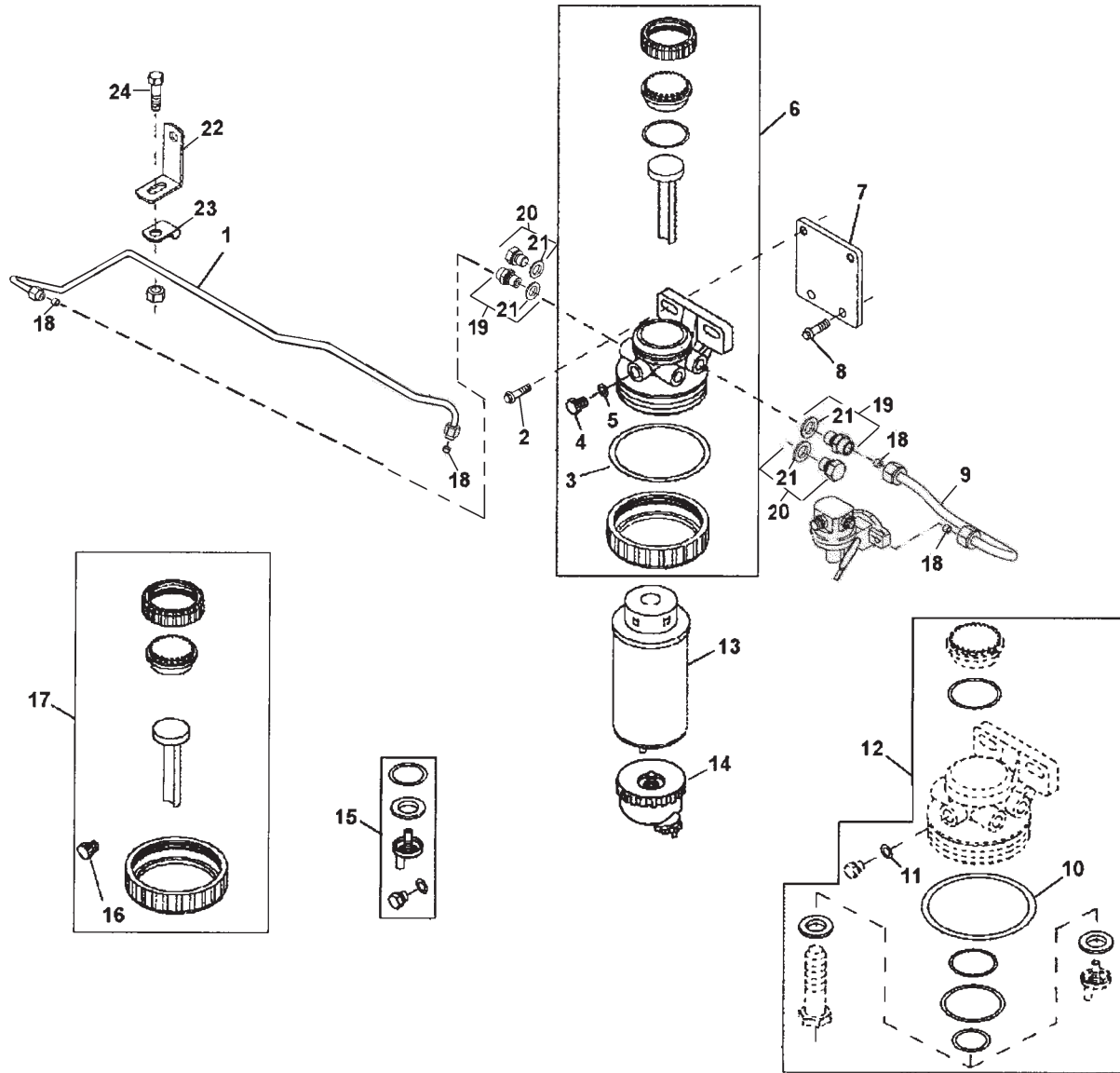

Fuel Filter and Fuel Lines

M1064T2, M65C2, NL1064T2, L1064A, M1064A, & NL1064H1

KEY	PART NUMBER	QTY	DESCRIPTION	SERIAL NUMBER
1	27-59405	1	Fuel Line, Injection Pump Inlet (M1064T2)	-
1	27-59409	1	Fuel Line, Injection Pump Inlet (L-M1064A)	-
1	RE515383	1	Fuel Line, Injection Pump Inlet (NL1064T2-H1)	-
2	19M7784	2	Screw	-
3	RE516553	1	Kit	-
4	R113563	1	Drain Plug	-
5	R113562	1	Seal Ring	-
6	RE509794	1	Filter Head Assembly (includes keys 3-5)	-
7	R505601	1	Bracket (NL1064T2-H1)	-
8	19M7784	2	Capscrew, Flanged Head M10 x 1.5 x 20 mm (NL1064T2-H1)	-
9	RE515360	1	Fuel Line, Filter Inlet (NL1064T2 - H1)	-
	27-59410	1	Fuel Line, Fuel Filter Inlet (L-M1064A)	-
	RE60037	1	Fuel Line, Filter Inlet (M1064T2 - M65C2)	-
10	R113565	1	Seal	-
11	16-59501	1	O-Ring	-
12	RE516512	1	Seal Kit (Set of 10 each)	-
13	RE509031	1	Filter Element	-
14	RE51650	1	Sediment Bowl, Transparent (Industrial only)	-
15	RE60854	1	Drain Valve Kit (Industrial only)	-
16	R113563	1	Drain Plug	-
17	RE526834	1	Repair Kit	-
18	R74012	**	Tube Seal	-
19	RE60029	2	Adapter (includes key 21)	-
20	RE46686	2	Plug (includes key 21)	-
21	51M7040	4	O-ring	-
22	R504859	1	Bracket (Industrial only)	-
23	T14050	1	Clamp	-
24	19M7784	1	Capscrew (Industrial only)	-

Fuel Filter and Fuel Lines

M1064H and NL1064H2

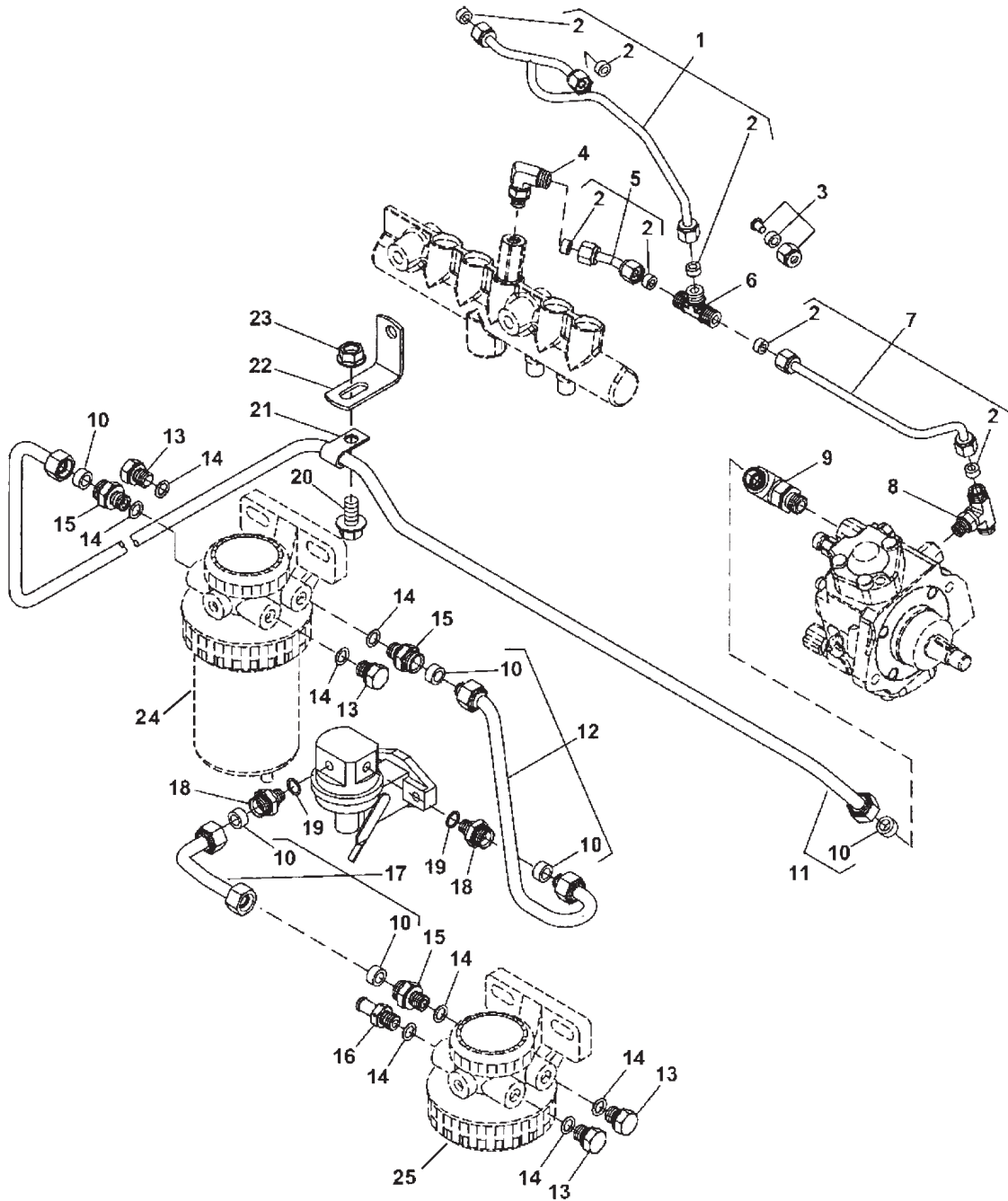

Fuel Filter and Fuel Lines

M1064H and NL1064H2

KEY	PART NUMBER	QTY	DESCRIPTION	SERIAL NUMBER
1	RE508892	1	Fuel Line	-
	R123593	1	Tube Nut	-
2	R51936	7	Seal	-
3	AR85519	3	Plug	-
4	RE502173	1	Adapter	-
5	RE515560	1	Tube Assembly	-
6	R97061	1	Tee Fitting	-
7	RE508893	1	Tube Assembly	-
8	RE502175	1	Fitting	-
9	RE502174	1	Elbow Fitting	-
10	R67092	6	Seal	-
11	RE517246	1	Tube Assembly, Final Fuel Filter Outlet (Industrial)	-
	27-59408	1	Tube Assembly, Final Fuel Filter Outlet (Marine)	-
12	RE517245	1	Tube Assembly, Fuel Pump Outlet	-
13	RE46686	4	Plug	-
14	51M7040	8	O-ring	-
15	RE60030	3	Fitting	-
16	RE500576	1	Male Connector M12 x 1.5 x 3/8" Hose Barb	-
17	RE517234	1	Tube Assembly, Fuel Pump Inlet	-
18	R516453	1	Adapter	-
19	R500271	2	O-ring	-
21	T13814	1	Clamp	-
22	R116116	1	Bracket	-
23	14M7296	1	Flange Nut	-
24		1	Secondary Fuel Filter - See parts detail	-
25		1	Primary Fuel Filter - See parts detail	-

GROUP 4 - FUEL SYSTEM

Fuel Supply & Return Connections

L - M1064D, T1, T2, M40C2, M55C2, M65C2

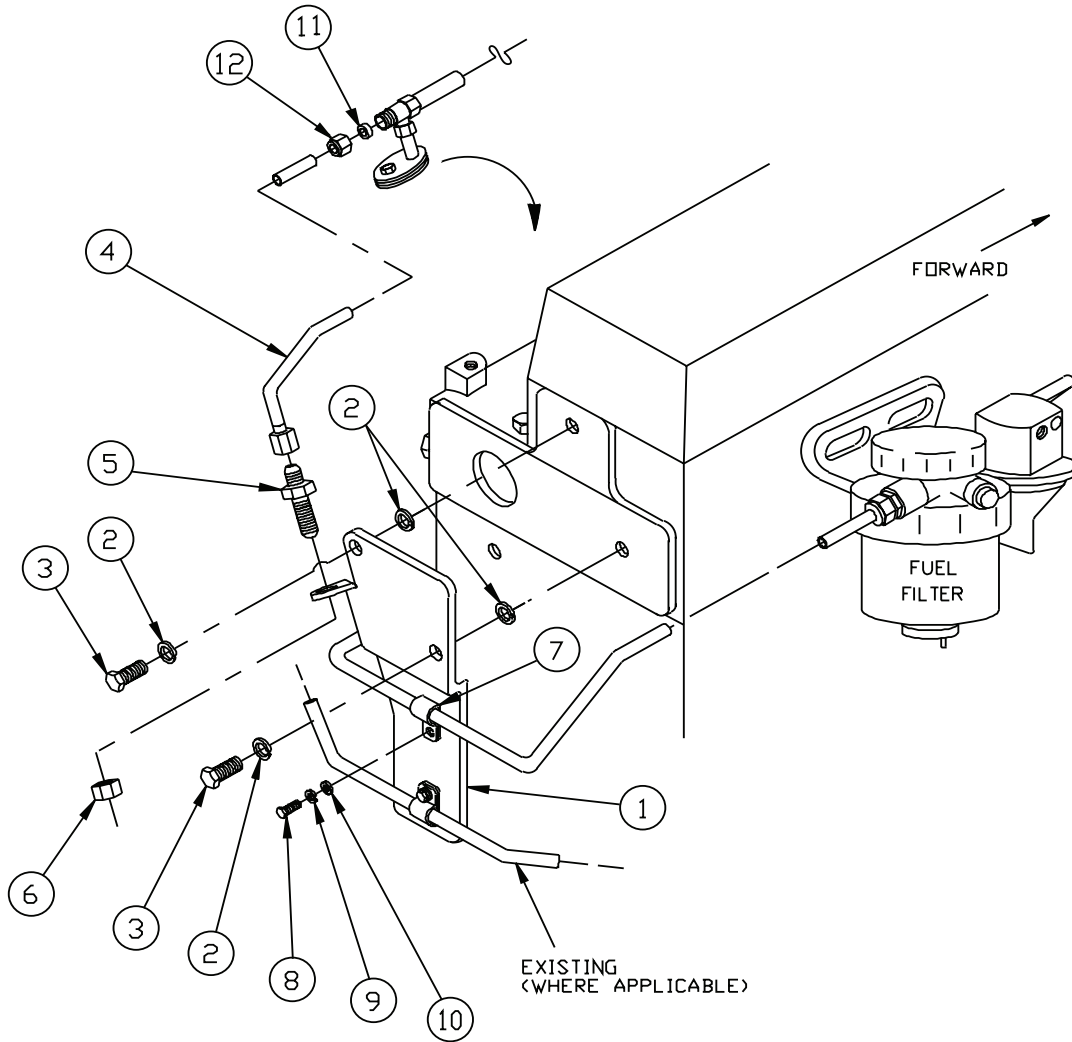

A-8507/ C-4210

KEY	PART NUMBER	QTY	DESCRIPTION	SERIAL NUMBER
1	23-09501	1	Bracket, Tube Support	-
2	15-00802	4	Lock Washer, Helical M10	-
3	12-00805	2	Capscrew, Hex Head M10 x 1.5 x 20 mm	-
4	27-59501	1	Tube Assembly, Fuel Return	-
	27-59513	1	Tube Assembly, Fuel Return (M1064T2 @ 1800 RPM only)	-
5	21-52211	1	Bulkhead Union, Steel 1/4-37T	-
6	14-00012	1	Bulkhead Nut, 7/16-20 (1/4-37T)	-
7	19-72252	1	Adelle Clamp 3/8" ID x 3/8" Stud	-
8	12-00751	1	Capscrew, Hex Head M8 x 1.25 x 16 mm	-
9	15-00702	1	Lock Washer, Helical M8	-
10	15-00701	1	Flat Washer M8	-
11	R51936	1	Tube Seal	-
12	R123593	1	Nut	-

Fuel Supply & Return Connections, Filter & Water Separator

M1064H

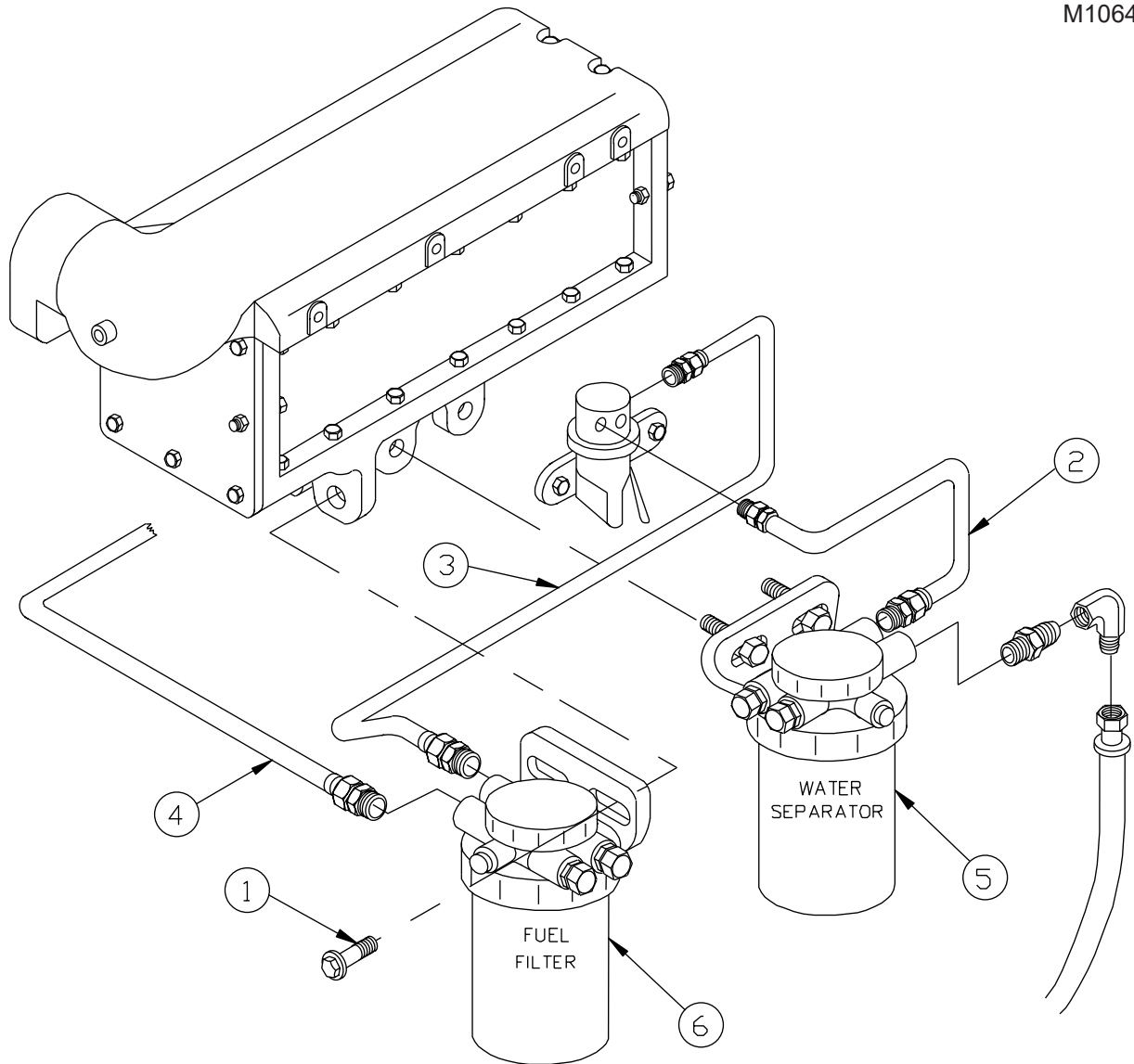

A-10374/ B-8698

KEY	PART NUMBER	QTY	DESCRIPTION	SERIAL NUMBER
1	12-80832	4	Capscrew, Hex Head Flanged M10 x 1.5 x 30 mm	-
2	27-59406	1	Tube Assembly, Fuel Lift Pump Inlet	-
3	27-59407	1	Tube Assembly, Fuel Lift Pump Outlet	-
4	27-59408	1	Tube Assembly, Final Fuel Filter Outlet	-
5		1	Water Separator	-
6		1	Fuel Filter	-
			} See parts detail	

Fuel Supply & Return Connections

L-M1064A

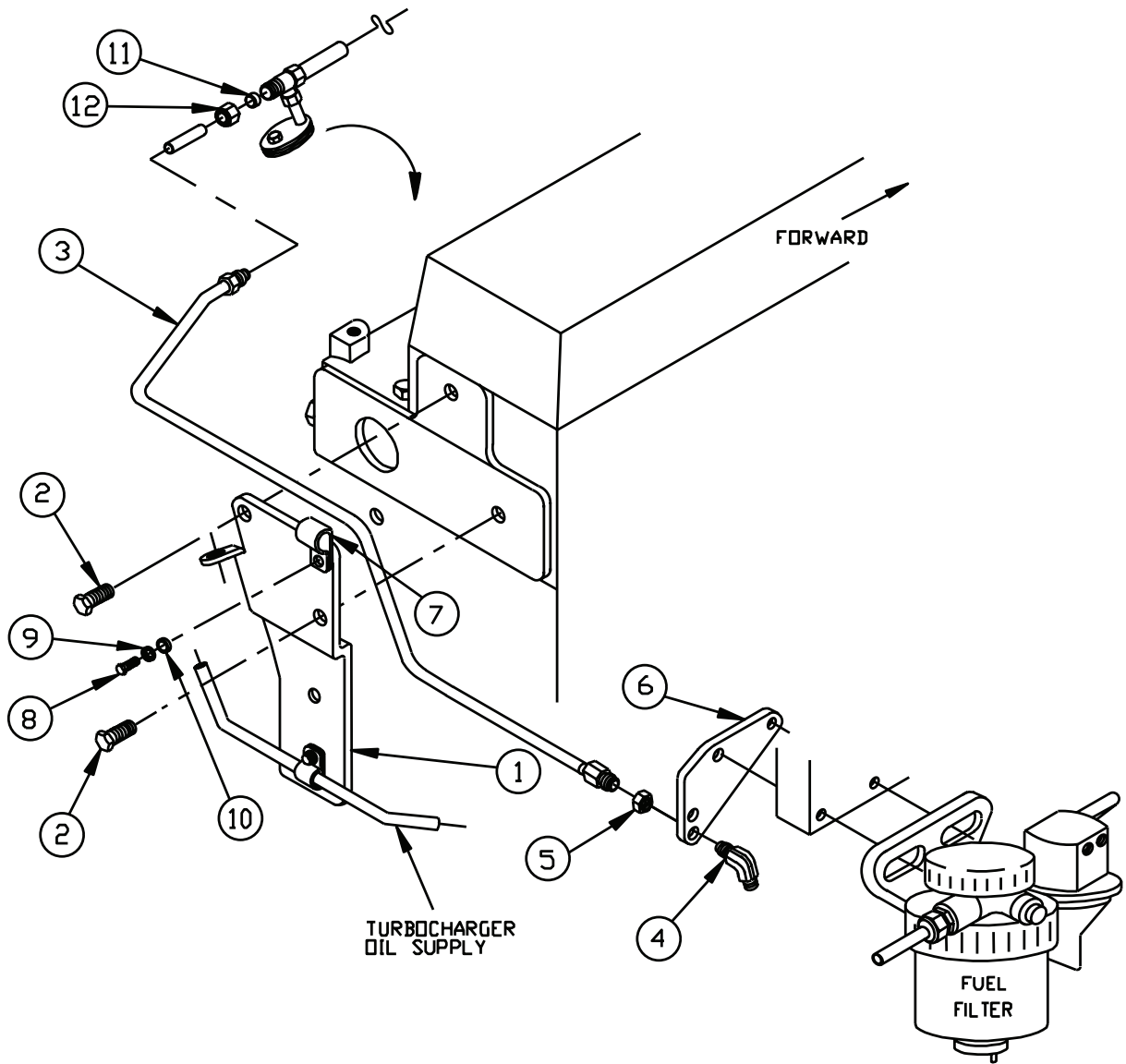

A-10684/ C-5693

KEY	PART NUMBER	QTY	DESCRIPTION	SERIAL NUMBER
1	23-09501	1	Bracket, Tube Support	-
2	19M7784	2	Capscrew, Hex Head Flanged, M10 x 1.5 x 20 mm	-
3	27-59411	1	Tube Assembly, Fuel Return	-
4	21-59512	1	Bulkhead Union, 45° Steel 1/4- 37T	-
5	14-00012	1	Bulkhead Nut, 7/16- 20 (1/4-37T)	-
6	23-59501	1	Bracket, Tube Support	-
7	19-72251	1	Adelle Clamp 1/4" ID x 3/8" Stud	-
8	12-00751	1	Capscrew, Hex Head M8 x 1.25 x 16 mm	-
9	15-00702	1	Lock Washer, Helical M8	-
10	15-00701	1	Flat Washer M8	-
11	R51936	1	Tube Seal	-
12	R123593	1	Nut	-

Fuel Supply & Return Connections

M1064H

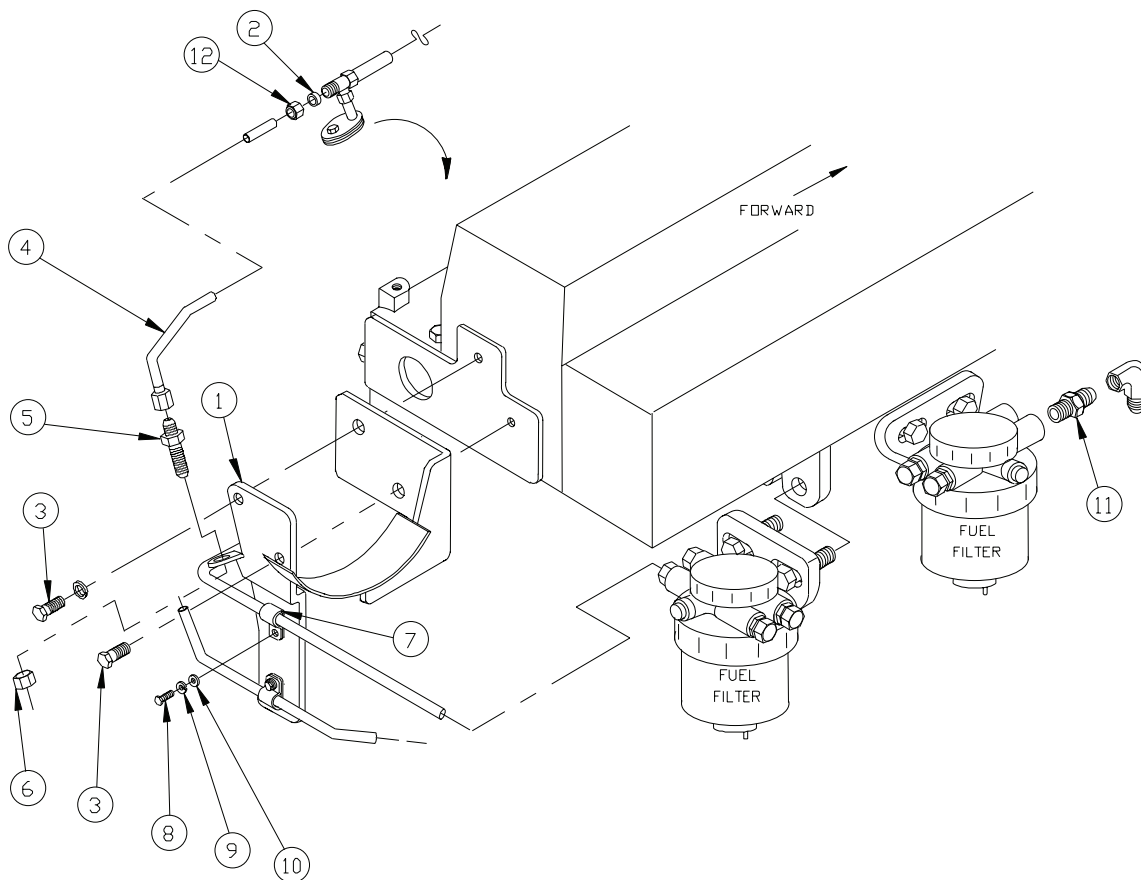

A-10683/ C-5804

KEY	PART NUMBER	QTY	DESCRIPTION	SERIAL NUMBER
1	23-09514	1	Bracket, Tube Support	-
2	R51936	1	Tube Seal	-
3	19M7786	2	Capscrew, Hex Head Flanged M10 x 1.5 x 30 mm	-
4	27-59503	1	Tube Assembly, Fuel Return	-
5	21-52211	1	Bulkhead Union, Steel 1/4-37T	-
6	14-00012	1	Bulkhead Nut, 7/16- 20 (1/4-37T)	-
7	19-72252	1	Adelle Clamp 3/8" ID x 3/8" Stud	-
8	12-00751	1	Capscrew, Hex Head M8 x 1.25 x 16 mm	-
9	15-00702	1	Lock Washer, Helical M8	-
10	15-00701	1	Flat Washer M8	-
11	21-59508	1	Male Connector, Steel 3/8- 37T x M12 x 1.5	-
12	R123593	1	Tube Nut	-

GROUP 4 - FUEL SYSTEM

Primary Fuel Filter

M1064H & NL1064H2

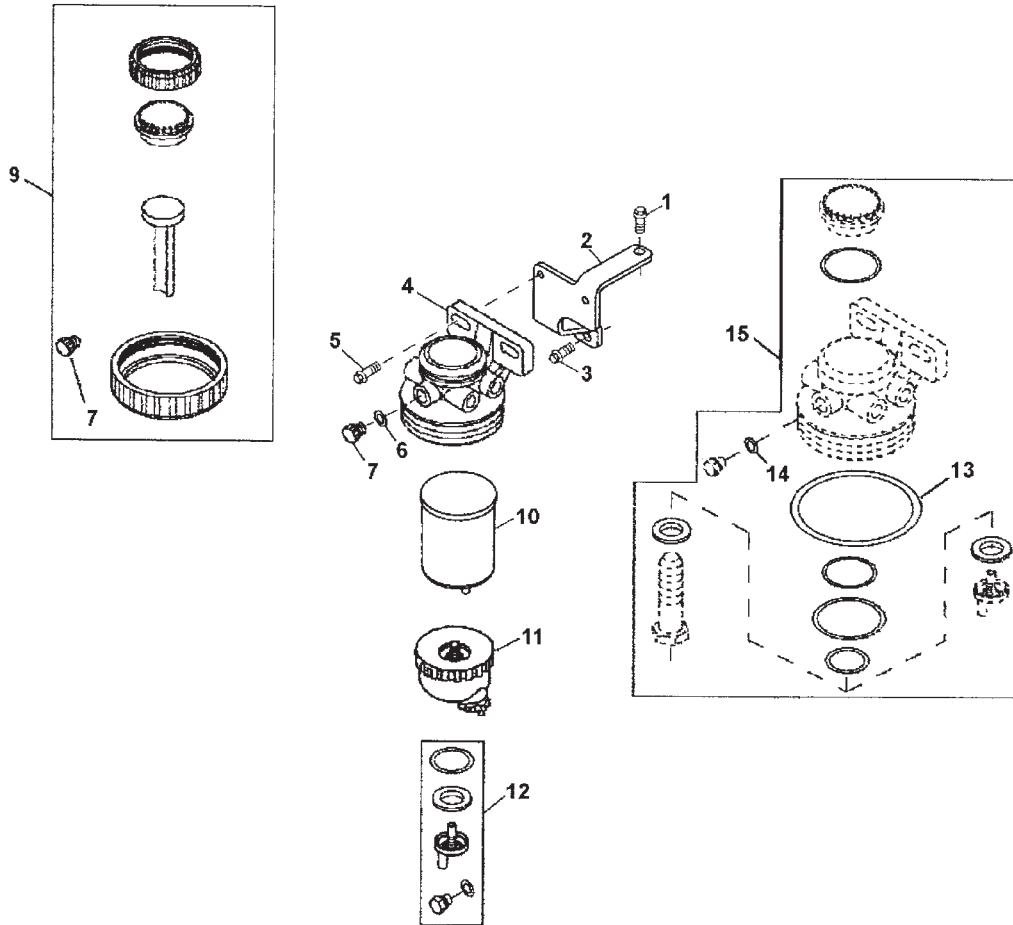

Reproduced by permission of Deere & Co., c2005. Deere & Company. All rights reserved.

RGF8376

KEY	PART NUMBER	QTY	DESCRIPTION	SERIAL NUMBER
1	19M7807	2	Capscrew, M10 x 60 mm	-
2	R516532	1	Bracket (not as shown)	-
3	19M7786	1	Capscrew, M10 x 30 mm	-
4	RE508847	1	Filter Head	-
5	19M7785	2	Screw	-
	28H1497	1	Bushing	-
6	R113562	1	Ring	-
7	R113563	2	Drain Plug	-
9	RE51649	1	Seal Kit	-
10	RE509208	1	Fuel Filter (Former # RE517181)	-
11	RE51650	1	Sediment Bowl (Industrial only)	-
12	RE60854	1	Drain Valve (Industrial only)	-
	24-51006	1	Drain Valve, Metal (USCG)	-
13	RE516512	1	O-ring	-
14	R113562	1	Ring	-
15	RE516553	1	Seal Kit	-

Secondary Fuel Filter

M1064H & NL1064H2

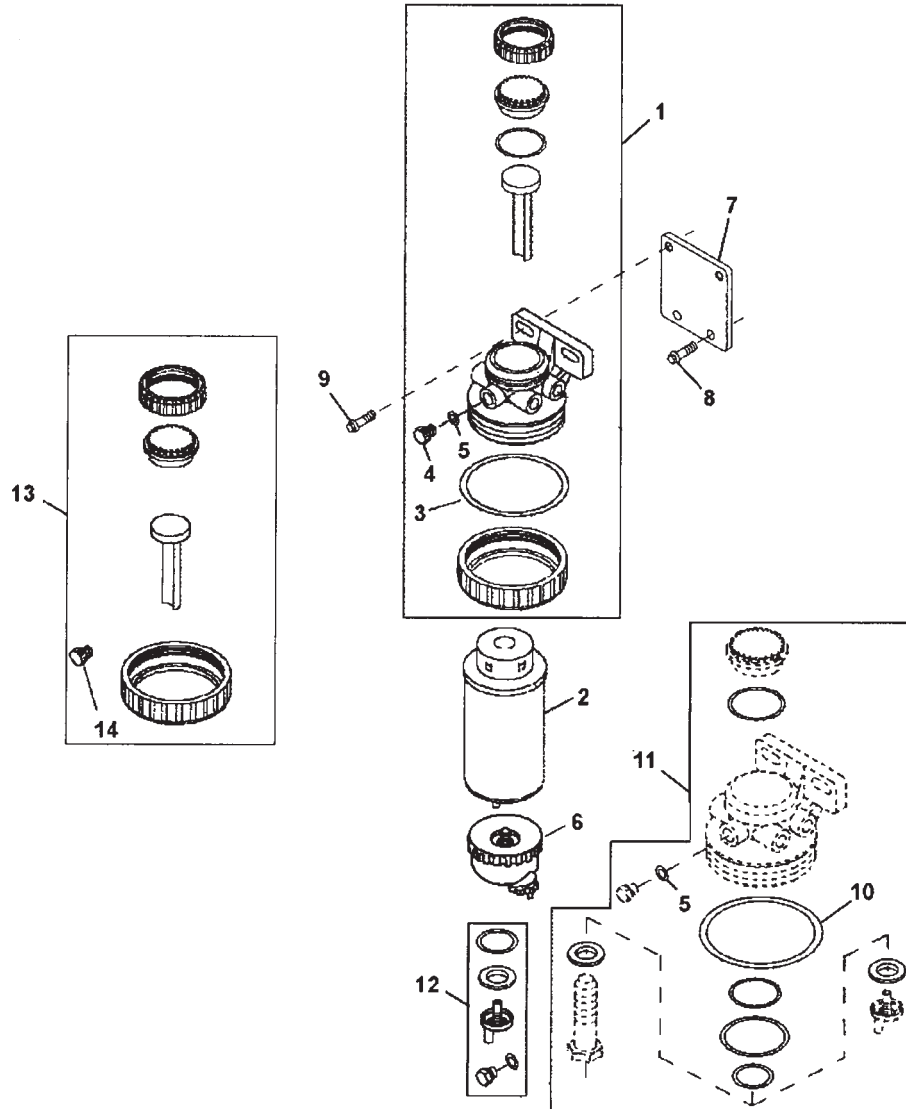

Reproduced by permission of Deere & Co., c2005. Deere & Company. All rights reserved.

RGF8265z

KEY	PART NUMBER	QTY	DESCRIPTION	SERIAL NUMBER
1	RE509794	1	Filter Head Kit (includes keys 3,4,5)	-
2	RE509031	1	Filter Element	-
3	RE516553	1	Seal Kit	-
4	R113563	1	Vent Plug	-
5	R113562	1	O-ring	-
6	RE51650	1	Transparent Sediment Bowl (Industrial only)	-
7	R516437	1	Bracket (Industrial only)	-
8		1	Capscrew	-
9		1	Capscrew	-
10		1	O-ring (not available separately)	-
11	RE516512	1	Filter Head Mounting Kit (includes keys 5 & 10)	-
12	RE60854	1	Fuel Filter Drain Kit (Industrial only)	-
	24-51006	1	Drain Valve, Metal (USCG)	-
13	RE51649	1	Seal Kit	-
14	R113563	1	Vent Plug	-

Fuel Filter Bypass

M1064D, T1, T2, M40C2, M55C2, & M65C2

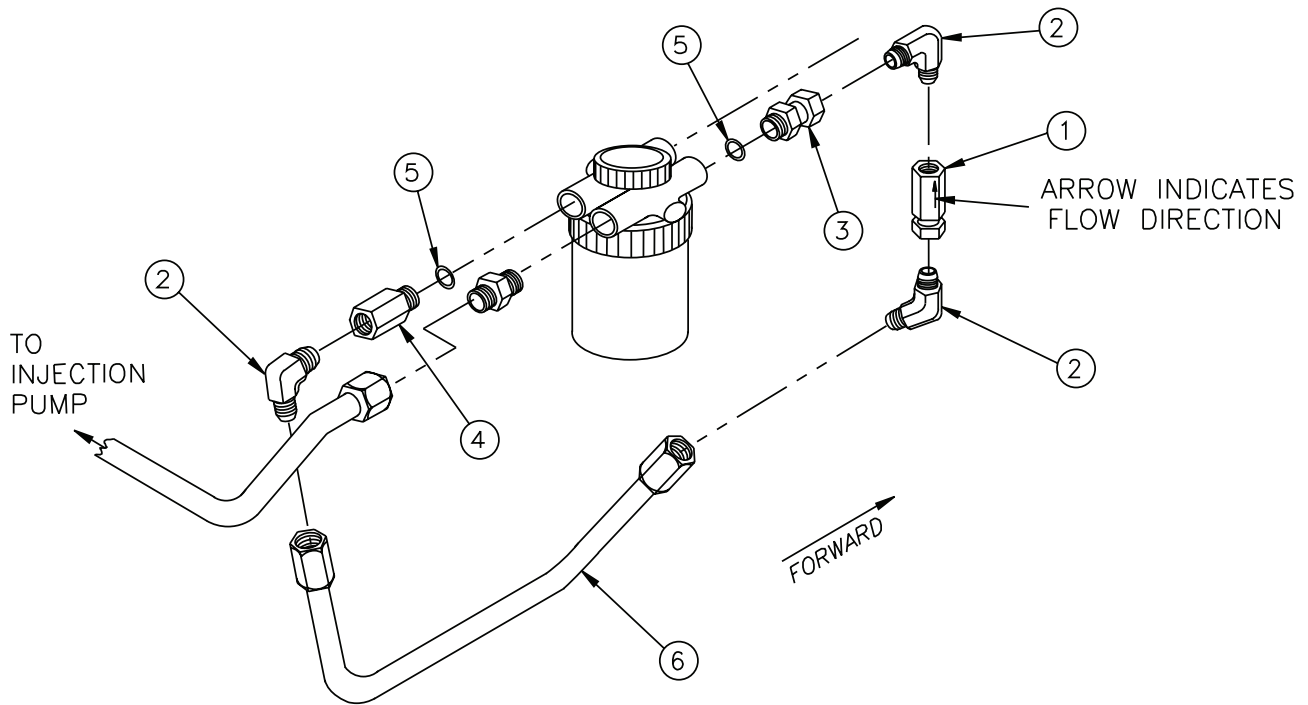

A-9903/ B-9164

KEY	PART NUMBER	QTY	DESCRIPTION	SERIAL NUMBER
1	36-70018	1	Check Valve, Steel 1/4 NPSF	-
2	21-74411	3	Male Elbow, 90° Steel 1/4 NPT x 5/16- 37T	-
3	21-59506	1	Female Swivel, Steel M12 x 1.5 x 5/16- 37T	-
4	21-60022	1	Female Adapter, Steel 1/4 NPT x M12 x 1.5	-
5	51M7040	2	O-ring	-
6	27-59502	1	Tube Assembly, Fuel Filter Bypass	-

Fuel Filter Bypass

M1064H

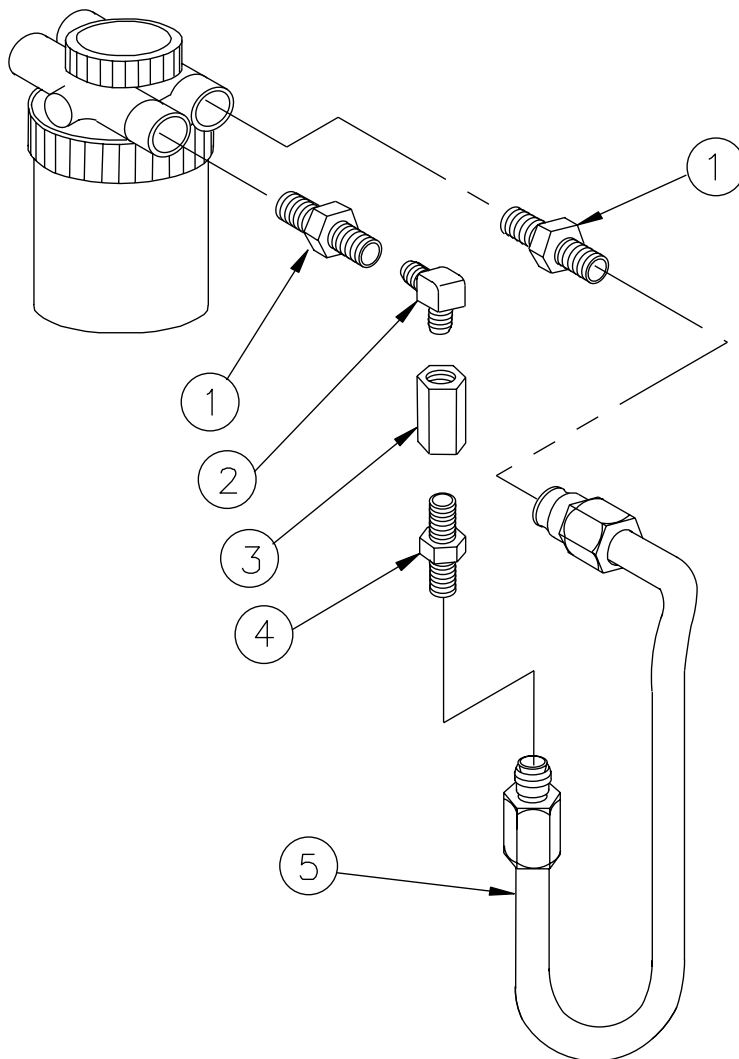

A-11161/ A-11268

KEY	PART NUMBER	QTY	DESCRIPTION	SERIAL NUMBER
1	21-59508	2	Male Connector, Steel 3/8- 37T x M12 x 1.5	-
2	21-59522	1	Elbow, 90° Swivel, Steel 3/8- 37T x 1/4 NPT	-
3	36-70018	1	Check Valve, Steel 1/4 NPSF	-
4	21-00612	1	Male Connector, Steel 1/4 NPT x 3/8- 37T	-
5	27-59510	1	Tube Assembly, Fuel Filter Bypass	-
	21-60041	1	Male Connector, S/S M10 x 1.0 x 3/8-37T	-
	07005-01012	1	Sealing Washer	-
	18-59410	1	Hose Assembly 5/16" ID x 27"	-
				} for Fuel Pump Inlet, not shown

GROUP 4 - FUEL SYSTEM

Manual Fuel Filter Bypass Valve

M1064D-T1--T2

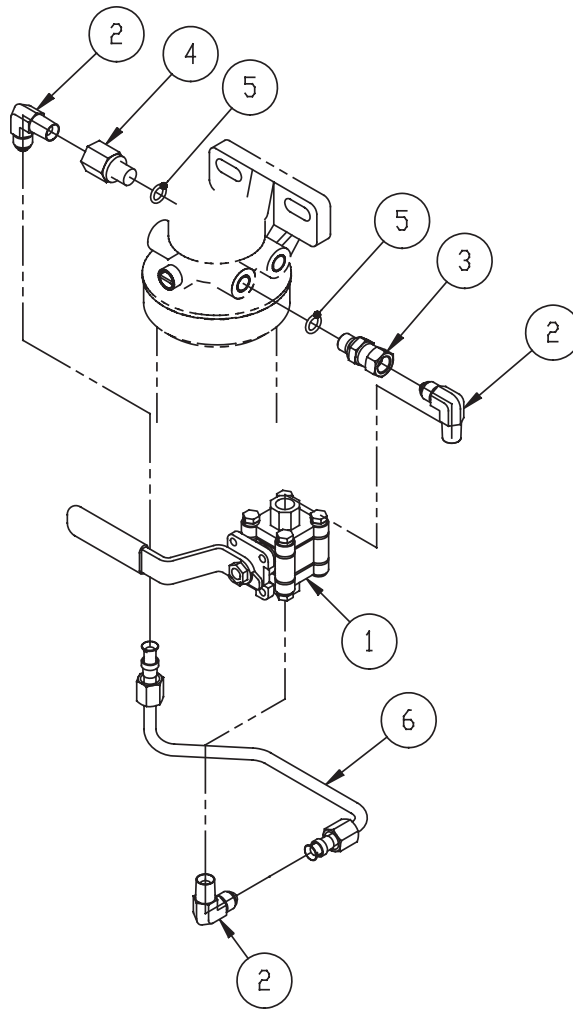

B-10157

KEY	PART NUMBER	QTY	DESCRIPTION	SERIAL NUMBER
1	36-50004	1	Ball Valve,S/S (316) 1/4NPT Fire-Safe	-
2	21-74411	3	Male Elbow .90, Steel 1/4NPT X 5/16-37T	-
3	21-59506	1	Female Swivel, Steel. M12x1.5 X 5/16-37T	-
4	21-60022	1	Female Adapter, Steel 1/4NPT X M12x1.5	-
5	51M7040	2	O-Ring 9.3mm ID X 2.2mm 90 Durometer Nitrile	-
6	27-59514	1	Tube Assembly, Fuel Filter Bypass	-
7	21-60009	1	Female Adapter, Steel 1/8 NPT X M10 x 1.0	-
8	21-71055	1	Male Elbow 90,Steel 1/8 NPT X 3/8-37 T	-

Fuel Transfer Pump

L-M-NL1064D, M-NL1064T1, T2, L-M1064A, M40C2, M55C2, and M65C2

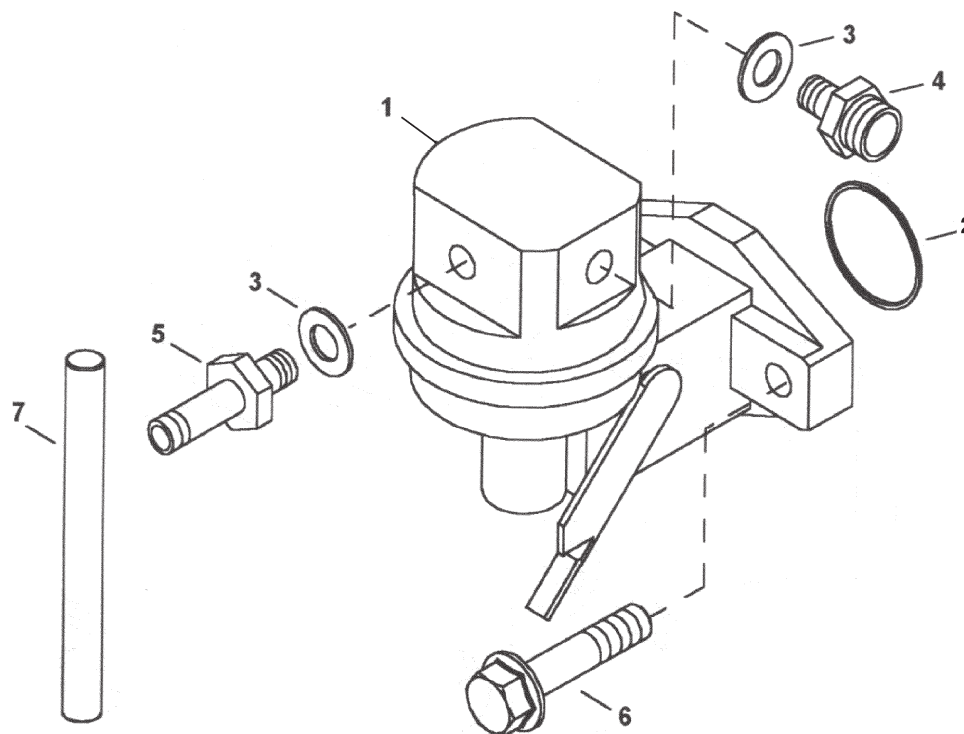

Reproduced by permission of Deere & Co., c2005. Deere & Company. All rights reserved.

RGP8272

KEY	PART NUMBER	QTY	DESCRIPTION	SERIAL NUMBER
1	RE68345	1	Fuel Pump (includes keys 1-5, & 7)	-
2	R123273	1	O-ring	-
3	R500271	2	O-ring	-
4	R500270	1	Male Connector, M10 x 1.0 x 5/16" Compression	-
5	R500269	1	Male Connector, M10 x 1.0 x 5/16" Hose Barb (Industrial Only)	-
	21-60009	**	Female Adapter, Steel 1/8 NPT x M10 x 1.0	-
	21-60041	**	Male Connector S/S M10 x 1.0 x 3/8.37 T	-
6	RE504233	2	Screw	-
7	R133405	1	Push Rod	-
			** As required by application	

GROUP 4 - FUEL SYSTEM

Fuel Transfer Pump

M1064H & NL1064H2

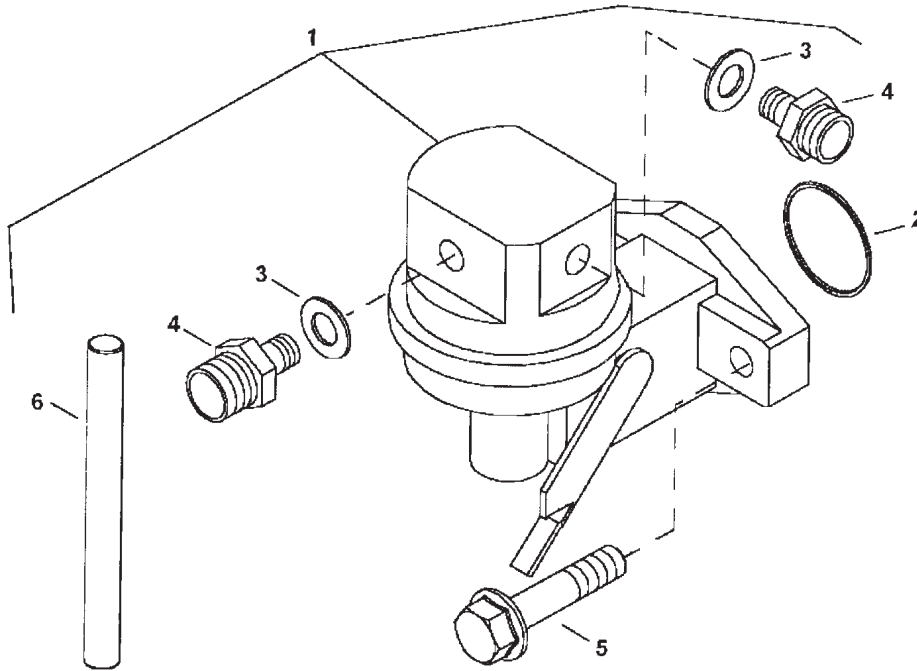

Reproduced by permission of Deere & Co., c2005. Deere & Company. All rights reserved.

RG8271

KEY	PART NUMBER	QTY	DESCRIPTION	SERIAL NUMBER
1	RE517230	1	Fuel Pump (includes keys 2 -6)	-
2	R123273	1	O-ring	-
3	R500271	2	O-ring	-
	07005-01012	1	Sealing Washer *	
4	R516453	2	Male Connector, Brass M10 x 1.0 x 3/8 Compression	-
	21-60041	1	Male Connector S/S M10 x 1.0 x 3/8-37T *	
5	R504233	2	Screw	-
6	R133405	1	Push Rod	-
			* Used only with fuel filter bypass kit - See assembly detail.	

Throttle Assembly

L1064D- T1

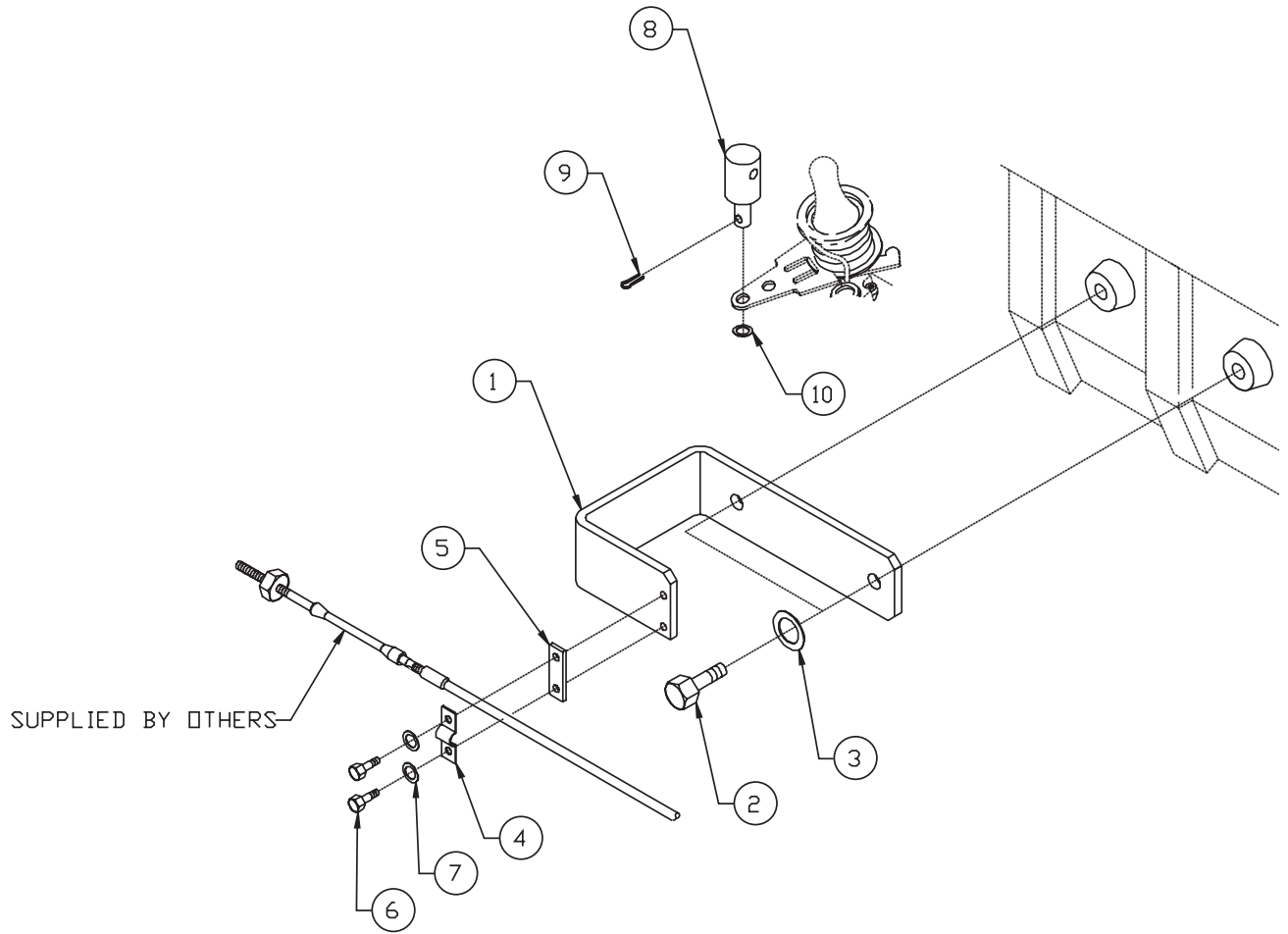

A-8977/ B-6142

KEY	PART NUMBER	QTY	DESCRIPTION	SERIAL NUMBER
1	23-99401	1	Bracket, Throttle Connection	-
2	12-00831	2	Capscrew, Hex Head, M10 x 1.5 x 25 mm	-
3	15-00804	2	Wave Washer, M10	-
4	23-91001	1	Cable Clamp	-
5	23-91002	1	Clamp Shim	-
6	12-00000	2	Machined Screw, BH Slotted, #10-32 x 1/2"	-
7	15-00033	2	Lock Washer, Helical #10	-
8	23-91003	1	Throttle Pivot	-
9	00-54801	1	Cotter Pin	-
10	15-01134	3	Flat Washer, M6 S/S	-

Electrical System 12V & 24V Standard Ground

L1064D- T1

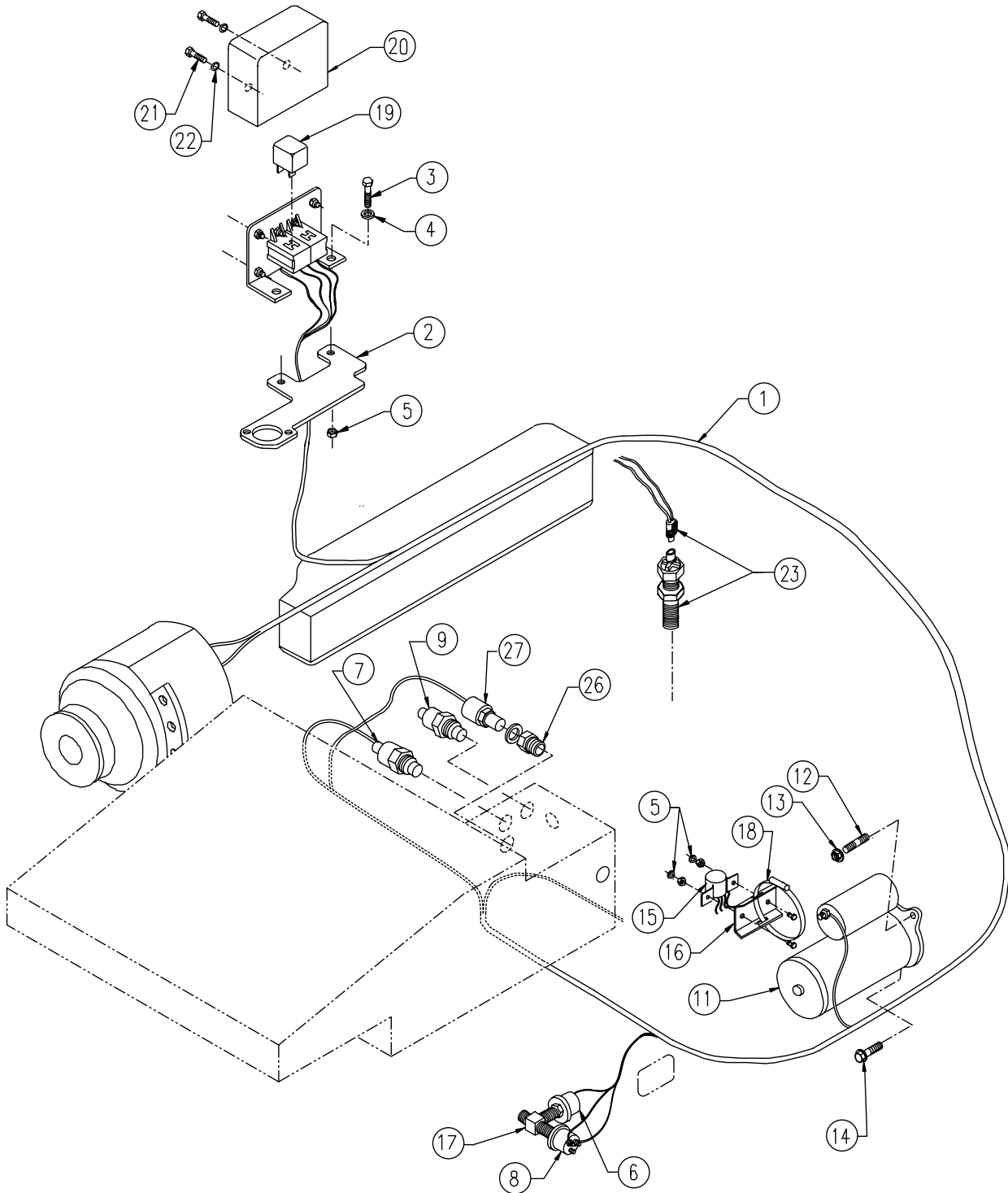

A-8802, A-8880/ C-5907

Electrical System 12V & 24V Standard Ground

L1064D- T1

KEY	PART NUMBER	QTY	DESCRIPTION	SERIAL NUMBER
1	22-49402	1	Engine Wire Harness (see parts detail)	-
2	23-49507	1	Bracket, Circuit Breaker & Relay	-
3	12-00111	2	Capscrew, Hex Head 1/4- 20 x 3/4"	-
4	15-00121	4	Flat Washer, 1/4"	-
5	14-00112	4	Hex Nut Nylock 1/4-20	-
6	22-41016	1	Pressure Sender, 0-80 PSI 1/8 NPT	-
7	22-41026	1	Temperature Sender, 250°F 1/2 NPT	-
8	22-40233	1	Oil Pressure Switch, 15 PSI 1/8 NPT	-
9	22-40920	1	Temperature Switch 205°F 1/2 NPT	-
11	RE68470	1	Starter 12 Volt Standard Ground	-
	22-41414	1	Starter 24 Volt Isolated Ground	-
12	13-05001	1	Stud, M10 x 1.5 x 25 mm	-
13	14-80811	1	Hex Nut, Flanged, M10 x 1.5	-
14	12-80832	1	Capscrew, Hex Head Flanged M10 x 1.5 x 30 mm	-
15	22-41080	1	Solenoid, 12V DC 65 Amp	-
	22-41079	1	Solenoid, 24V DC 65 Amp	-
16	23-40009	1	Bracket, Solenoid Mounting	-
17	21-05400	1	Street Tee, Steel 1/8 NPT	-
18	19-00060	1	Hose Clamp #60	-
19	22-42047	2	Relay, SPDT 12 Volt DC 50 Amp	-
	22-40085	2	Relay, SPDT 24 Volt DC 20 Amp	-
20	00-44801	1	Cover, Circuit Breaker & Relays	-
21	12-00015	2	Machine Screw #10- 32 x 3/8"	-
22	15-70002	2	Flat Washer #10	-
23	22-40440	1	Magnetic Pick-up	-
24	22-99400	1	Main Instrument Panel 12 Volt	} see parts detail, not shown
	22-99415	1	Main Instrument Panel 24 Volt	
25	22-41002	1	20' Wire Harness Extension, not shown	-
26	21-09601	1	Bushing, Steel	-
27	RE503242	1	Temperature Switch	-

Electrical System 12 & 24 Volt Isolated Ground

L1064D- T1

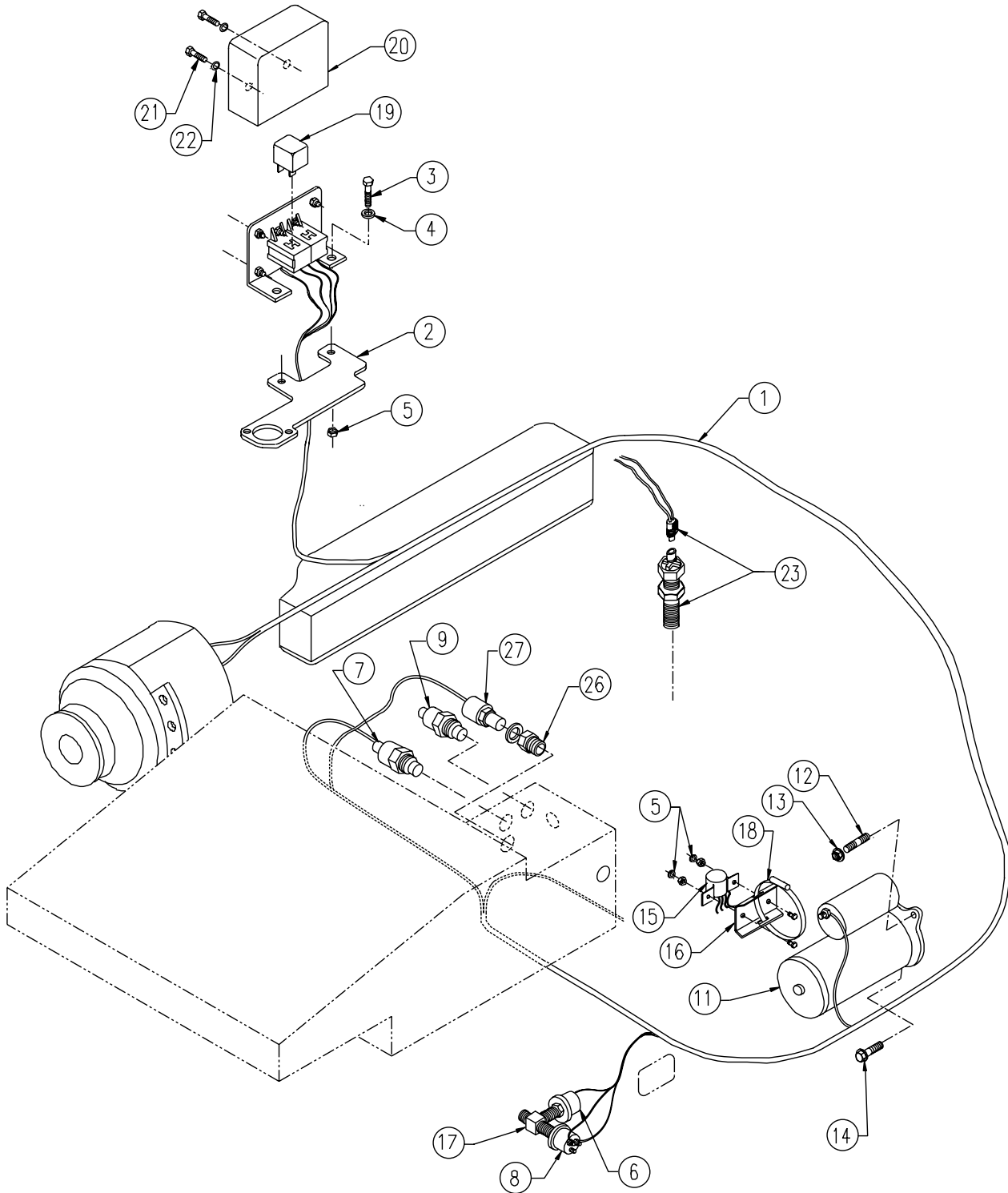

A-8879, A-8881/ C-5907

Electrical System 12 & 24 Volt Isolated Ground

L1064D- T1

KEY	PART NUMBER	QTY	DESCRIPTION	SERIAL NUMBER
1	22-49402	1	Engine Wire Harness (see parts detail)	-
2	23-49507	1	Bracket, Circuit Breaker & Relay	-
3	12-00111	2	Capscrew, Hex Head 1/4- 20 x 3/4"	-
4	15-00121	4	Flat Washer 1/4"	-
5	14-00112	4	Hex Nut Nylock 1/4- 20	-
6	22-42803	1	Pressure Sender, 0-80 PSI 1/8 NPT	-
7	22-42802	1	Temperature Sender, 250°F 1/2 NPT	-
8	22-40236	1	Oil Pressure Switch, 15 PSI 1/8 NPT	-
9	22-40921	1	Temperature Switch 205°F 1/2 NPT	-
11	22-41078	1	Starter 12 Volt Isolated Ground	-
	22-41414	1	Starter 24 Volt Isolated Ground	-
12	13-05001	1	Stud, M10 x 1.5 x 25 mm	-
13	14-80811	1	Hex Nut, Flanged, M10 x 1.5	-
14	12-80832	1	Capscrew, Hex Head Flanged M10 x 1.5 x 30 mm	-
15	22-41080	1	Solenoid, 12V DC 65 Amp	-
	22-41079	1	Solenoid, 24V DC 65 Amp	-
16	23-40009	1	Bracket, Solenoid Mounting	-
17	21-05400	1	Street Tee, Steel 1/8 NPT	-
18	19-00060	1	Hose Clamp #60	-
19	22-42047	2	Relay, SPDT 12 Volt 50 Amp	-
	22-40085	2	Relay, SPDT 24 Volt 20 Amp	-
20	00-44801	1	Cover, Circuit Breaker & Relays	-
21	12-00015	2	Machine Screw #10- 32 x 3/8"	-
22	15-70002	2	Flat Washer #10	-
23	22-40440	1	Magnetic Pick-up	-
24	22-99400	1	Main Instrument Panel 12 Volt	} see parts detail, not shown
	22-99415	1	Main Instrument Panel 24 Volt	
25	22-41002	1	20' Wire Harness Extension, not shown	-
26	21-09601	1	Bushing, Steel	-
27	RE503242	1	Temperature Switch	-

Electrical System 12 & 24 Volt Standard Ground

L1064A

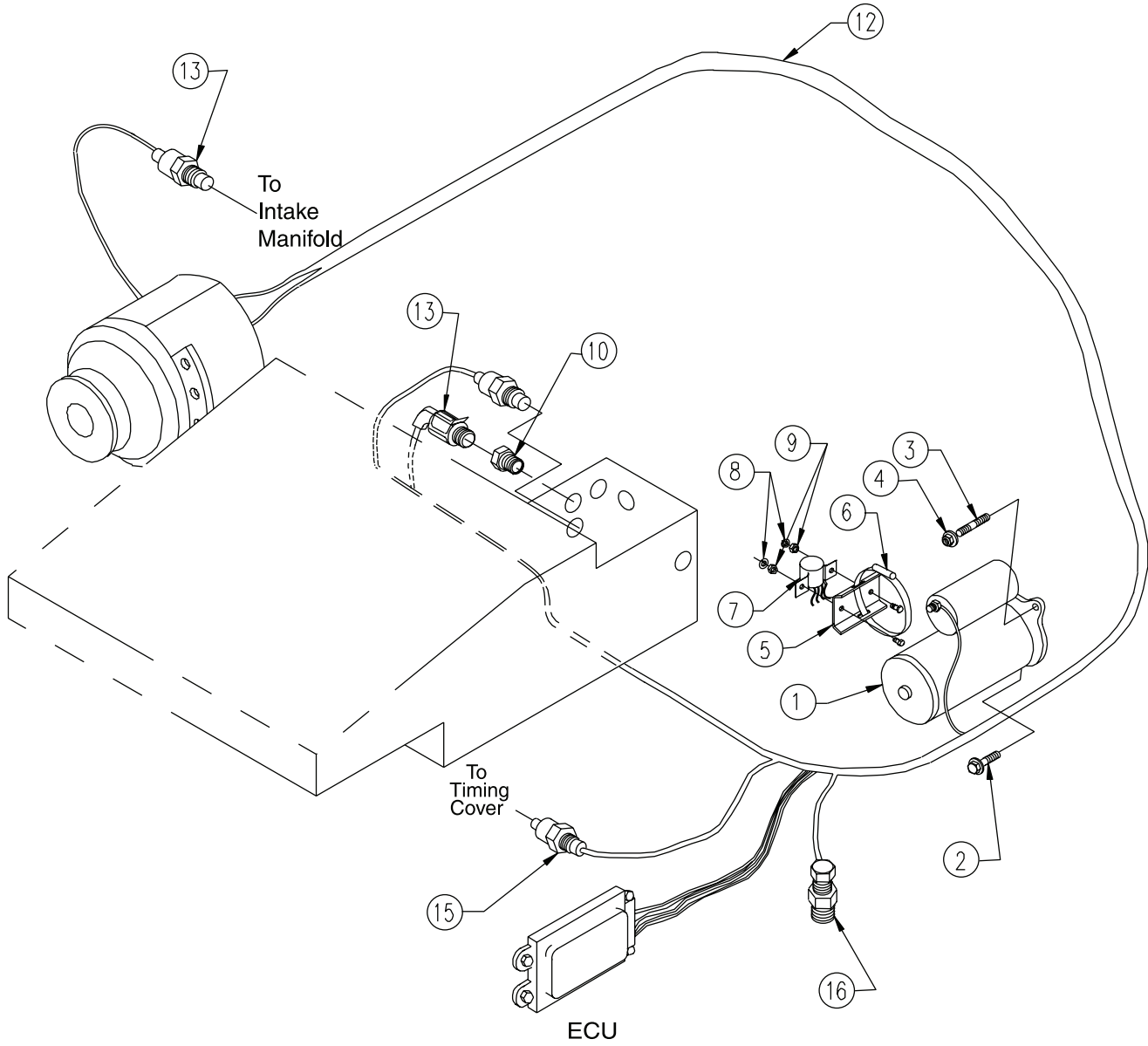

A-10486, A-10488/ B-8787

Electrical System 12 & 24 Volt Standard Ground

L1064A

KEY	PART NUMBER	QTY	DESCRIPTION	SERIAL NUMBER
1	RE68470	1	Starter (12 Volt Standard Ground)	-
	22-41414	1	Starter (24 Volt Isolated Ground)	-
2	12-80832	1	Capscrew, Hex Head Flanged M10 x 1.5 x 30 mm Grade 8.8	-
3	13-05001	1	Stud, M10 x 1.5 x 25 mm (37 mm LOA)	-
4	14-80811	1	Hex Nut, Flanged M10 x 1.5	-
5	23-40009	1	Bracket, Solenoid Mtg.	-
6	19-00060	1	Hose Clamp #60	-
7	22-41080	1	Solenoid 12 VDC 65 Amp	-
	22-41079	1	Solenoid 24 VDC 65 Amp	-
8	14-00112	2	Hex Nut, Nylock 1/4-20	-
9	15-00121	2	Flat Washer 1/4" SAE	-
10	21-09601	1	Bushing, Steel 1/2 NPT x M14 x 1.5	-
11	AT157679	1	Transient Voltage Protector 12V (not shown)	-
	AT163022	1	Transient Voltage Protector 24V (not shown)	-
12	22-49513	1	Engine Wire Harness Assembly	-
13	RE52722	1	Sensor, Coolant Temperature	-
14	RE61812	1	Sensor, Air Temperature	-
15	RE519144	1	Speed Sensor	-
16	RE167207	1	Sensor, Oil & Fuel Pressure	-

Electrical System 12 & 24 Volt Isolated Ground

L1064A

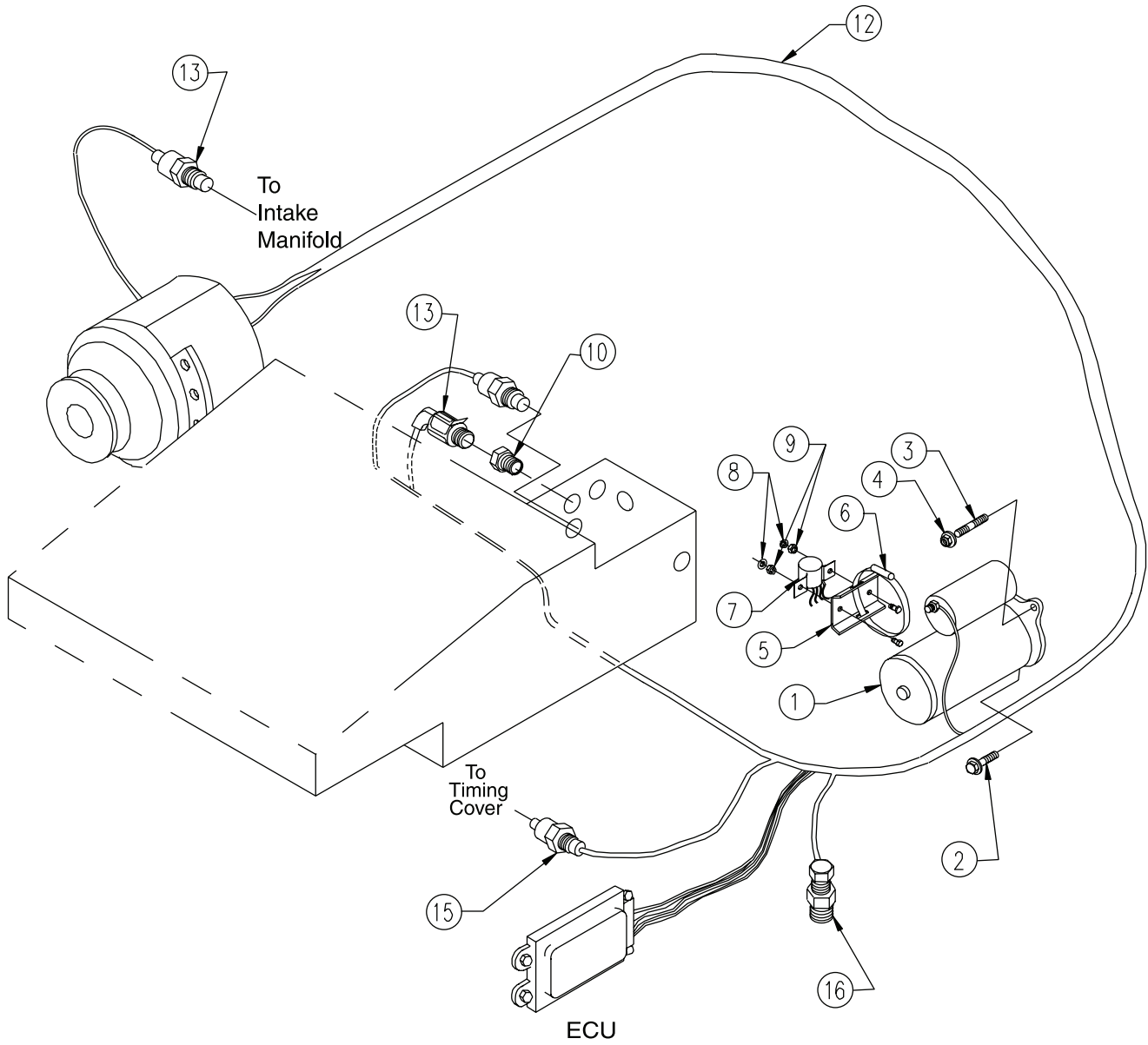

A-10487, A-10489/ B-8787

Electrical System 12 & 24 Volt Isolated Ground

L1064A

KEY	PART NUMBER	QTY	DESCRIPTION	SERIAL NUMBER
1	22-41078	1	Starter (12 Volt Isolated Ground)	-
	22-41414	1	Starter (24 Volt Isolated Ground)	-
2	12-80832	1	Capscrew, Hex Head Flanged M10 x 1.5 x 30 mm Grade 8.8	-
3	13-05001	1	Stud, M10 x 1.5 x 25 mm (37 mm LOA)	-
4	14-80811	1	Hex Nut, Flanged M10 x 1.5	-
5	23-40009	1	Bracket, Solenoid Mtg.	-
6	19-00060	1	Hose Clamp #60	-
7	22-41080	1	Solenoid 12 VDC 65 Amp	-
	22-41079	1	Solenoid 24 VDC 65 Amp	-
8	14-00112	2	Hex Nut, Nylock 1/4-20	-
9	15-00121	2	Flat Washer 1/4" SAE	-
10	21-09601	1	Bushing, Steel 1/2 NPT x M14 x 1.5	-
11	AT157679	1	Transient Voltage Protector 12V (not shown)	-
	AT163022	1	Transient Voltage Protector 24V (not shown)	-
12	22-49513	1	Engine Wire Harness Assembly	-
13	RE52722	1	Sensor, Coolant Temperature	-
14	RE61812	1	Sensor, Air Temperature	-
15	RE519144	1	Speed Sensor	-
16	RE167207	1	Sensor, Oil & Fuel Pressure	-

Electrical System 12V Standard Ground

M1064D - T1, M40C2, and M55C2

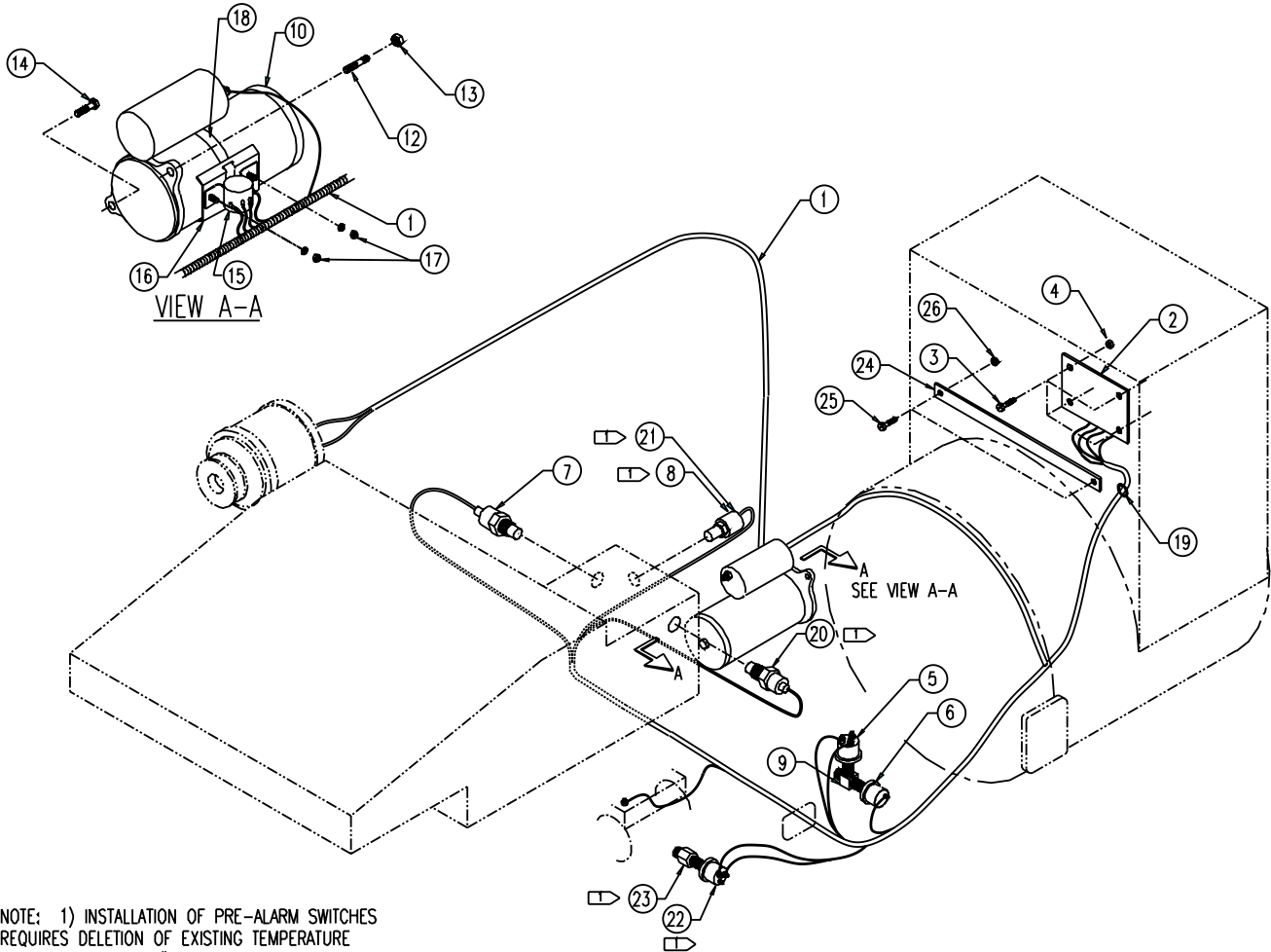

NOTE: 1) INSTALLATION OF PRE-ALARM SWITCHES
REQUIRES DELETION OF EXISTING TEMPERATURE
SHUT-DOWN SWITCH #8. INSTALL NEW TEMPERATURE
SWITCH #20, TEMPERATURE PRE-ALARM SWITCH #21
& PRESSURE PRE-ALARM SWITCH #22(+ ADAPTER #23)
AS SHOWN.

A-8363/ C-4471

Electrical System 12V Standard Ground

M1064D - T1, M40C2, and M55C2

KEY	PART NUMBER	QTY	DESCRIPTION	Serial Number
1	22-49401	1	Engine Wire Harness, (Standard Ground)	-
2	22-70083	1	Relay Board Assembly, 12 volt (see Parts Detail)	-
	22-70086	1	Relay Board Assembly, 12 volt (Autostart units - see Parts Detail)	-
3	12-00001	4	Machine Screw, BH Slotted #10-32 x 3/4" S/S	-
4	14-00006	4	Hex Nut, Nylock #10-32	-
5	22-40915	1	Pressure Switch, 15 PSI, 1/8 NPT	-
6	22-41016	1	Pressure Sender, 0-80 PSI, (Standard Ground 1/8 NPT, Single Station)	-
	22-71016	1	Pressure Sender, 0-80 PSI, (Standard Ground 1/8 NPT, Dual Station)	-
7	22-41026	1	Temperature Sender, 250°F, (Standard Ground 1/2 NPT, Single Station)	-
	22-71026	1	Temperature Sender 250°F, (Standard Ground 1/4 NPT, Dual Station)	-
8	22-40907	1	Temperature Switch, 205°F, (3/8 NPT, replaced by #20 when equipped with pre-alarm option)	-
9	21-05400	1	Street Tee, Steel, 1/8 NPT	-
10	RE68470	1	Starter, 12V Standard Ground	-
12	13-05001	1	Stud, M10 x 1.5 x 25 mm	-
13	14-80811	1	Hex Nut, Flanged, M10 x 1.5	-
14	12-80832	1	Cap Screw, Hex Head, Flanged, M10 x 1.5 x 30 mm	-
15	22-41080	1	Solenoid, 12V DC 65 amp, N.O. Isolated Ground	-
16	23-40009	1	Bracket, Solenoid Mounting	-
17	14-00112	2	Hex Nut, Nylock, 1/4-20	-
18	19-00060	1	Hose Clamp #60	-
19	00-40028	1	Grommet	-
20	22-40904	1	Temperature Switch, 205°F (with Pre-alarm option)	-
21	22-40910	1	Temperature Switch, 195°F (with Pre-alarm option)	-
22	22-40901	1	Pressure Switch, 25 PSI (with Pre-alarm option)	-
23	21-00023	1	Adapter 1/8 NPT (with Pre-alarm option)	-
24	22-41077	1	Terminal Strip (with Pre-alarm option)	-
25	21-00135	1	Bushing, Brass 1/2 NPT x 1/4 NPT (for #7 22-71026)	-
			Note: Solenoid Part # RE503633 for Starter RE502214	

Electrical System 12V Isolated Ground

M1064D - T1, M40C2, & M55C2

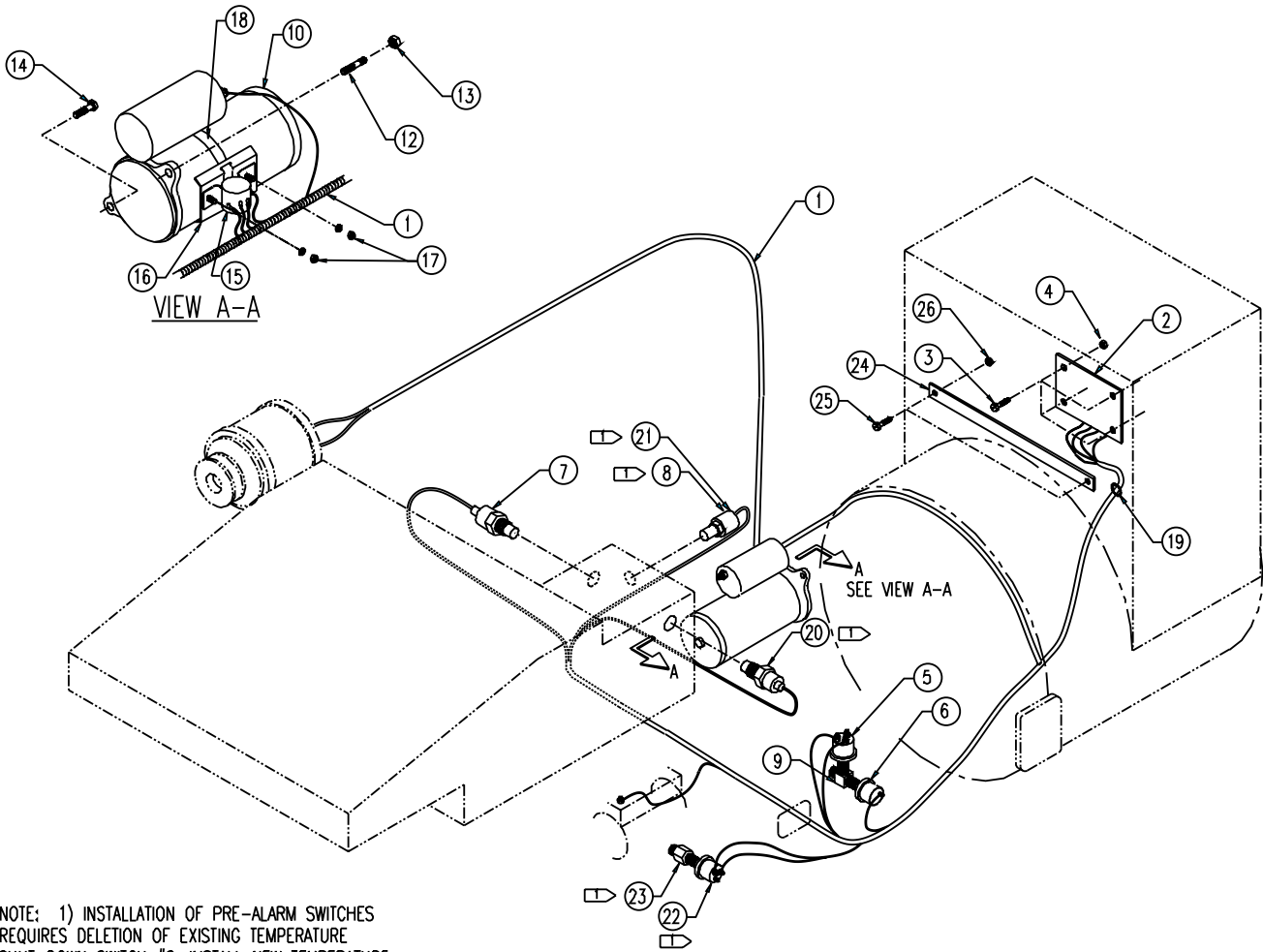

NOTE: 1) INSTALLATION OF PRE-ALARM SWITCHES
REQUIRES DELETION OF EXISTING TEMPERATURE
SHUT-DOWN SWITCH #8. INSTALL NEW TEMPERATURE
SWITCH #20, TEMPERATURE PRE-ALARM SWITCH #21
& PRESSURE PRE-ALARM SWITCH #22(+ ADAPTER #23)
AS SHOWN.

A-8524/ C-4471

Electrical System 12V Isolated Ground

M1064D - T1, M40C2, & M55C2

KEY	PART NUMBER	QTY	DESCRIPTION	Serial Number
1	22-49404	1	Engine Wire Harness (Isolated Ground)	-
2	22-70083	1	Relay Board Assembly, 12 volt (see Parts Detail)	-
	22-70086	1	Relay Board Assembly, 12 volt (Autostart units - see Parts Detail)	-
3	12-00001	4	Machine Screw, BH Slotted #10-32 x 3/4" S/S	-
4	14-00006	4	Hex Nut, Nylock #10-32	-
5	22-40915	1	Pressure Switch, 15 PSI, 1/8 NPT	-
6	22-42803	1	Pressure Sender, 0-80 PSI, (Isolated Ground 1/8 NPT, Single Station)	-
	22-74803	1	Pressure Sender, 0-80 PSI, (Isolated Ground 1/8 NPT, Dual Station)	-
7	22-42802	1	Temperature Sender 250°F, (Isolated Ground 1/2 NPT, Single Station)	-
	22-74802	1	Temperature Sender 250°F, (Isolated Ground 1/4 NPT, Dual Station)	-
8	22-40907	1	Temperature Switch 205°F (3/8 NPT, replaced by #20 when equipped with pre-alarm option)	-
9	21-05400	1	Street Tee, Steel, 1/8 NPT	-
10	22-41078	1	Starter, 12V Isolated Ground	-
12	13-05001	1	Stud, M10 x 1.5 x 25 mm	-
13	14-80811	1	Hex Nut, Flanged, M10 x 1.5	-
14	12-80832	1	Cap Screw, Hex Head, Flanged, M10 x 1.5 x 30 mm	-
15	22-41080	1	Solenoid, 12V DC 65 amp, N.O. Isolated Ground	-
16	23-40009	1	Bracket, Solenoid Mounting	-
17	14-00112	2	Hex Nut, Nylock, 1/4-20	-
18	19-00060	1	Hose Clamp #60	-
19	00-40028	1	Grommet	-
20	22-40904	1	Temperature Switch, 205°F (with Pre-alarm option)	-
21	22-40910	1	Temperature Switch, 195°F (with Pre-alarm option)	-
23	21-00023	1	Adapter 1/8 NPT (with Pre-alarm option)	-
24	22-41077	1	Terminal Strip (with Pre-alarm option)	-
25	21-00135	1	Bushing, Brass 1/2 NPT x 1/4 NPT (for #7, 22-74802)	-

Electrical System 24V Standard Ground

M1064D - T1, M40C2, & M55C2

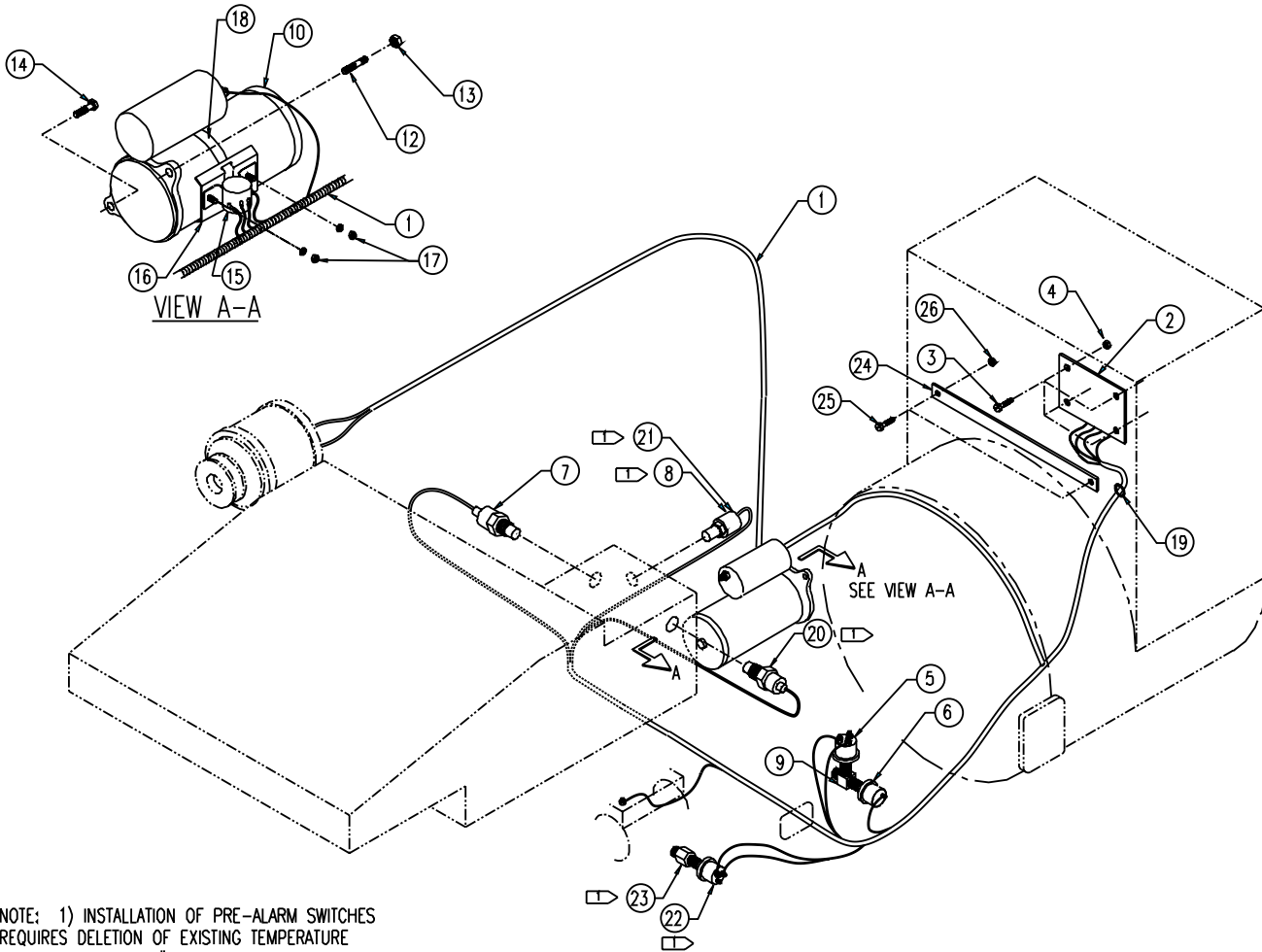

NOTE: 1) INSTALLATION OF PRE-ALARM SWITCHES
REQUIRES DELETION OF EXISTING TEMPERATURE
SHUT-DOWN SWITCH #8. INSTALL NEW TEMPERATURE
SWITCH #20, TEMPERATURE PRE-ALARM SWITCH #21
& PRESSURE PRE-ALARM SWITCH #22(+ ADAPTER #23)
AS SHOWN.

A-8525/ C-4471

Electrical System 24V Standard Ground

M1064D - T1, M40C2, & M55C2

KEY	PART NUMBER	QTY	DESCRIPTION	SERIAL NUMBER
1	22-49401	1	Engine Wire Harness, (Standard Ground)	-
2	22-70084	1	Relay Board Assembly, 24 volt (see Parts Detail)	-
	22-70087	1	Relay Board Assembly, 24 volt (Autostart units - see Parts Detail)	-
3	12-00001	4	Machine Screw, BH Slotted #10-32 x 3/4" S/S	-
4	14-00006	4	Hex Nut, Nylock #10-32	-
5	22-40915	1	Pressure Switch, 15 PSI, 1/8 NPT	-
6	22-41016	1	Pressure Sender, 0-80 PSI, (Standard Ground 1/8 NPT, Single Station)	-
	22-71016	1	Pressure Sender, 0-80 PSI, (Standard Ground 1/8 NPT, Dual Station)	-
7	22-41026	1	Temperature Sender, 250°F, (Standard Ground 1/2 NPT, Single Station)	-
	22-71026	1	Temperature Sender 250°F, (Standard Ground 1/4 NPT, Dual Station)	-
8	22-40907	1	Temperature Switch, 205°F, (3/8 NPT, replaced by #20 when equipped with pre-alarm option)	-
9	21-05400	1	Street Tee, Steel 1/8 NPT	-
10	22-41414	1	Starter, 24V Standard Ground	-
12	13-05001	1	Stud, M10 x 1.5 x 25 mm	-
13	14-80811	1	Hex Nut, Flanged, M10 x 1.5	-
14	12-80832	1	Capscrew, Hex Head Flanged M10 x 1.5 x 30 mm	-
15	22-41079	1	Solenoid, 12V DC 65 amp, N.O. Isolated Ground	-
16	23-40009	1	Bracket, Solenoid Mounting	-
17	14-00112	2	Hex Nut, Nylock, 1/4-20	-
18	19-00060	1	Hose Clamp #60	-
19	00-40028	1	Grommet	-
20	22-40904	1	Temperature Switch, 205°F (with Pre-alarm option)	-
21	22-40910	1	Temperature Switch, 195°F (with Pre-alarm option)	-
22	22-40901	1	Pressure Switch, 25 PSI (with Pre-alarm option)	-
23	21-00023	1	Adapter 1/8 NPT (with Pre-alarm option)	-
24	22-41077	1	Terminal Strip (with Pre-alarm option)	-
25	21-00135	1	Bushing, Brass 1/2 NPT x 1/4 NPT (for #7 22-71026)	-

Electrical System 24V Isolated Ground

M1064D - T1, M40C2, & M55C2

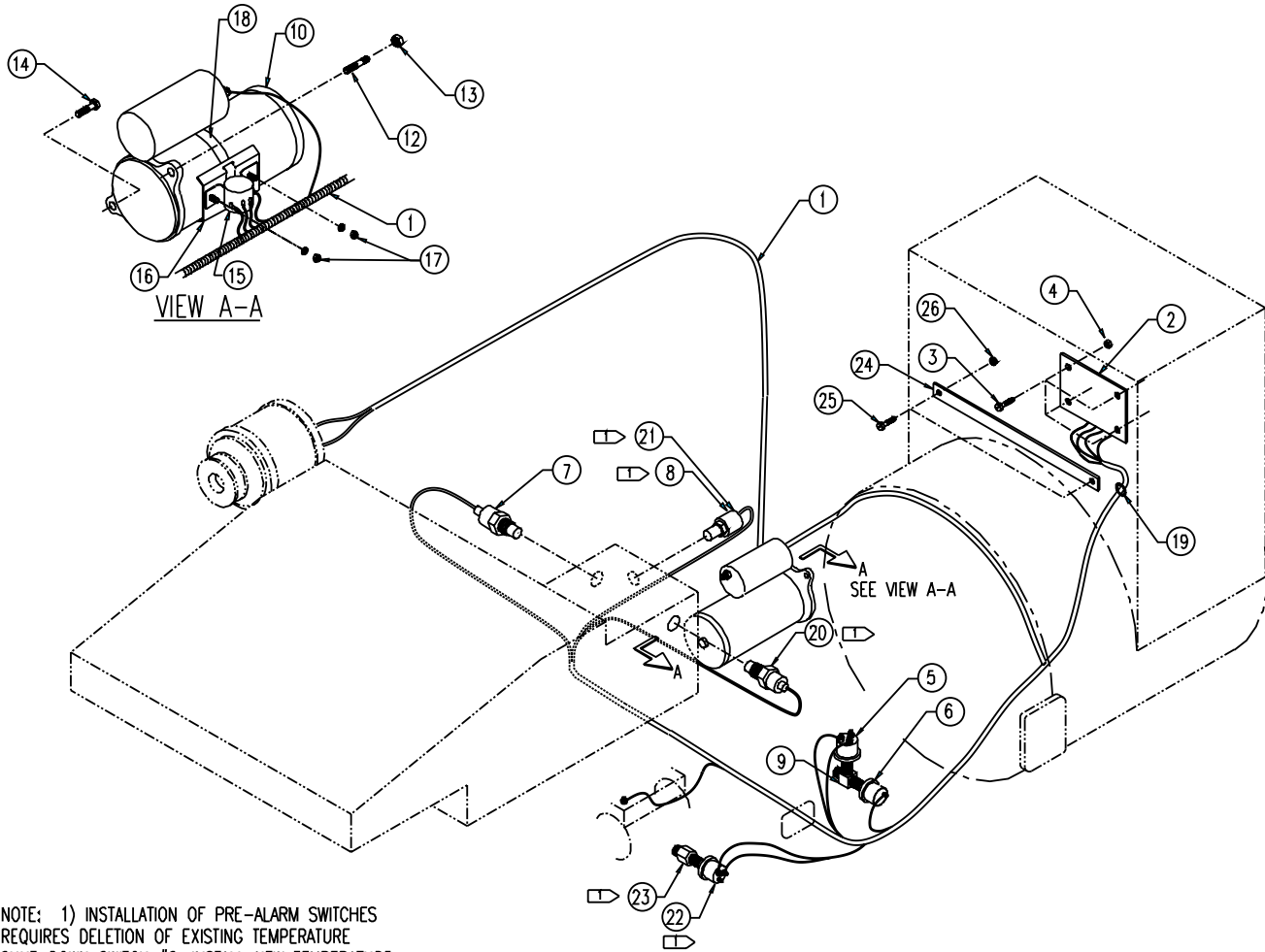

NOTE: 1) INSTALLATION OF PRE-ALARM SWITCHES
REQUIRES DELETION OF EXISTING TEMPERATURE
SHUT-DOWN SWITCH #8. INSTALL NEW TEMPERATURE
SWITCH #20, TEMPERATURE PRE-ALARM SWITCH #21
& PRESSURE PRE-ALARM SWITCH #22(+ ADAPTER #23)
AS SHOWN.

A-8524/ C-4471

Electrical System 24V Isolated Ground

M1064D - T1, M40C2, & M55C2

KEY	PART NUMBER	QTY	DESCRIPTION	SERIAL NUMBER
1	22-49404	1	Engine Wire Harness (Isolated Ground)	-
2	22-70084	1	Relay Board Assembly, 24 volt (see Parts Detail)	-
	22-70087	1	Relay Board Assembly, 24 volt (Autostart units - see Parts Detail)	-
3	12-00001	4	Machine Screw, BH Slotted #10-32 x 3/4" S/S	-
4	14-00006	4	Hex Nut, Nylock #10-32	-
5	22-40915	1	Pressure Switch, 15 PSI, 1/8 NPT	-
6	22-42803	1	Pressure Sender, 0-80 PSI (Isolated Ground 1/8 NPT, Single Station)	-
	22-74803	1	Pressure Sender, 0-80 PSI (Isolated Ground 1/8 NPT, Dual Station)	-
7	22-42802	1	Temperature Sender 250°F (Isolated Ground 1/2 NPT, Single Station)	-
	22-74802	1	Temperature Sender 250°F (Isolated Ground 1/4 NPT, Dual Station)	-
8	22-40907	1	Temperature Switch 205°F (3/8 NPT, replaced by #20 when equipped with pre-alarm option)	-
9	21-05400	1	Street Tee, Steel 1/8 NPT	-
10	22-41414	1	Starter, 24V Isolated Ground	-
12	13-05001	1	Stud, M10 x 1.5 x 25 mm	-
13	14-80811	1	Hex Nut, Flanged M10 x 1.5	-
14	12-80832	1	Capscrew, Hex Head Flanged, M10 x 1.5 x 30 mm	-
15	22-41079	1	Solenoid, 24V DC 65 amp N.O. Isolated Ground	-
16	23-40009	1	Bracket, Solenoid Mounting	-
17	14-00112	2	Hex Nut, Nylock, 1/4-20	-
18	19-00060	1	Hose Clamp #60	-
19	00-40028	1	Grommet	-
20	22-40904	1	Temperature Switch 205°F (with Pre-alarm option)	-
21	22-40910	1	Temperature Switch 195°F (with Pre-alarm option)	-
22	22-40901	1	Oil Pressure Switch, 25 PSI 1/8 NPT	-
23	21-05400	1	Street Tee, Steel 1/8 NPT	-
24	22-41077	1	Terminal Strip, 10 Connection 600 VA	-
25	21-00005	2	Machine Screw, BH Slotted #8-32 x 3/4"	-
26	14-00003	2	Hex Nut Nylock #8-32	-
27	21-00135	1	Bushing, Brass 1/2 NPT x 1/4 NPT (for #7, 22-74802, not shown)	-

Electrical System 12V Standard Ground

M1064T2 - A, M65C2

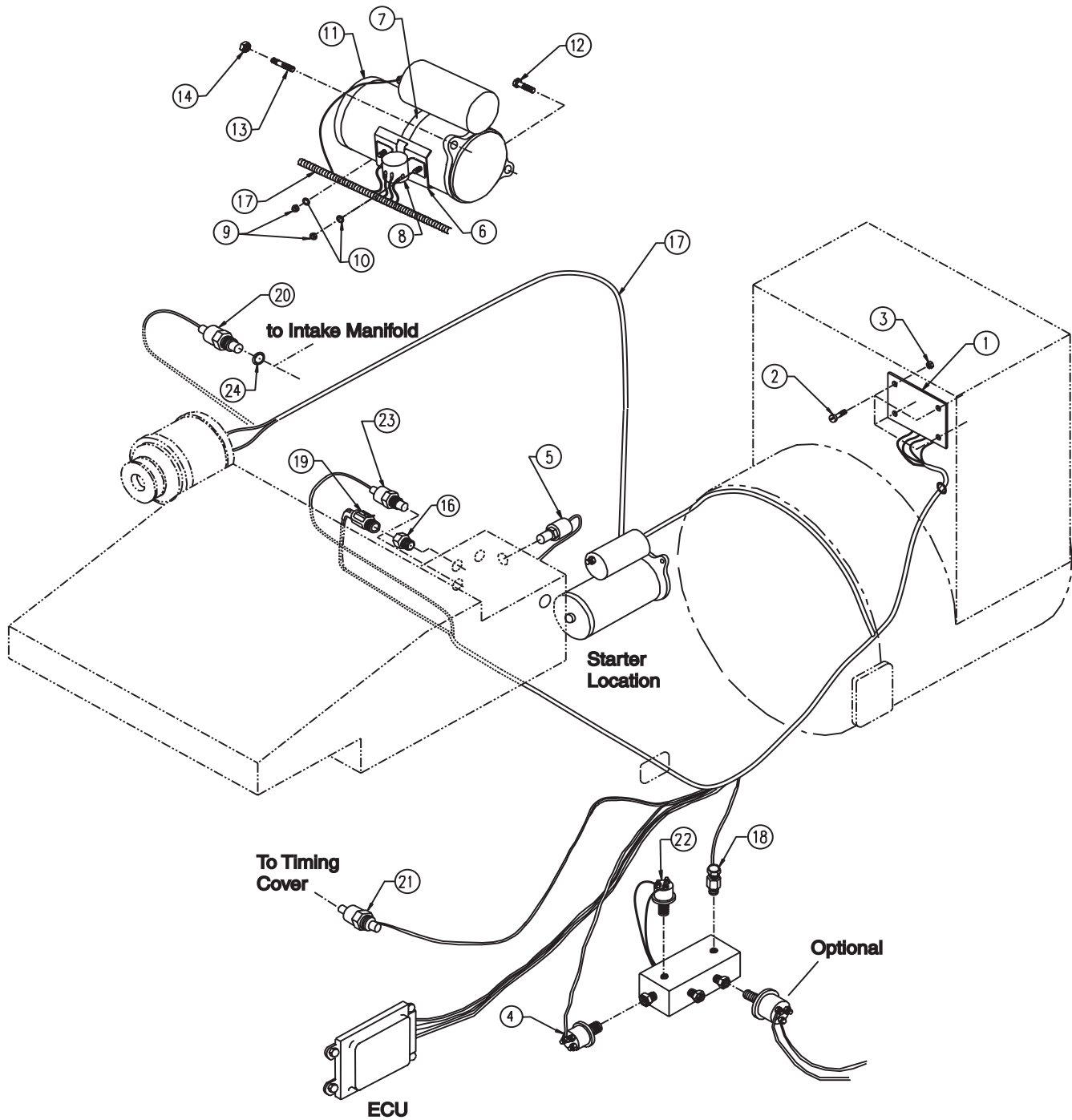

A-10482/ C-4471z

Electrical System 12V Standard Ground

M1064T2 - A, M65C2

KEY	PART NUMBER	QTY	DESCRIPTION	SERIAL NUMBER
1	22-70083	1	Relay Board Assembly (see Parts Detail)	-
	22-70086	1	Relay Board Assembly 12 Volt Autostart (see Parts Detail)	-
2	12-00001	4	Machine Screw, BH Slotted #10- 32 x 3/4" S/S	-
3	14-00006	4	Hex Nut, Nylock #10-32	-
4	22-40915	1	Pressure Switch, 15 PSI 1/8 NPT	-
5	22-40907	1	Temperature Switch, 205°F	-
6	22-40009	1	Bracket, Solenoid Mounting	-
7	19-00060	1	Hose Clamp #60	-
8	22-41080	1	Solenoid, 12 VDC 65 Amp	-
9	14-00112	2	Hex Nut, Nylock 1/4- 20	-
10	15-00121	2	Flat Washer 1/4" SAE	-
11	RE68470	1	Starter 12V Standard Ground	-
12	12-80832	1	Capscrew, Hex Head Flanged M10 x 1.5 x 30 mm	-
13	13-05001	1	Stud M10 x 1.5 x 25 mm (37mm LOA)	-
14	14-80811	1	Hex Nut, Flanged M10 x 1.5	-
15	AT157679	1	Transient Voltage Protector 12 Volt (not shown)	-
16	21-09601	1	Bushing, Steel 1/2 NPT x M14 x 1.5	-
17	22-49511	1	Wire Harness, Engine Can-Bus & DE10 Controller	-
	22-49518	**	Harness, Control System Power Supply	-
18	R167207	1	Oil Pressure Sensor (for ECU)	-
19	RE52722	1	Coolant Temperature Sensor (for ECU)	-
20	RE61812	1	Air Inlet Temperature Sensor (for ECU)	-
21	RE519144	1	Speed Sensor (for ECU)	-
22	22-41016	1	Pressure Sender 0-80 PSI Standard Ground 1/8 NPT Single Station	-
23	22-41026	1	Temperature Sender 0-250°F Standard Ground 1/2 NPT Single Station	-
24	16-00005	1	O-ring	-
			**As required (not used on units with Energise-to-stop and redundant power supply)	

Electrical System 12V Isolated Ground

M1064T2 - A, M65C2

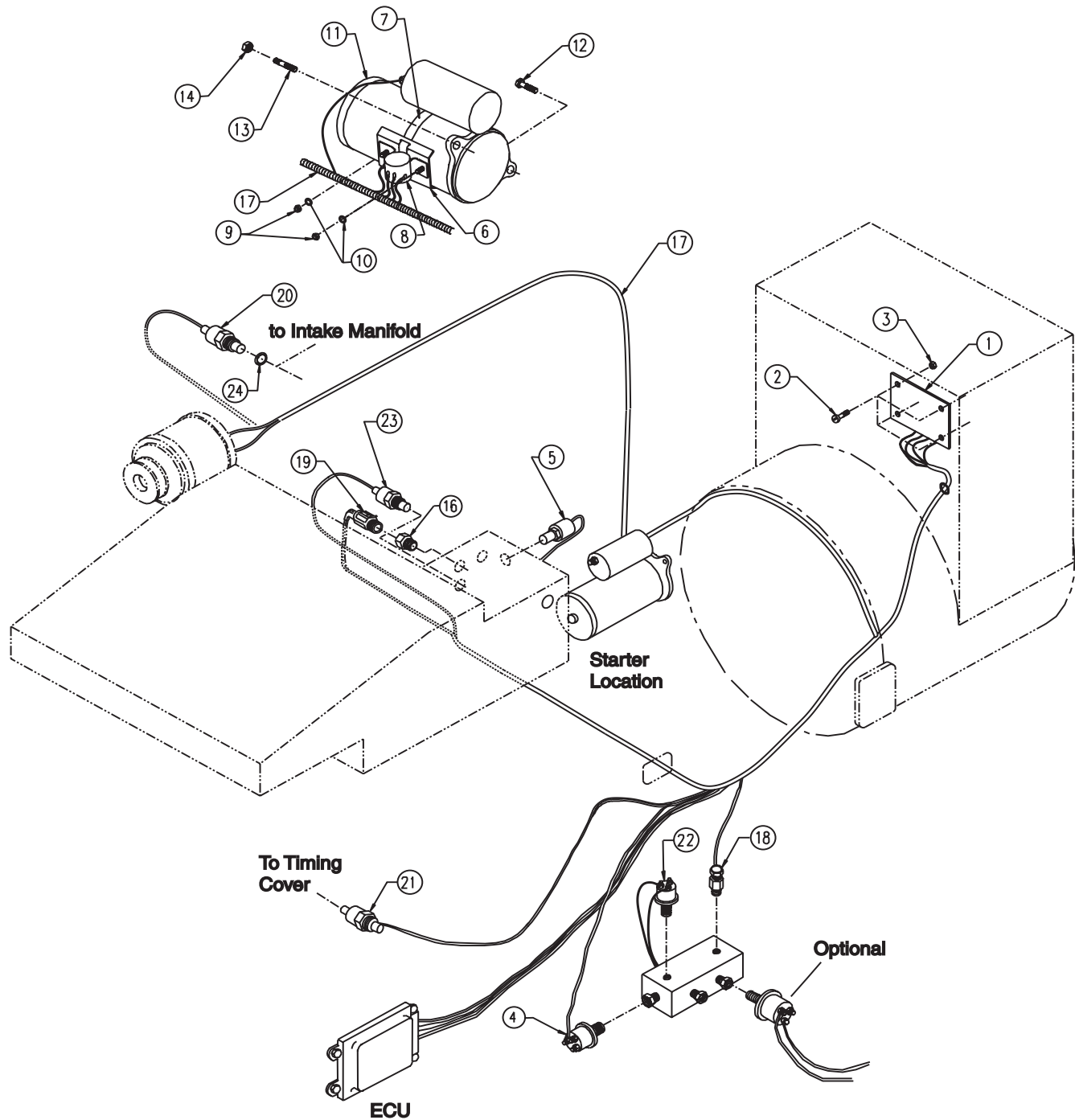

A-10483/ C-4471

Electrical System 12V Isolated Ground

M1064T2 - A, M65C2

KEY	PART NUMBER	QTY	DESCRIPTION	SERIAL NUMBER
1	22-42047	3	Relay, SPDT 12 VDC 50 Amp	-
	22-70083	1	Relay Board Assembly, Dual Station (see Parts detail)	-
	22-70086	1	Relay Board Assembly 12 V Autostart Units (see Parts detail)	-
2	12-00001	4	Machine Screw, BH Slotted #10- 32 x 3/4" S/S	-
3	14-00006	4	Hex Nut, Nylock #10-32	-
4	22-40915	1	Pressure Switch, 15 PSI 1/8 NPT	-
5	22-40907	1	Temperature Switch, 205°F	-
6	22-40009	1	Bracket, Solenoid Mounting	-
7	19-00060	1	Hose Clamp #60	-
8	22-41080	1	Solenoid, 12 VDC 65 Amp	-
9	14-00112	2	Hex Nut, Nylock 1/4- 20	-
10	15-00121	2	Flat Washer 1/4" SAE	-
11	22-41078	1	Starter 12V Isolated Ground	-
12	12-80832	1	Capscrew, Hex Head Flanged M10 x 1.5 x 30 mm	-
13	13-05001	1	Stud M10 x 1.5 x 25 mm (37mm LOA)	-
14	14-80811	1	Hex Nut, Flanged M10 x 1.5	-
15	AT157679	1	Transient Voltage Protector 12 Volt*	-
16	21-09601	1	Bushing, Steel 1/2 NPT x M14 x 1.5	-
17	22-49511	1	Wire Harness, Engine Can-Bus & DE10 Controller	-
	22-49518	**	Harness, Control System Power Supply	-
18	R167207	1	Oil Pressure Sensor (for ECU)	-
19	RE52722	1	Coolant Temperature Sensor (for ECU)	-
20	RE61812	1	Air Inlet Temperature Sensor (for ECU)	-
21	RE519144	1	Speed Sensor (for ECU)	-
22	22-42803	1	Pressure Sender 0-80 PSI Isolated Ground 1/8 NPT Single Station	-
23	22-42802	1	Temperature Sender 0-250°F Isolated Ground 1/2 NPT Single Station	-
24	16-00005	1	O-ring	-
			*Not shown	
			**As required (not used on units with Energise-to-stop and redundant power supply)	

Electrical System 24V Standard Ground

M1064T2 - A, M65C2

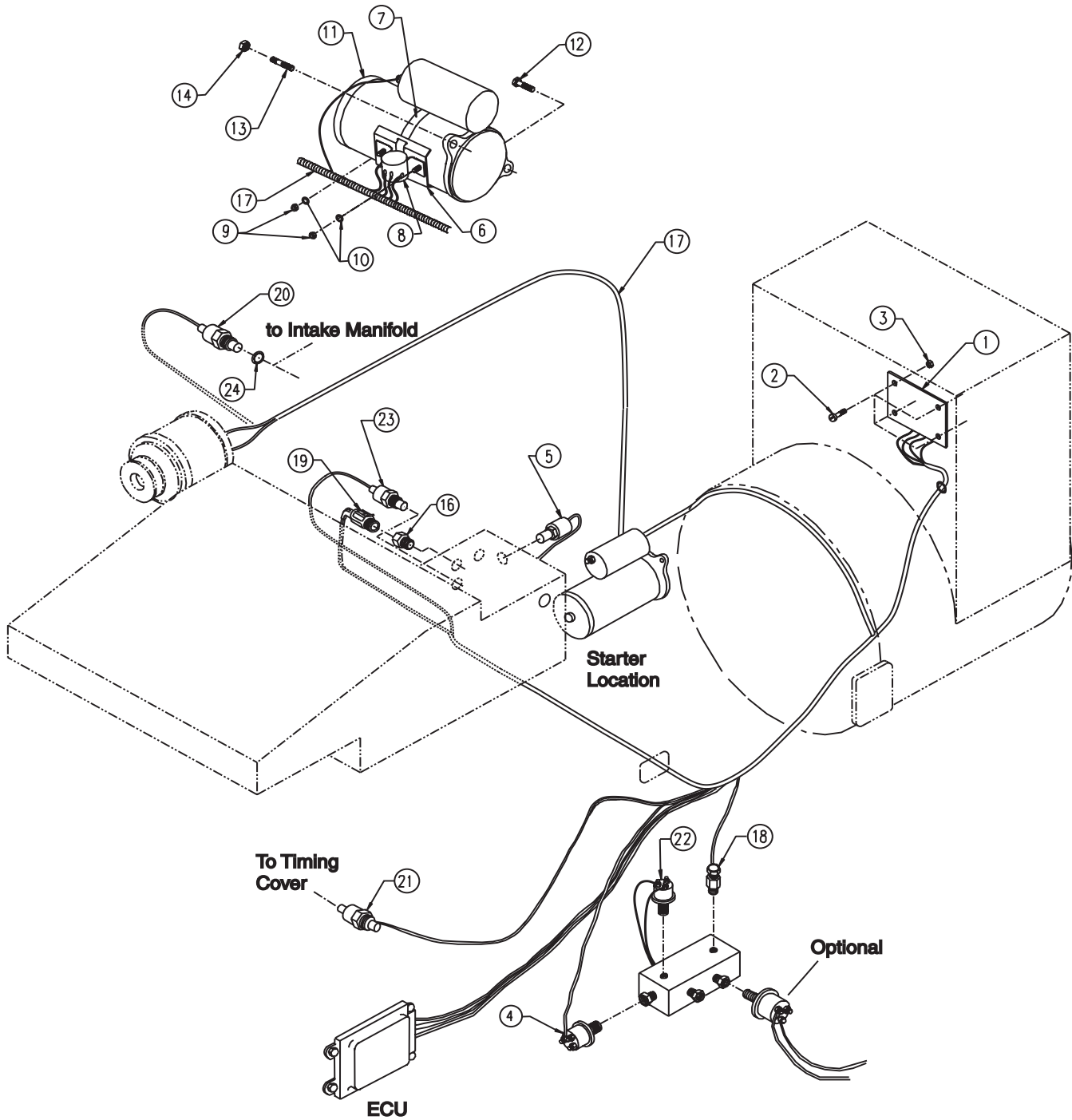

A-10484/ C-4471

Electrical System 24V Standard Ground

M1064T2 - A, M65C2

KEY	PART NUMBER	QTY	DESCRIPTION	SERIAL NUMBER
1	22-70084	1	Relay Board Assembly, Dual Station (see Parts detail)	-
	22-70087	1	Relay Board Assembly 24 Volt Autostart (see Parts detail)	-
2	12-00001	4	Machine Screw, BH Slotted #10- 32 x 3/4" S/S	-
3	14-00006	4	Hex Nut, Nylock #10-32	-
4	22-40915	1	Pressure Switch, 15 PSI 1/8 NPT	-
5	22-40907	1	Temperature Switch, 205°F	-
6	22-40009	1	Bracket, Solenoid Mounting	-
7	19-00060	1	Hose Clamp #60	-
8	22-41079	1	Solenoid, 12 VDC 65 Amp	-
9	14-00112	2	Hex Nut, Nylock 1/4- 20	-
10	15-00121	2	Flat Washer 1/4" SAE	-
11	22-41414	1	Starter 24V Isolated Ground	-
12	12-80832	1	Capscrew, Hex Head Flanged M10 x 1.5 x 30 mm	-
13	13-05001	1	Stud M10 x 1.5 x 25 mm (37mm LOA)	-
14	14-80811	1	Hex Nut, Flanged M10 x 1.5	-
15	AT163022	1	Transient Voltage Protector 24 Volt (not shown)	-
16	21-09601	1	Bushing, Steel 1/2 NPT x M14 x 1.5	-
17	22-49511	1	Wire Harness, Engine Can-Bus & DE10 Controller	-
	22-49518	**	Harness, Control System Power Supply	-
18	R167207	1	Oil Pressure Sensor (for ECU)	-
19	RE52722	1	Coolant Temperature Sensor (for ECU)	-
20	RE61812	1	Air Inlet Temperature Sensor (for ECU)	-
21	RE519144	1	Speed Sensor (for ECU)	-
22	22-41016	1	Pressure Sender 0-80 PSI Standard Ground Single Station	-
23	22-41026	1	Temperature Sender 250°F Standard Ground Single Station	-
24	16-00005	1	O-ring	-
			**As required (not used on units with Energise-to-stop and redundant power supply)	

Electrical System 24V Isolated Ground

M1064T2 - A, M65C2

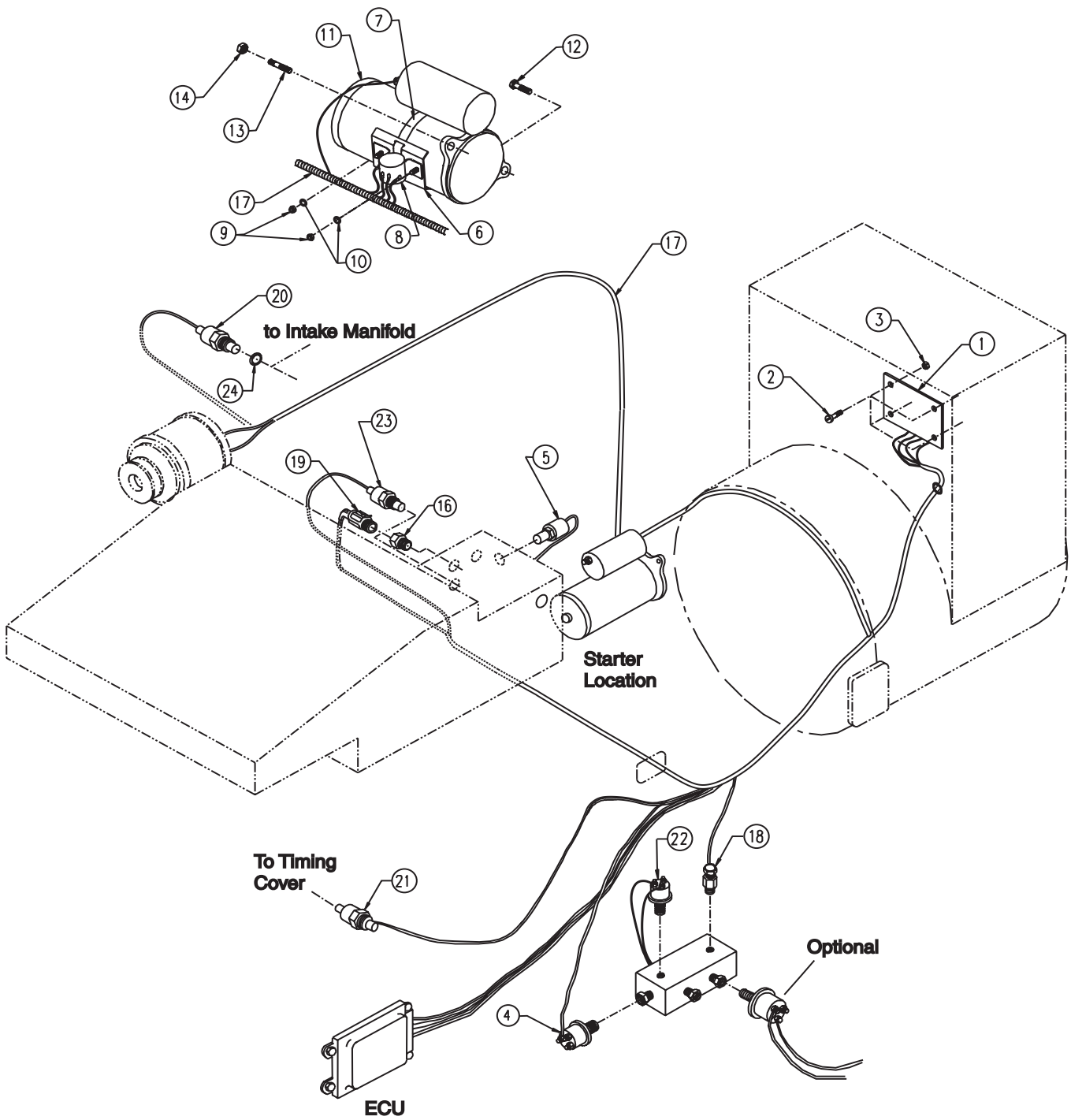

A-10485/ C-4471

Electrical System 24V Isolated Ground

M1064T2 - A, M65C2

KEY	PART NUMBER	QTY	DESCRIPTION	SERIAL NUMBER
1	22-70084	1	Relay Board Assembly, Dual Station (see Parts detail)	-
	22-70087	1	Relay Board Assembly 12 V Autostart Units (see Parts detail)	-
2	12-00001	4	Machine Screw, BH Slotted #10- 32 x 3/4" S/S	-
3	14-00006	4	Hex Nut, Nylock #10-32	-
4	22-40915	1	Pressure Switch, 15 PSI 1/8 NPT	-
5	22-40907	1	Temperature Switch, 205°F	-
6	22-40009	1	Bracket, Solenoid Mounting	-
7	19-00060	1	Hose Clamp #60	-
8	22-41079	1	Solenoid, 24 VDC 65 Amp	-
9	14-00112	2	Hex Nut, Nylock 1/4- 20	-
10	15-00121	2	Flat Washer 1/4" SAE	-
11	22-41414	1	Starter 24V Isolated Ground	-
12	12-80832	1	Capscrew, Hex Head Flanged M10 x 1.5 x 30 mm	-
13	13-05001	1	Stud M10 x 1.5 x 25 mm (37mm LOA)	-
14	14-80811	1	Hex Nut, Flanged M10 x 1.5	-
15	AT163022	1	Transient Voltage Protector 24 Volt	-
16	21-09601	1	Bushing, Steel 1/2 NPT x M14 x 1.5	-
17	22-49511	1	Wire Harness, Engine Can-Bus & DE10 Controller	-
	22-49518	**	Harness, Control System Power Supply	-
18	R167207	1	Oil Pressure Sensor (for ECU)	-
19	RE52722	1	Coolant Temperature Sensor (for ECU)	-
20	RE61812	1	Air Inlet Temperature Sensor (for ECU)	-
21	RE519144	1	Speed Sensor (for ECU)	-
22	22-42803	1	Pressure Sender 0-80 PSI Isolated Ground 1/8 NPT Single Station	-
23	22-42802	1	Temperature Sender 0-250°F Isolated Ground 1/2 NPT Single Station	-
24	16-00005	1	O-ring	-
			**As required (not used on units with Energise-to-stop and redundant power supply)	

Electrical System 12V Standard Ground

M1064H

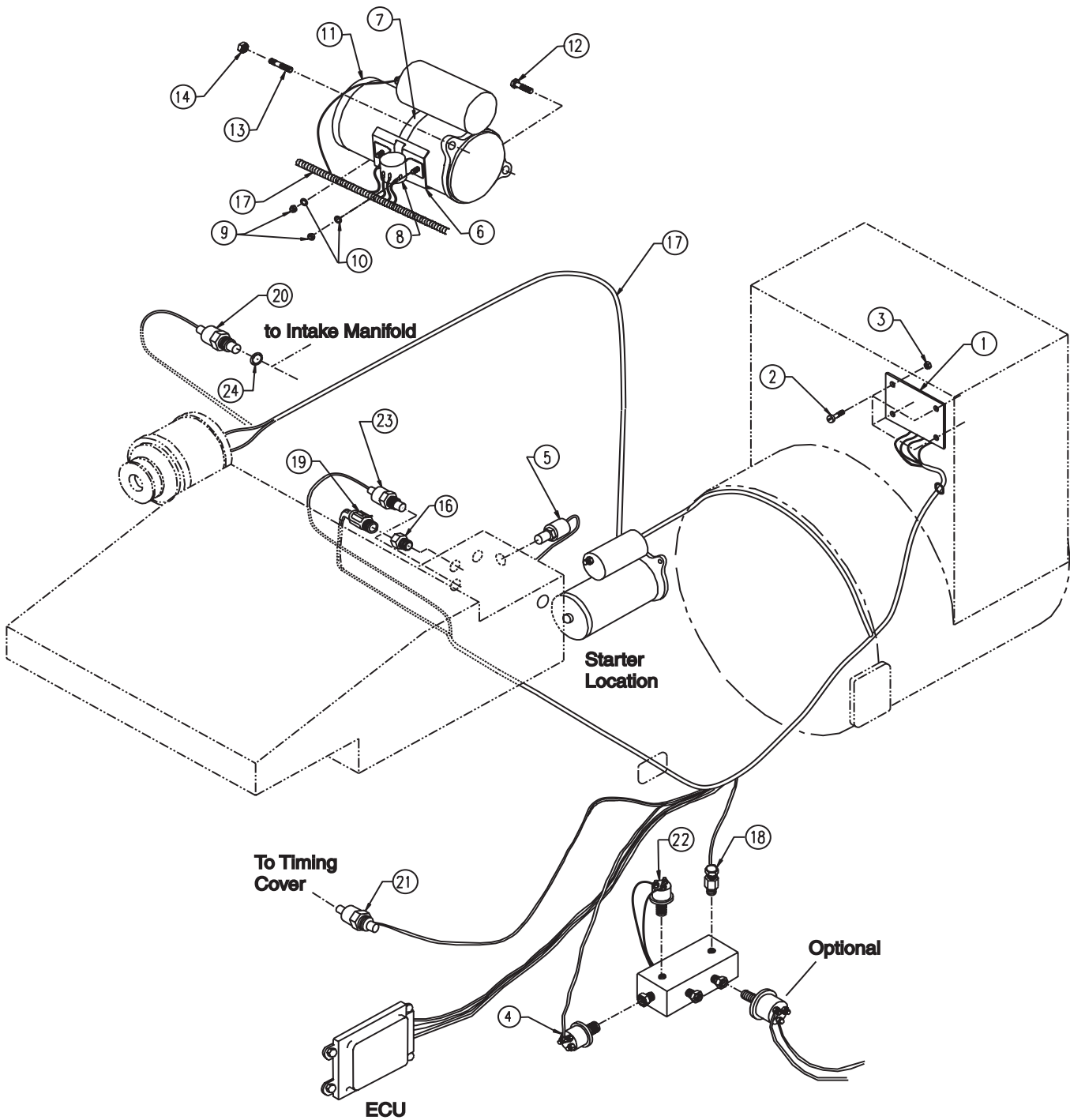

A-/ C-4471

Electrical System 12V Standard Ground

M1064H

KEY	PART NUMBER	QTY	DESCRIPTION	SERIAL NUMBER
1	22-70083	1	Relay Board Assembly (see Parts Detail)	-
	22-70086	1	Relay Board Assembly 12 Volt Autostart (see Parts Detail)	-
2	12-00001	4	Machine Screw, BH Slotted #10- 32 x 3/4" S/S	-
3	14-00006	4	Hex Nut, Nylock #10-32	-
4	22-40915	1	Pressure Switch, 15 PSI 1/8 NPT	-
5	22-40907	1	Temperature Switch, 205°F	-
6	22-40009	1	Bracket, Solenoid Mounting	-
7	19-00060	1	Hose Clamp #60	-
8	22-41080	1	Solenoid, 12 VDC 65 Amp	-
9	14-00112	2	Hex Nut, Nylock 1/4- 20	-
10	15-00121	2	Flat Washer 1/4" SAE	-
11	RE68470	1	Starter 12V Standard Ground	-
12	12-80832	1	Capscrew, Hex Head Flanged M10 x 1.5 x 30 mm	-
13	13-05001	1	Stud M10 x 1.5 x 25 mm (37mm LOA)	-
14	14-80811	1	Hex Nut, Flanged M10 x 1.5	-
15	AT157679	1	Transient Voltage Protector 12 Volt (not shown)	-
16	21-09601	1	Bushing, Steel 1/2 NPT x M14 x 1.5	-
17	22-49509	1	Wire Harness, Engine Can-Bus & HPCR Controller	-
	22-49518	**	Harness, Control System Power Supply	-
18	R167207	1	Oil Pressure Sensor (for ECU)	-
19	RE52722	1	Coolant Temperature Sensor (for ECU)	-
20	RE61812	1	Air Inlet Temperature Sensor (for ECU)	-
21	RE519144	1	Speed Sensor (for ECU)	-
22	22-41016	1	Pressure Sender 0-80 PSI Standard Ground 1/8 NPT Single Station	-
23	22-41026	1	Temperature Sender 0-250°F Standard Ground 1/2 NPT Single Station	-
24	16-00005	1	O-ring	-
25	RE516336	1	Sensor, Fuel Temperature (not shown)	-
26	R50919	1	O-ring (not shown)	-
			**As required (not used on units with Energise-to-stop and redundant power supply)	

Electrical System 12V Isolated Ground

M1064H

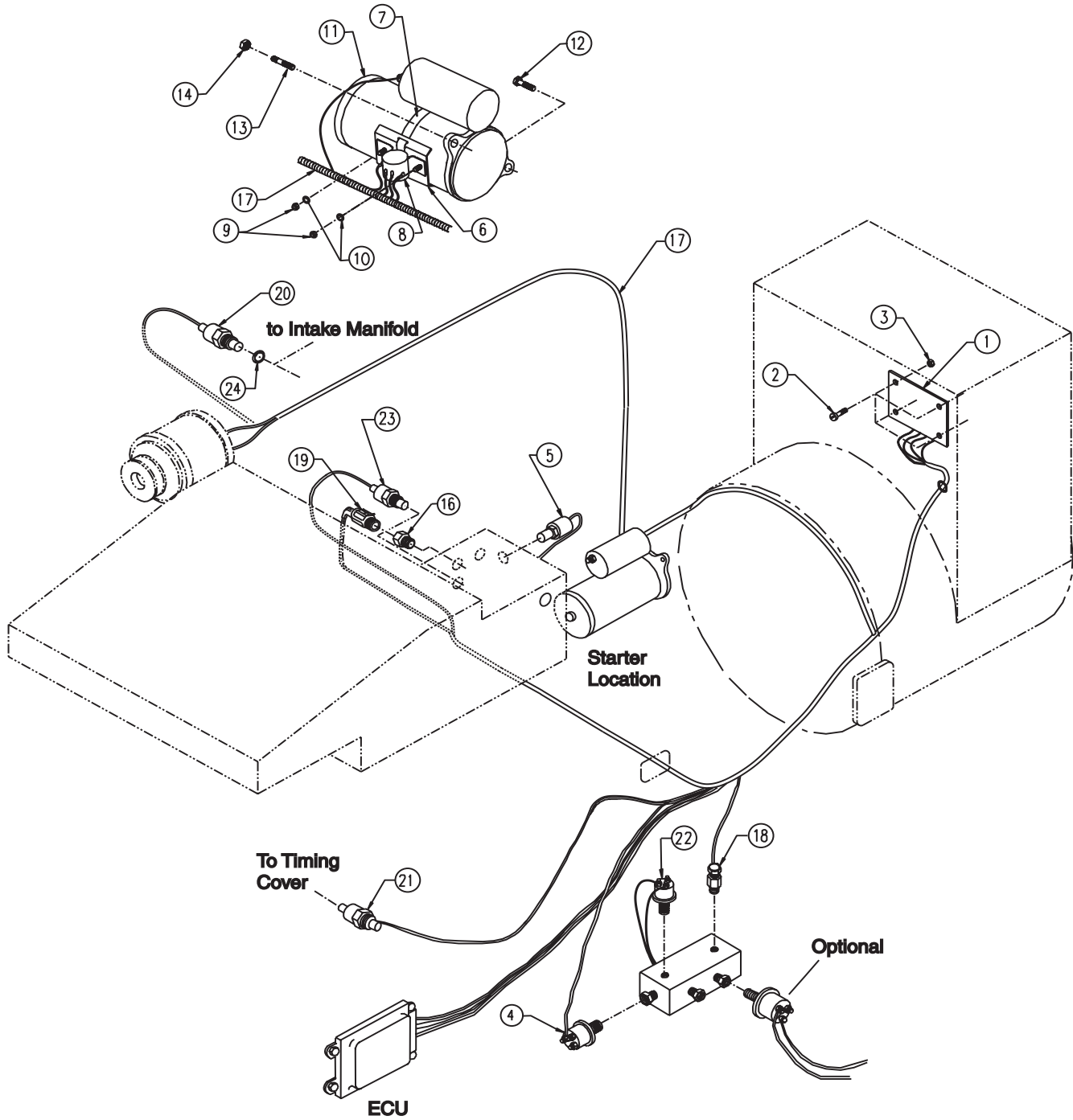

A-/ C-4471

Electrical System 12V Isolated Ground

M1064H

KEY	PART NUMBER	QTY	DESCRIPTION	SERIAL NUMBER
1	22-42047	3	Relay, SPDT 12 VDC 50 Amp	
	22-70083	1	Relay Board Assembly, Dual Station (see Parts detail)	-
	22-70086	1	Relay Board Assembly 12 V Autostart Units (see Parts detail)	-
2	12-00001	4	Machine Screw, BH Slotted #10- 32 x 3/4" S/S	-
3	14-00006	4	Hex Nut, Nylock #10-32	-
4	22-40915	1	Pressure Switch, 15 PSI 1/8 NPT	-
5	22-40907	1	Temperature Switch, 205°F	-
6	22-40009	1	Bracket, Solenoid Mounting	-
7	19-00060	1	Hose Clamp #60	-
8	22-41080	1	Solenoid, 12 VDC 65 Amp	-
9	14-00112	2	Hex Nut, Nylock 1/4- 20	-
10	15-00121	2	Flat Washer 1/4" SAE	-
11	22-41078	1	Starter 12V Isolated Ground	-
12	12-80832	1	Capscrew, Hex Head Flanged M10 x 1.5 x 30 mm	-
13	13-05001	1	Stud M10 x 1.5 x 25 mm (37mm LOA)	-
14	14-80811	1	Hex Nut, Flanged M10 x 1.5	-
15	AT157679	1	Transient Voltage Protector 12 Volt*	-
16	21-09601	1	Bushing, Steel 1/2 NPT x M14 x 1.5	-
17	22-49509	1	Wire Harness, Engine Can-Bus & HPCR Controller	-
	22-49518	**	Harness, Control System Power Supply	-
18	R167207	1	Oil Pressure Sensor (for ECU)	-
19	RE52722	1	Coolant Temperature Sensor (for ECU)	-
20	RE61812	1	Air Inlet Temperature Sensor (for ECU)	-
21	RE519144	1	Speed Sensor (for ECU)	-
22	22-42803	1	Pressure Sender 0-80 PSI Isolated Ground 1/8 NPT Single Station	-
23	22-42802	1	Temperature Sender 0-250°F Isolated Ground 1/2 NPT Single Station	-
24	16-00005	1	O-ring	-
25	RE516336	1	Sensor, Fuel Temperature*	-
26	R50919	1	O-ring*	-
			*Not shown	
			**As required, (not used on units with Energise-to-stop and redundant power supply)	

Electrical System 24V Standard Ground

M1064H

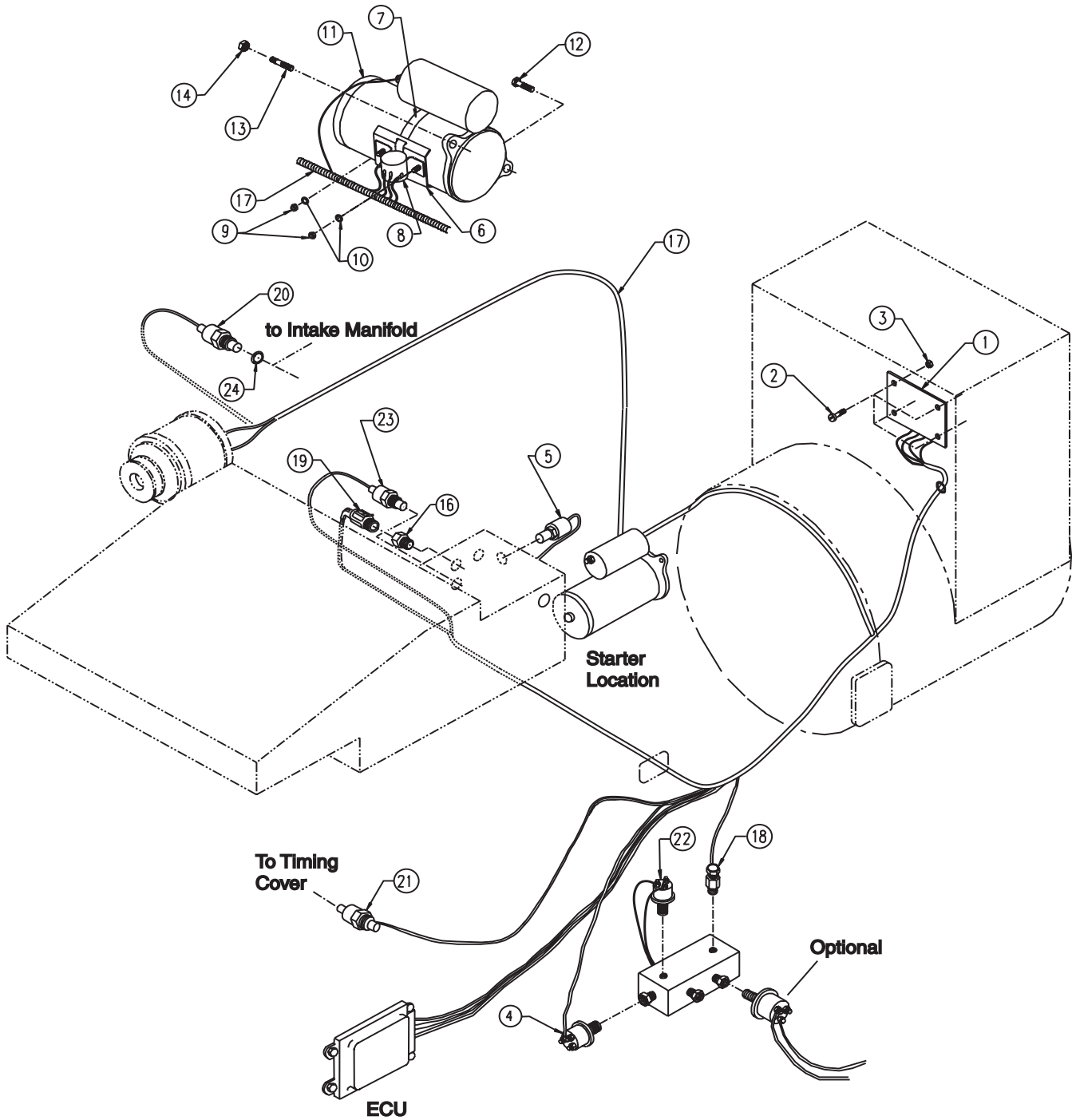

A-/ C-4471

Electrical System 24V Standard Ground

M1064H

KEY	PART NUMBER	QTY	DESCRIPTION	SERIAL NUMBER
1	22-70084	1	Relay Board Assembly, Dual Station (see Parts detail)	-
	22-70087	1	Relay Board Assembly 24 Volt Autostart (see Parts detail)	-
2	12-00001	4	Machine Screw, BH Slotted #10- 32 x 3/4" S/S	-
3	14-00006	4	Hex Nut, Nylock #10-32	-
4	22-40915	1	Pressure Switch, 15 PSI 1/8 NPT	-
5	22-40907	1	Temperature Switch, 205°F	-
6	22-40009	1	Bracket, Solenoid Mounting	-
7	19-00060	1	Hose Clamp #60	-
8	22-41079	1	Solenoid, 12 VDC 65 Amp	-
9	14-00112	2	Hex Nut, Nylock 1/4- 20	-
10	15-00121	2	Flat Washer 1/4" SAE	-
11	22-41414	1	Starter 24V Isolated Ground	-
12	12-80832	1	Capscrew, Hex Head Flanged M10 x 1.5 x 30 mm	-
13	13-05001	1	Stud M10 x 1.5 x 25 mm (37mm LOA)	-
14	14-80811	1	Hex Nut, Flanged M10 x 1.5	-
15	AT163022	1	Transient Voltage Protector 24 Volt (not shown)	-
16	21-09601	1	Bushing, Steel 1/2 NPT x M14 x 1.5	-
17	22-49509	1	Wire Harness, Engine Can-Bus & HPCR Controller	-
	22-49518	**	Harness, Control System Power Supply	-
18	R167207	1	Oil Pressure Sensor (for ECU)	-
19	RE52722	1	Coolant Temperature Sensor (for ECU)	-
20	RE61812	1	Air Inlet Temperature Sensor (for ECU)	-
21	RE519144	1	Speed Sensor (for ECU)	-
22	22-41016	1	Pressure Sender 0-80 PSI Standard Ground Single Station	-
23	22-41026	1	Temperature Sender 250°F Standard Ground Single Station	-
24	16-00005	1	O-ring	-
25	RE516336	1	Sensor, Fuel Temperature (not shown)	-
26	R50919	1	O-ring (not shown)	-
			**As required, (not used on units with Energise-to-stop and redundant power supply)	

Electrical System 24V Isolated Ground

M1064H

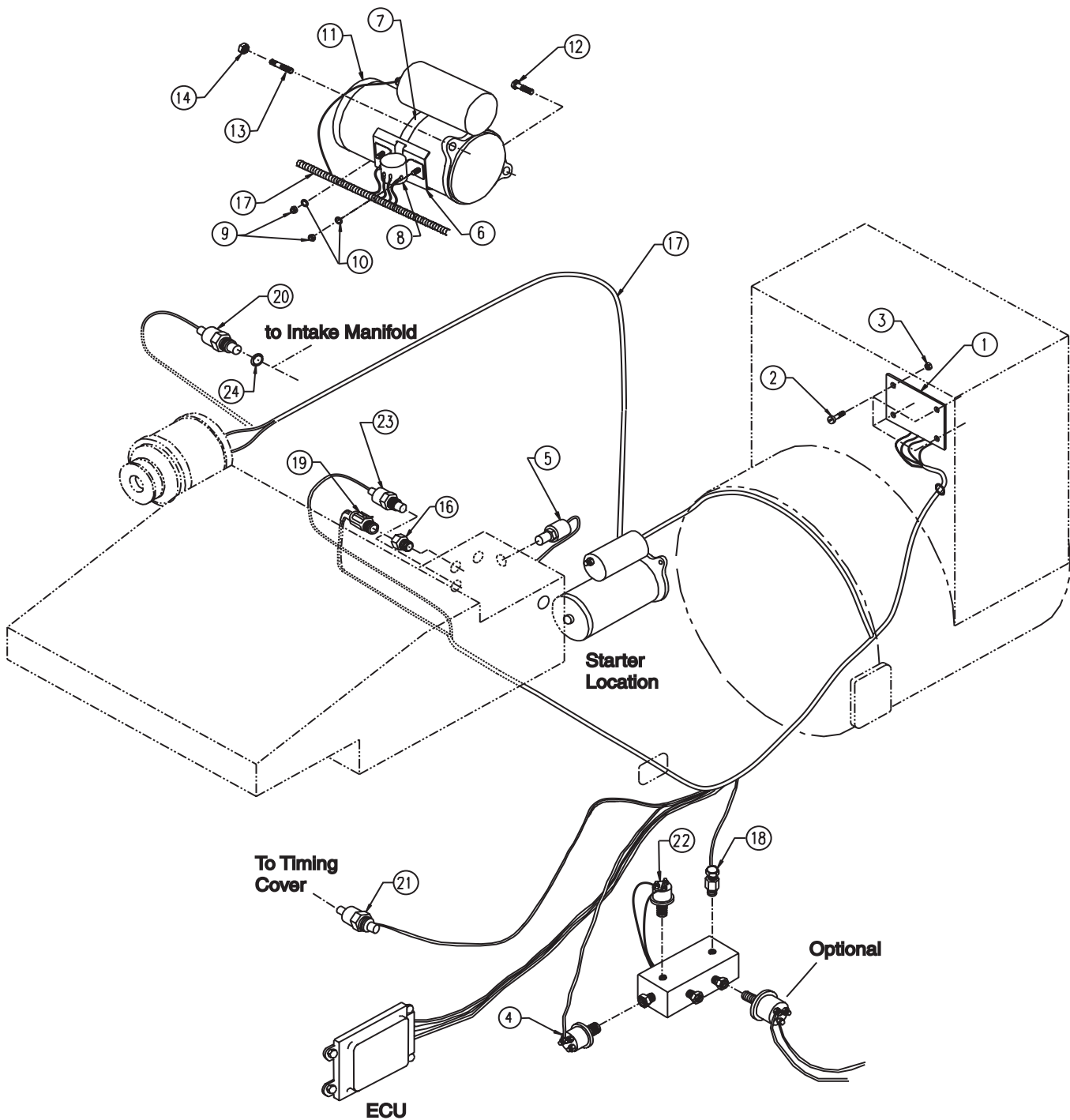

A-/ C-4471

Electrical System 24V Isolated Ground

M1064H

KEY	PART NUMBER	QTY	DESCRIPTION	SERIAL NUMBER
1	22-70084	1	Relay Board Assembly, Dual Station (see Parts detail)	-
	22-70087	1	Relay Board Assembly 12 V Autostart Units (see Parts detail)	-
2	12-00001	4	Machine Screw, BH Slotted #10- 32 x 3/4" S/S	-
3	14-00006	4	Hex Nut, Nylock #10-32	-
4	22-40915	1	Pressure Switch, 15 PSI 1/8 NPT	-
5	22-40907	1	Temperature Switch, 205°F	-
6	22-40009	1	Bracket, Solenoid Mounting	-
7	19-00060	1	Hose Clamp #60	-
8	22-41079	1	Solenoid, 24 VDC 65 Amp	-
9	14-00112	2	Hex Nut, Nylock 1/4- 20	-
10	15-00121	2	Flat Washer 1/4" SAE	-
11	22-41414	1	Starter 24V Isolated Ground	-
12	12-80832	1	Capscrew, Hex Head Flanged M10 x 1.5 x 30 mm	-
13	13-05001	1	Stud M10 x 1.5 x 25 mm (37mm LOA)	-
14	14-80811	1	Hex Nut, Flanged M10 x 1.5	-
15	AT163022	1	Transient Voltage Protector 24 Volt	-
16	21-09601	1	Bushing, Steel 1/2 NPT x M14 x 1.5	-
17	22-49509	1	Wire Harness, Engine Can-Bus & HPCR Controller	-
	22-49518	**	Harness, Control System Power Supply	-
18	RE167207	1	Oil Pressure Sensor (for ECU)	-
19	RE52722	1	Coolant Temperature Sensor (for ECU)	-
20	RE61812	1	Air Inlet Temperature Sensor (for ECU)	-
21	RE519144	1	Speed Sensor (for ECU)	-
22	22-42803	1	Pressure Sender 0-80 PSI Isolated Ground 1/8 NPT Single Station	-
23	22-42802	1	Temperature Sender 0-250°F Isolated Ground 1/2 NPT Single Station	-
24	16-00005	1	O-ring	-
25	RE516336	1	Sensor, Fuel Temperature (not shown)	-
26	R50919	1	O-ring (not shown)	-
			**As required (not used on units with Energise-to-stop and redundant power supply)	

Oil Pressure Manifold

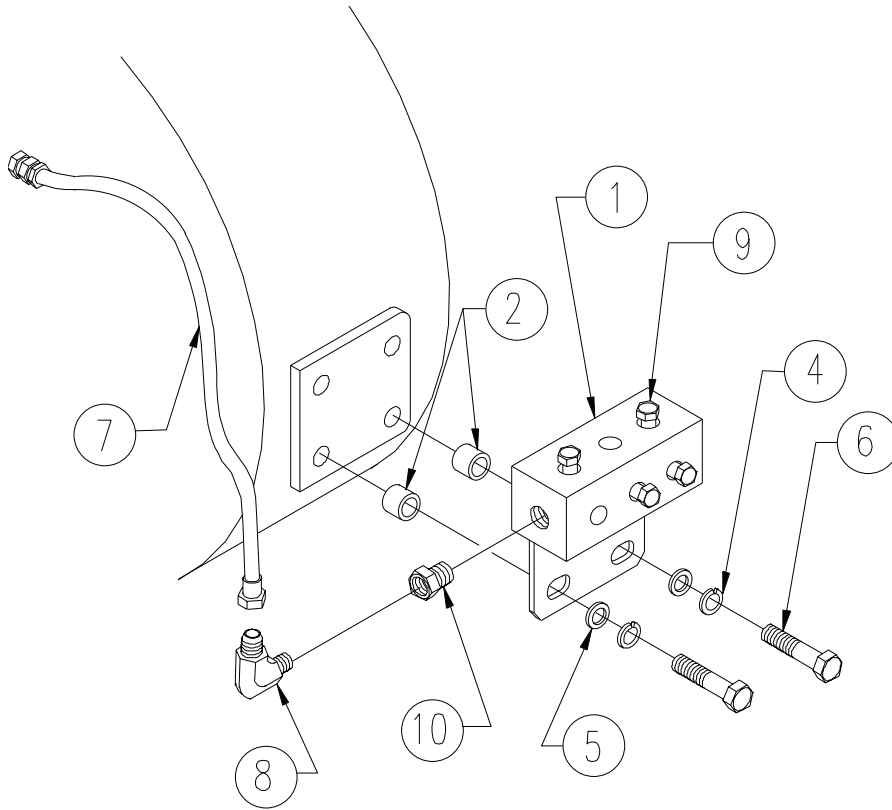

A-10578A/ B-8704

KEY	PART NUMBER	QTY	DESCRIPTION	SERIAL NUMBER
1	10-85401	1	Oil Pressure Manifold	-
2	21-75703	2	Spacer	-
4	15-00912	2	Lock Washer, Helical M12	-
5	15-00007	2	Flat Washer, M12	-
6	21-52205	1	Male Connector, Steel 1/8 NPT x 1/4- 37T	-
7	18-55405	1	Hose Assembly 1/4" I.D. x 9"	-
8	21-71053	1	Male Elbow 90° Steel 1/8 NPT x 1/4- 37T	-
9	21-00012	4	Plug, Hex Head Brass 1/8 NPT	-
10	21-00132	1	Bushing, Brass 1/4 NPT x 1/8 NPT	-

Stop Solenoid 12 & 24 Volt (Injection Pump Mounted)

Stanadyne

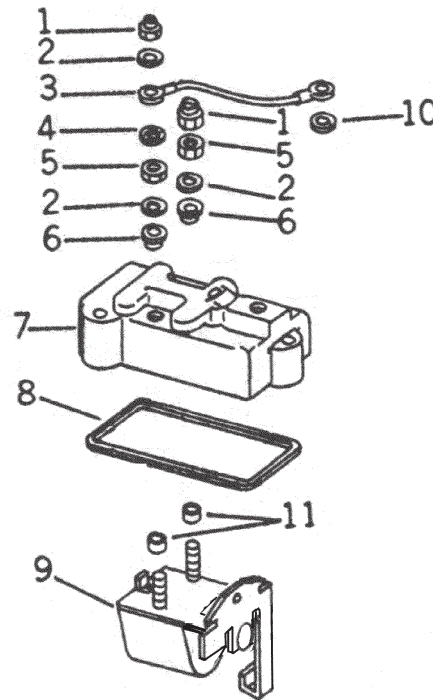

Reproduced by permission of Deere & Co., c2005. Deere & Company. All rights reserved.

T20527

KEY	PART NUMBER	QTY	DESCRIPTION	SERIAL NUMBER
••	RE37091	1	Hardware Kit (includes keys 1-6 & 10)	-
1	M63431	2	Lock Nut	-
2		3	Washer (not available separately)	-
3	AR50874	**	Ground Strap	-
4	R47077	1	Lock Washer	-
5		2	Nut (not available separately)	-
6		2	Washer (not available separately)	-
7	T11919	1	Cover (without penetrations for solenoid terminals- manual shut-off)	-
	26-41001	1	Cover (with penetrations for solenoid terminals)	-
8	T11918	1	Gasket	-
9	RE37089	1	Solenoid Assembly, 12 Volt (Generator Units - Energize-to-run, includes key 11)	-
	22-51000	1	Solenoid Assembly, 24 Volt (Generator Units - Energize-to-run, includes key 11)	-
	22-51002	1	Solenoid Assembly, 6 Volt (Propulsion Units - Energize-to-stop-12 Volt System use, includes key 11)	-
	22-51003	1	Solenoid Assembly, 12 Volt (Propulsion Units - Energize-to-stop-24 Volt System use, includes key 11)	-
10	12-H295	1	Internal Star Washer #10	-
11	T11937	2	Insulator	-
			**As required	

Cold Start Sensor & Harness - Cooling System

L1064D, M1064D, M40C2, NL1064D, M1064T1, M55C2, & NL1064T1

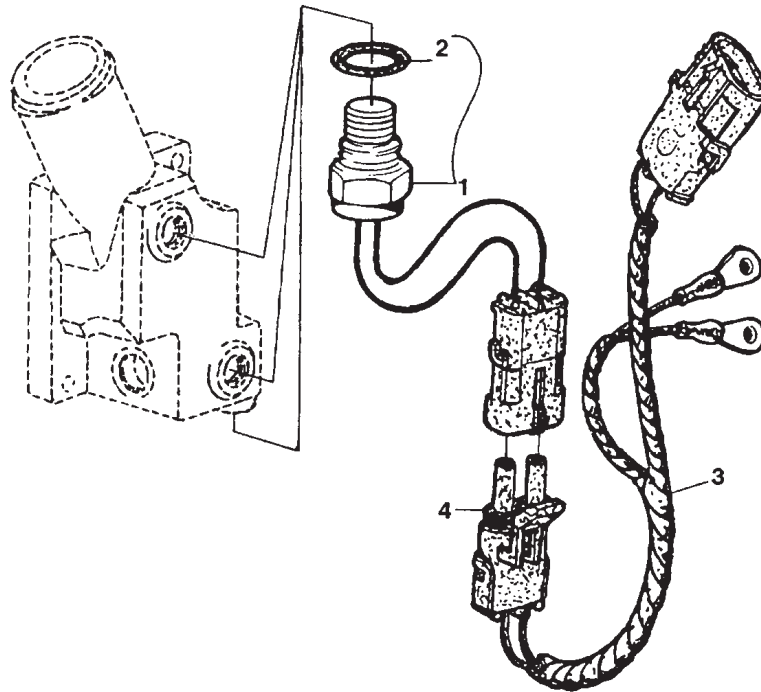

RGF7623

KEY	PART NUMBER	QTY	DESCRIPTION	SERIAL NUMBER
1	RE503242	1	Sensor & Wiring Harness (includes key #2)	-
2	51M7041	1	O-ring	-
3	RE66560	1	Wiring Harness	-
4	R78048	1	Connector	-

Cold Start Solenoid - Injection Pump

L1064D, M1064D, M40C2, NL1064D, M1064T1, M55C2, & NL1064T1

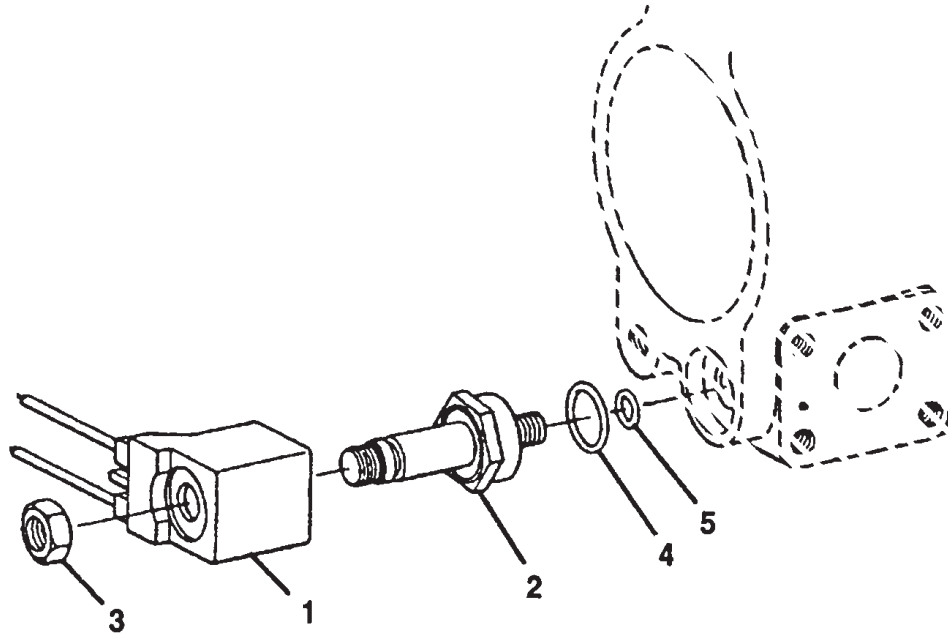

RGP6039

KEY	PART NUMBER	QTY	DESCRIPTION	SERIAL NUMBER
1	22-51004	1	Solenoid Valve Coil 12 Volt	-
	22-51006	1	Solenoid Valve Coil 24 Volt	-
2	R501516	1	Valve	-
3	RE502819	1	Nut	-
4	R501519	1	Seal	-
5	R502076	1	Back-up Ring (L1064D, M1064T1, M55C2, NL1064T1)	-
	R77551	1	O-ring (M1064D, M40C2, NL1064D)	-

GROUP 5 - ELECTRICAL SYSTEMS

12 Volt/ 65 Amp Medium Frame Alternator

L- M1064D, M40C2, M- NL1064T1&T2, M55C2, M65C2, L- M1064A, NL1064H1, M1064H, & NL1064H1

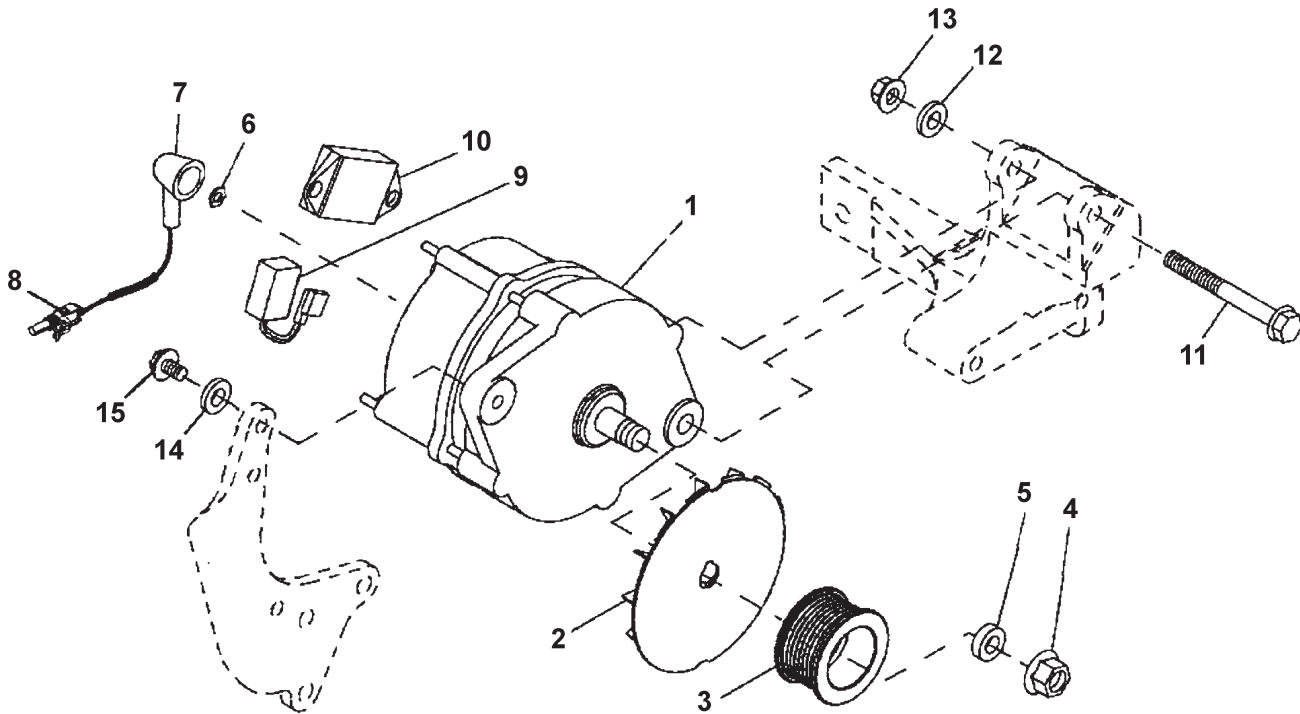

Reproduced by permission of Deere & Co., c2005. Deere & Company. All rights reserved.

RGP8260

KEY	PART NUMBER	QTY	DESCRIPTION	SERIAL NUMBER
••	22-49531	1	Alternator Assembly (includes keys #1-10)	-
1	AT173624	1	Alternator 12 Volt 65 Amp (see mounting detail)	-
2	T158584	1	Fan	-
3	R501486	1	Pulley	-
4	14M7158	1	Nut	-
5	T10745	1	Washer	-
6	14M7297	1	Nut, M5	-
7	RE505489	1	Wiring Harness	-
8	RE12362	1	Electrical Connector Assembly	-
9	H144095	1	Capacitor	-
10	H144094	1	Voltage Regulator	-
11	19M7812	1	Screw	-
12	R64525	1	Thrust Washer	-
13	14M7296	1	Flange Nut	-
14	R48808	1	Washer	-
15	19M7867	1	Capscrew, M8 x 25	-

24Volt/ 45 Amp Medium Frame Alternator

L- M- NL1064D, M40C2, M- NL1064T1&T2, M55C2, M65C2, L- M1064A, NL1064H1, M1064H, & NL1064H2

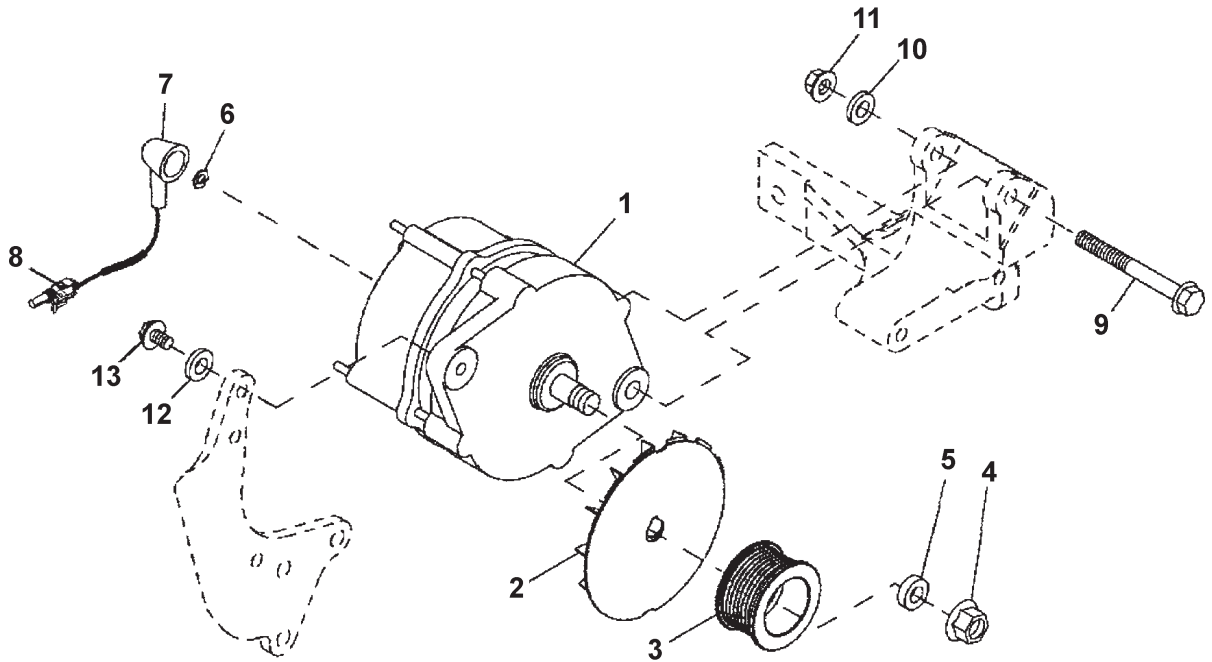

Reproduced by permission of Deere & Co., c2005. Deere & Company. All rights reserved.

RGP8262

KEY	PART NUMBER	QTY	DESCRIPTION	SERIAL NUMBER
••	22-49533	1	Alternator Assembly (includes keys #1-8)	-
1	TY24322	1	Alternator 24V/ 45 Amp (see mounting detail)	-
2	T158584	1	Fan	-
3	R501486	1	Pulley	-
4	14M7158	1	Nut	-
5	T10745	1	Washer	-
6	14M7297	1	Nut	-
7	RE505489	1	Wiring Harness	-
8	RE12362	1	Electrical Connector Assembly	-
9	19M7812	1	Screw	-
10	R64525	1	Thrust Washer	-
11	14M7296	1	Flange Nut	-
12	R48808	1	Washer	-
13	19M7867	1	Screw	-

GROUP 5 - ELECTRICAL SYSTEMS

Medium Frame Alternator & Mounting

L- M1064

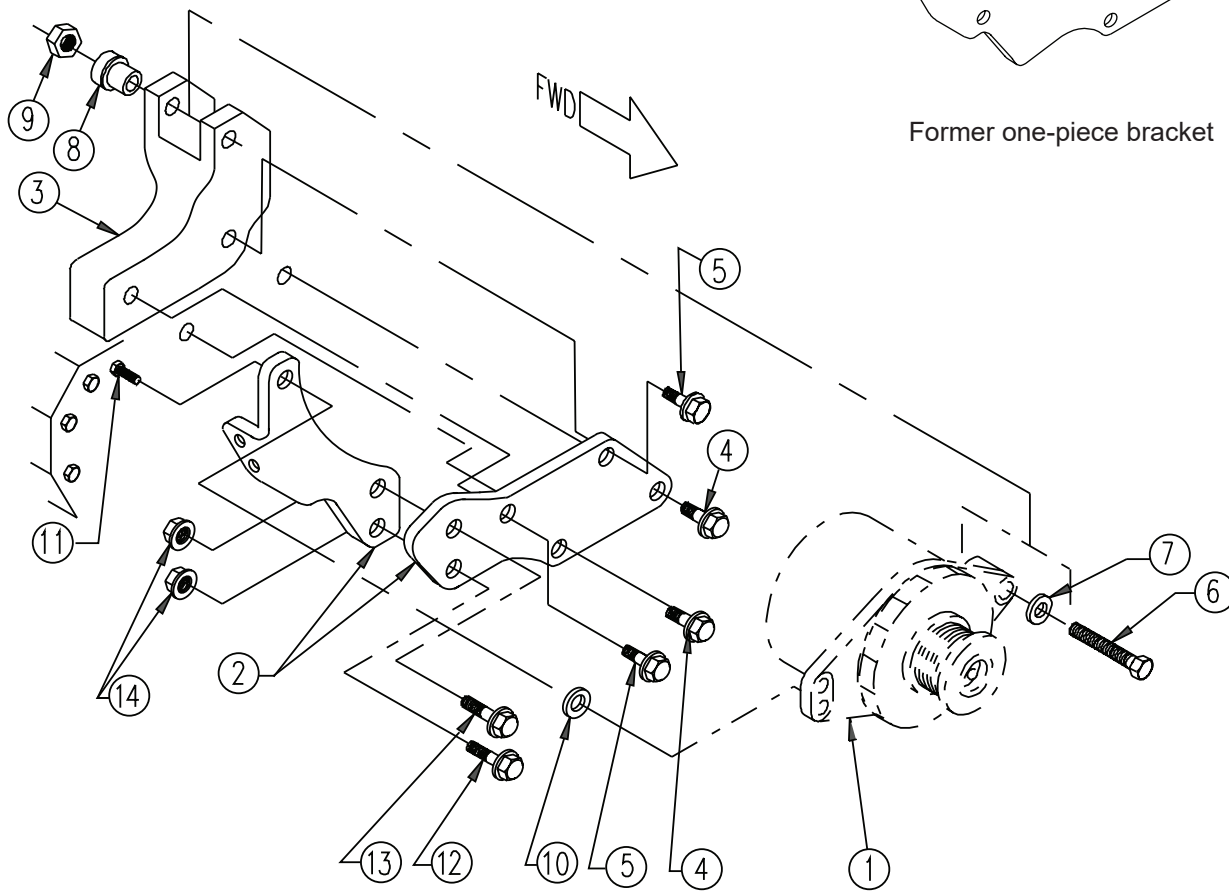

A-8530/ B-9502a

KEY	PART NUMBER	QTY	DESCRIPTION	SERIAL NUMBER
1	22-49531	1	Alternator, 12 Volt/ 65 Amp Isolated Ground (see parts detail)	-
	22-49533	1	Alternator, 24 Volt/ 45 Amp Isolated Ground (see parts detail)	-
2	23-49521	1	Bracket, Lower } Replaces former one piece bracket	-
	23-49522	1		Bracket, Upper }
3	R132166	1	Bracket	-
4	19M7801	2	Capscrew, Hex Head Flanged, M8 x 1.25 x 60 mm	-
5	19M7785	2	Capscrew, Hex Head Flanged, M10 x 1.5 x 25 mm	-
6	12-80088	1	Capscrew, Hex Head Flanged, M10 x 1.5 x 95 mm	-
7	R64525	1	Shim	-
8	R100377	1	Bushing	-
9	14-80811	1	Flange Nut	-
10	15-49501	**	Spacer	-
11	12-80753	1	Capscrew, Hex Head Flanged, M8 x 1.25 x 30 mm	-
12	19M7789	1	Capscrew, Hex Head Flanged, M12 x 1.75 x 30 mm	-
13	19M7790	1	Capscrew, Hex Head Flanged, M12 x 1.75 x 35 mm	-
14	14M7299	2	Hex Nut, Flanged M12 x 1.75	-
			**As required	

Medium Frame Alternator & Mounting

L- M1064

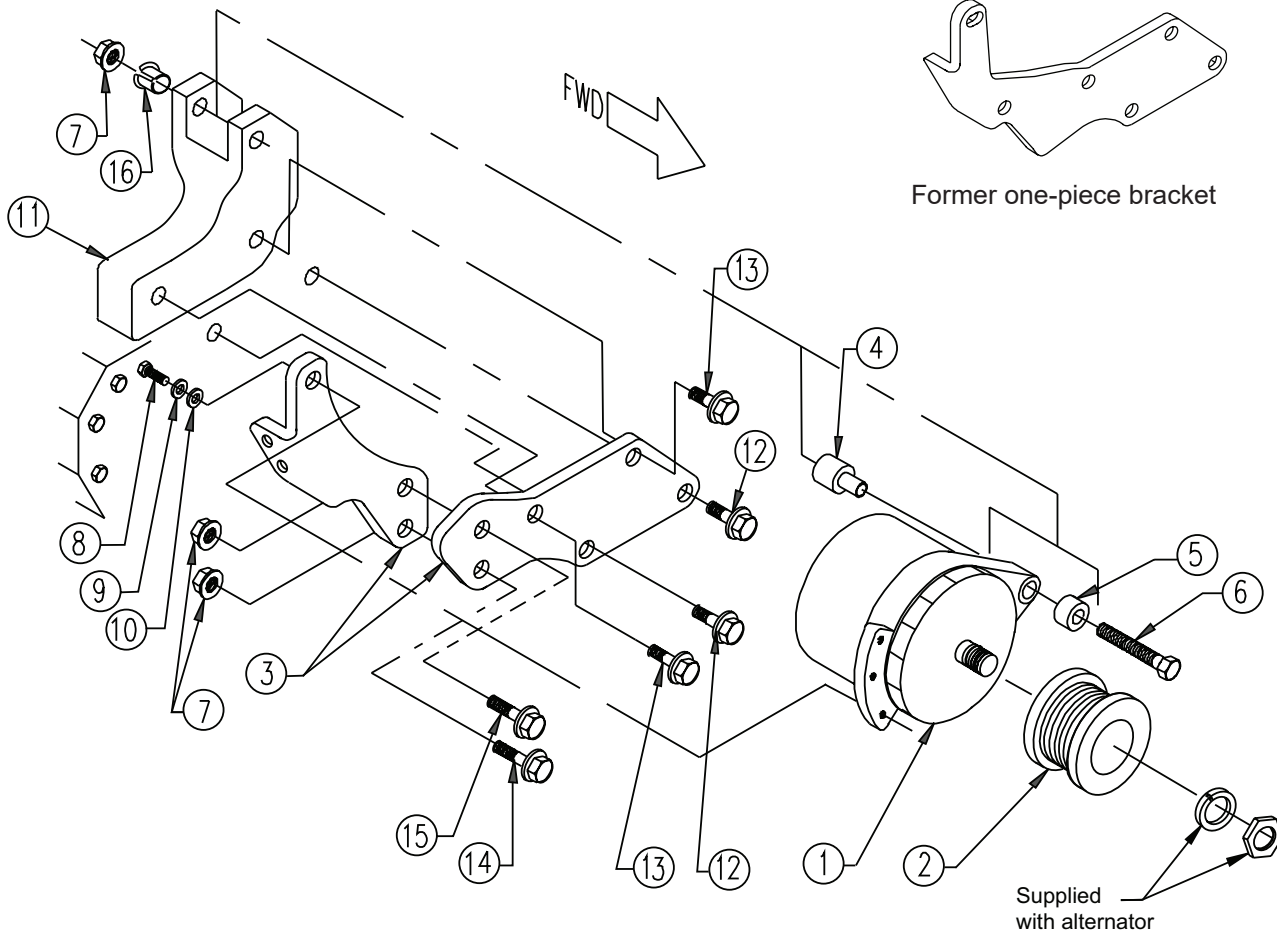

A-8530/ B-6405

KEY	PART NUMBER	QTY	DESCRIPTION	SERIAL NUMBER
1	22-40523	1	Alternator, 12 Volt/ 51 Amp Iso. Ground (replaces 22-40512)	-
	22-40513	1	Alternator, 24 Volt/ 35 Amp Isolated Ground	-
2	34-49502	1	Pulley 8 Groove 2.36" O.D. x 5/8" I.D.	-
3	23-49521	1	Bracket, Lower	} Replaces former one piece bracket
	23-49522	1	Bracket, Upper	
4	31-49501	1	Alternator Mounting Adapter	-
5	21-49503	1	Spacer	-
6	12-80088	1	Capscrew, Hex Head Flanged, M10 x 1.5 x 95 mm	-
7	14-80811	2	Hex Nut, Flanged M10 x 1.5 mm	-
8	12-00213	1	Capscrew, Hex Head 5/16-18 x 1- 1/4"	-
9	15-00202	1	Lock Washer, Helical 5/16	-
10	15-00221	1	Flat Washer, 5/16" SAE	-
11	R132166	1	Bracket	-
12	19M7801	2	Capscrew, Hex Head Flanged, M8 x 1.25 x 60 mm	-
13	19M7785	2	Capscrew, Hex Head Flanged, M10 x 1.5 x 25 mm	-
14	12-80832	1	Capscrew, Hex Head Flanged M10 x 1.5 x 30 mm	-
15	19M7835	1	Capscrew, Hex Head Flanged M10 x 1.5 x 35 mm	-
16	R100377	1	Bushing	-
17	22-70048	1	Diode Harness Addition (used only with 12V/ 51 Amp Alternator, not shown)	-

Medium Frame Alternator & Mounting

M1064H with 12V/ 65 Amp or 24V/ 45 Amp Alternator

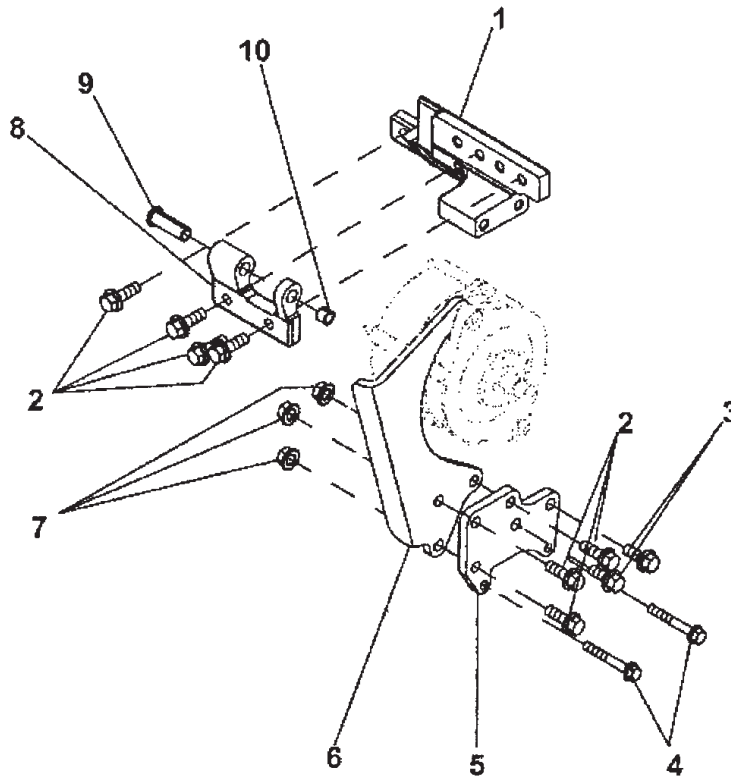

Reproduced by permission of Deere & Co., c2006. Deere & Company. All rights reserved.

RE517275SPA

KEY	PART NUMBER	QTY	DESCRIPTION	SERIAL NUMBER
1	R516584	1	Bracket	-
2	19M7786	7	Capscrew, M10 x 30 mm	-
3	19M7785	2	Capscrew, M10 x 25 mm	-
4	19M7801	2	Capscrew, M8 x 60 mm	-
5	R516510	1	Support	-
6	23-49516	1	Bracket	-
7	14M7296	3	Flange Nut, M10	-
8	R516574	1	Bracket	-
9	R134010	1	Bushing	-
10	R135423	1	Bushing	-

Medium Frame Alternator Mounting

NL1064D, T1, T2, H1, 12V/ 65 Amp or 24V/ 45 Amp

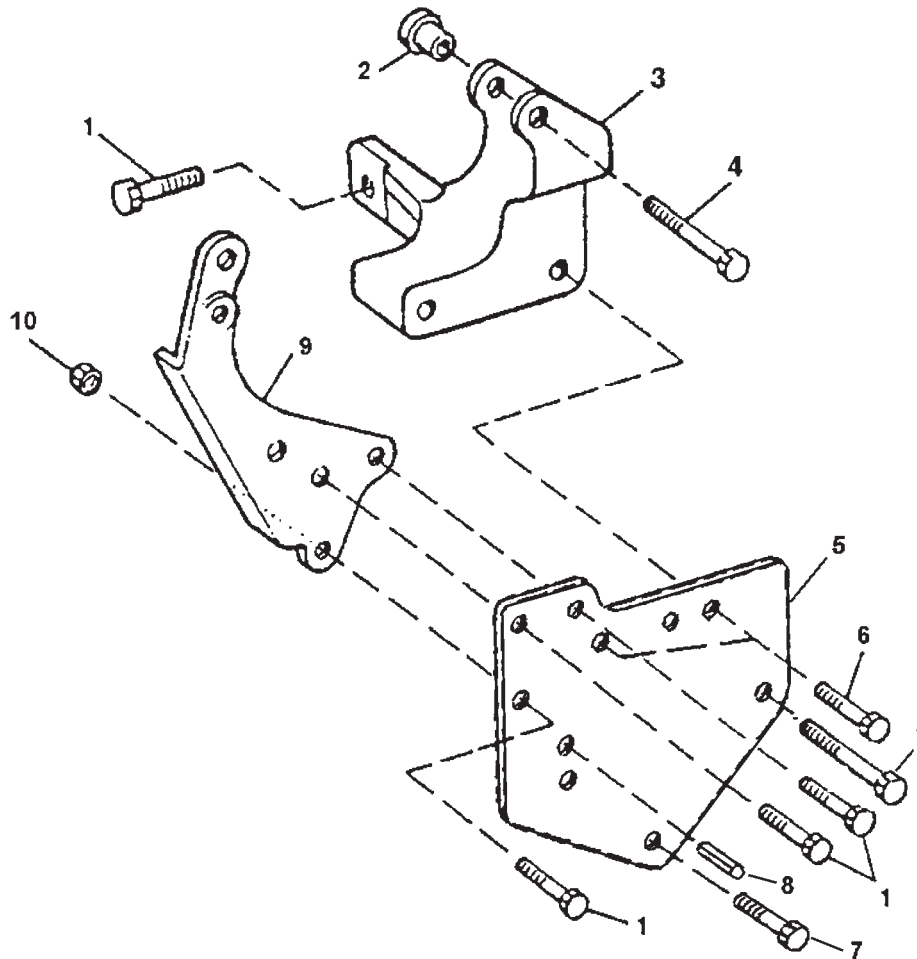

Reproduced by permission of Deere & Co., c2005. Deere & Company. All rights reserved.

RGP8623

KEY	PART NUMBER	QTY	DESCRIPTION	SERIAL NUMBER
1	19M7786	5	Capscrew, M10 x 30 mm	-
2	R100377	1	Bushing	-
3	R132166	1	Bracket	-
4	19M7812	1	Capscrew, Hex Head Flanged M10 x 1.5 x 100 mm	-
5	R132168	1	Support	-
6	19M7785	2	Capscrew, M10 x 25	-
7	19M7801	2	Capscrew, M8 x 60 mm	-
8	34M7061	1	Spring Pin	-
9	R132167	1	Bracket	-
10	14M7296	3	Flange Nut, M10	-

Medium Frame Alternator Mounting

NL1064H2 with 12V/ 65 Amp or 24V/ 45 Amp Alternator

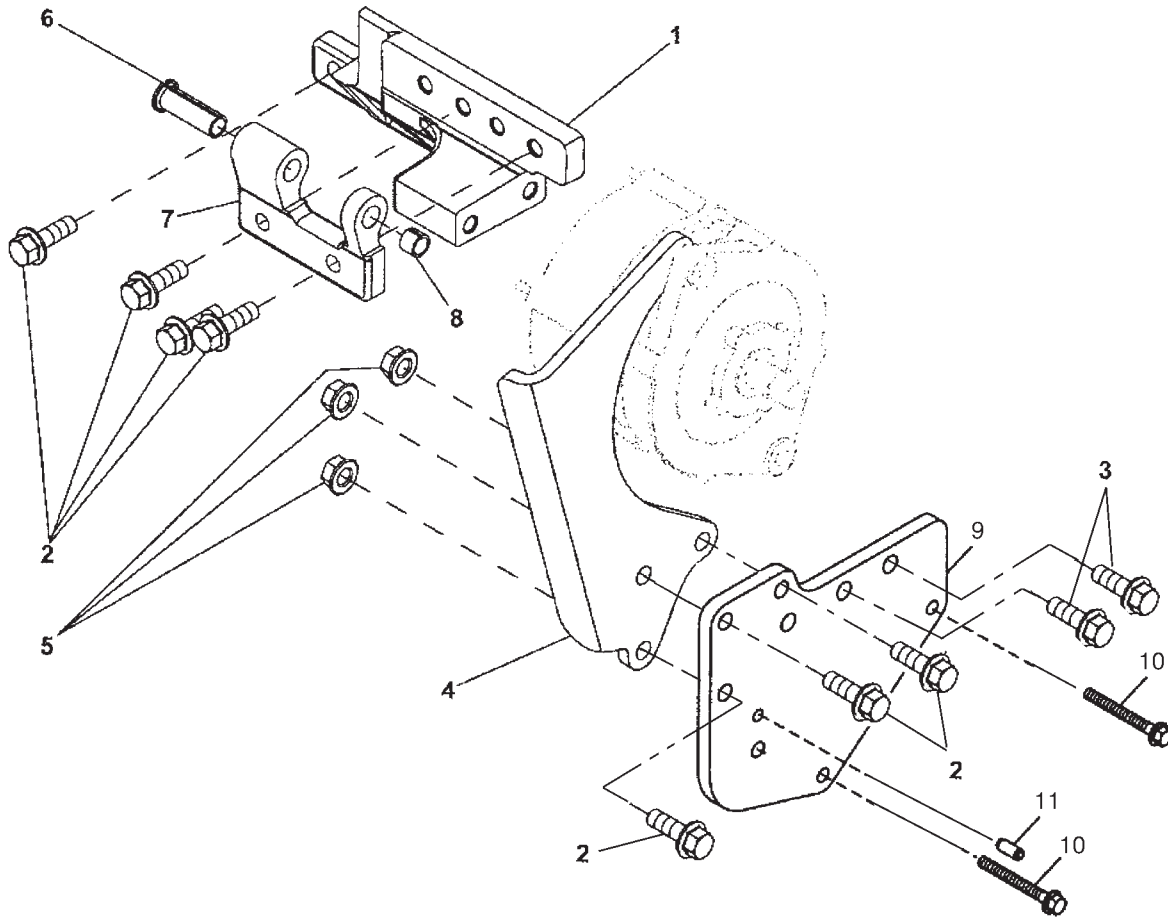

Reproduced by permission of Deere & Co., c2005. Deere & Company. All rights reserved.

RE517274SPA&RGP5656

KEY	PART NUMBER	QTY	DESCRIPTION	SERIAL NUMBER
1	R516584	1	Bracket	-
2	19M7786	7	Capscrew, M10 x 30 mm	-
3	19M7785	2	Capscrew, M10 x 25 mm	-
4	R516569	1	Strap	-
5	14M7296	3	Flange Nut, M10	-
6	R134010	1	Bushing	-
7	R516574	1	Bracket	-
8	R135423	1	Bushing	-
9	R516508	1	Support Bracket	-
10	19M7801	2	Capscrew, M8 x 60 mm	-
11	34M7061	1	Spring Pin	-

Large Frame Alternators & Mounting

L- M1064D, M40C2, M1064T1&T2, M55C2, M65C2,
and L- M1064A

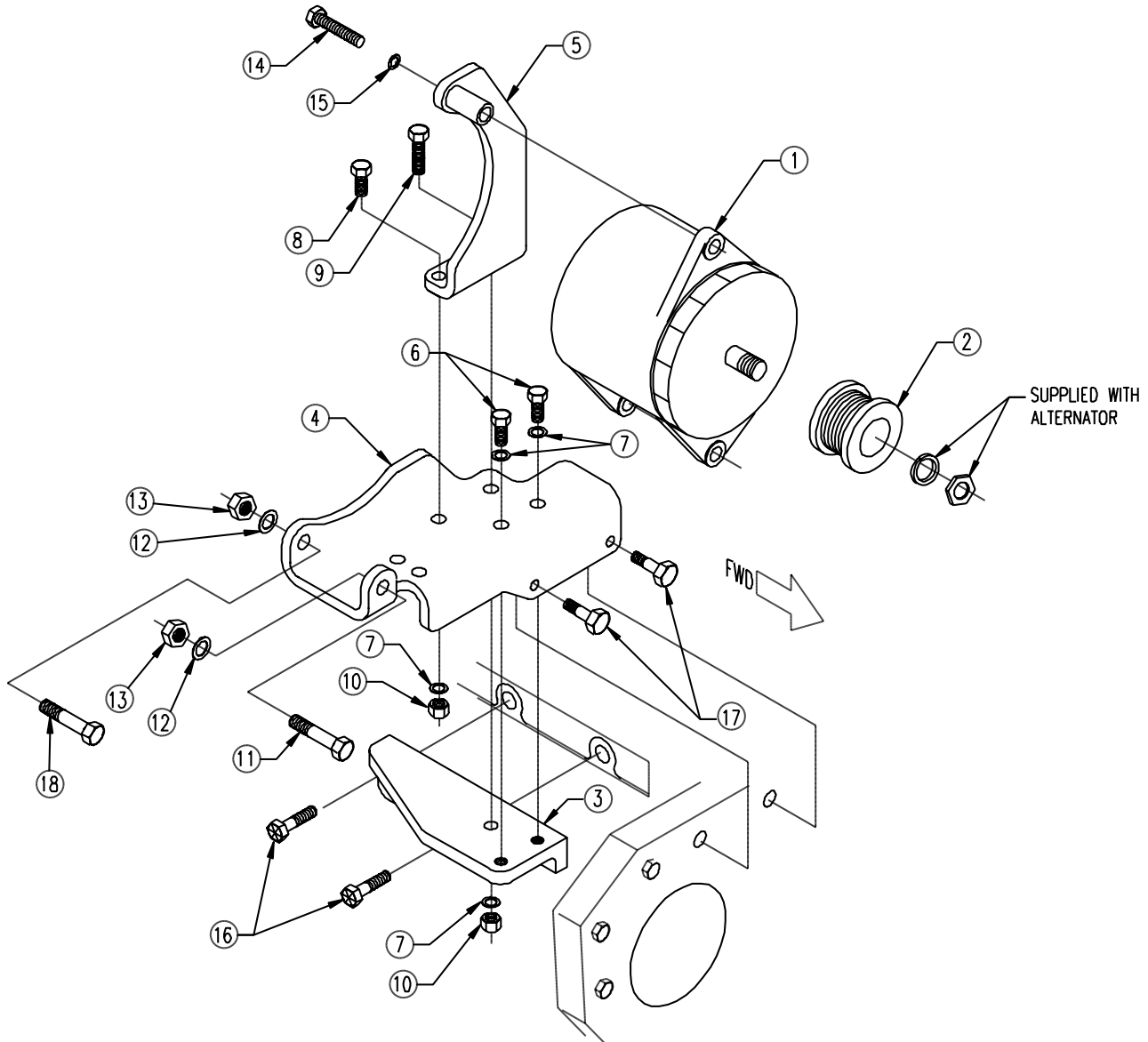

A-8609, A-8610/ C-4545

Large Frame Alternators & Mounting

L- M1064D, M40C2, M1064T1&T2, M55C2, M65C2,
and L- M1064A

KEY	PART NUMBER	QTY	DESCRIPTION	SERIAL NUMBER
1	22-40282	1	Alternator, 12 Volt 140 Amp Isolated Ground	-
	22-40277	1	Alternator, 24 Volt 75 Amp Isolated Ground	-
2	34-49503	1	8 Groove Pulley, 3-1/4" O.D. x 7/8" I.D.	-
3	23-49502	1	Alternator Support Mounting Bracket	-
4	23-49503	1	Alternator Mounting Bracket	-
5	23-49504	1	Alternator Mounting Bracket	-
6	12-00831	2	Capscrew, Hex Head Flanged, M10 x 1.5 x 25 mm	-
7	15-00802	4	Lock Washer, Helical, M10	-
8	12-00814	1	Capscrew, Hex Head, M10 x 1.5 x 35 mm	-
9	12-00812	1	Capscrew, Hex Head, M10 x 1.5 x 40 mm	-
10	14-00811	2	Hex Nut, M10 x 1.5	-
11	12-00515	1	Capscrew, Hex Head, 1/2 -13 x 1 -3/4"	-
12	15-00504	3	Flat Washer, 1/2" SAE	-
13	14-00512	2	Hex Nut, Nylock 1/2-13	-
14	12-00518	1	Capscrew, Hex Head, 1/2 -13 x 2 -1/2"	-
15	15-00502	1	Lock Washer, Helical 1/2"	-
16	19M7786	**	Capscrew, Hex Head Flanged, M10 x 1.5 x 30 mm	-
17	19M7801	2	Capscrew, Hex Head Flanged, M8 x 1.25 x 60 mm	-
18	12-00516	1	Capscrew, Hex Head 1/2 -13 x 2"	-
			**As required	

Large Frame Alternator & Mounting

24 Volt/ 100 Amp, L- M1064D, M40C2, M1064T1&T2, M55C2, M65C2, L-M1064A

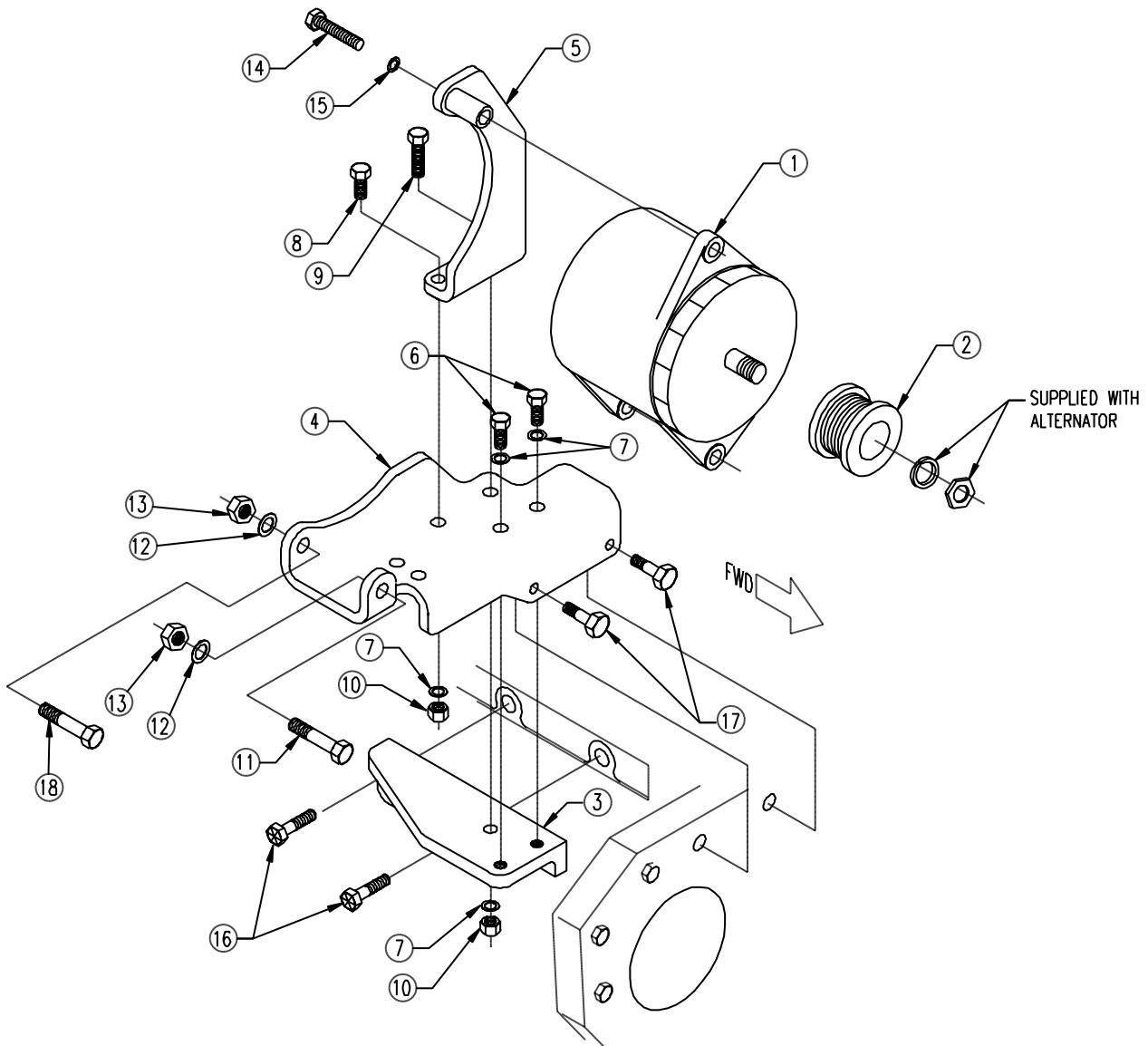

A-1023/ C-4545

Large Frame Alternator & Mounting

24 Volt/ 100 Amp, L- M1064D, M40C2, M1064T1&T2, M55C2, M65C2, L-M1064A

KEY	PART NUMBER	QTY	DESCRIPTION	SERIAL NUMBER
1	22-45018	1	Alternator, 24 Volt 100 Amp Isolated Ground	-
2	34-40002	1	8 Groove Pulley, 3-1/4" O.D. x 7/8" I.D.	-
3	23-49502	1	Alternator Support Mounting Bracket	-
4	23-49503	1	Alternator Mounting Bracket	-
5	23-49505	1	Alternator Mounting Bracket	-
6	12-00831	2	Capscrew, Hex Head Flanged, M10 x 1.5 x 25 mm	-
7	15-00802	4	Lock Washer, Helical, M10	-
8	12-00814	1	Capscrew, Hex Head, M10 x 1.5 x 35 mm	-
9	12-00812	1	Capscrew, Hex Head, M10 x 1.5 x 40 mm	-
10	14-00811	2	Hex Nut, M10 x 1.5	-
11	12-00515	1	Capscrew, Hex Head, 1/2 -13 x 1 -3/4"	-
12	15-00504	3	Flat Washer, 1/2" SAE	-
13	14-00512	2	Hex Nut, Nylock 1/2 -13	-
14	12-00518	1	Capscrew, Hex Head, 1/2 -13 x 2 -1/2"	-
15	15-00502	1	Lock Washer, Helical 1/2"	-
16	19M7786	**	Capscrew, Hex Head Flanged, M10 x 1.5 x 30 mm (**As required)	-
17	19M7801	2	Capscrew, Hex Head Flanged, M8 x 1.25 x 60 mm	-
18	12-00516	1	Capscrew, Hex Head 1/2 -13 x 2"	-

Large Frame Alternator & Mounting

M1064H

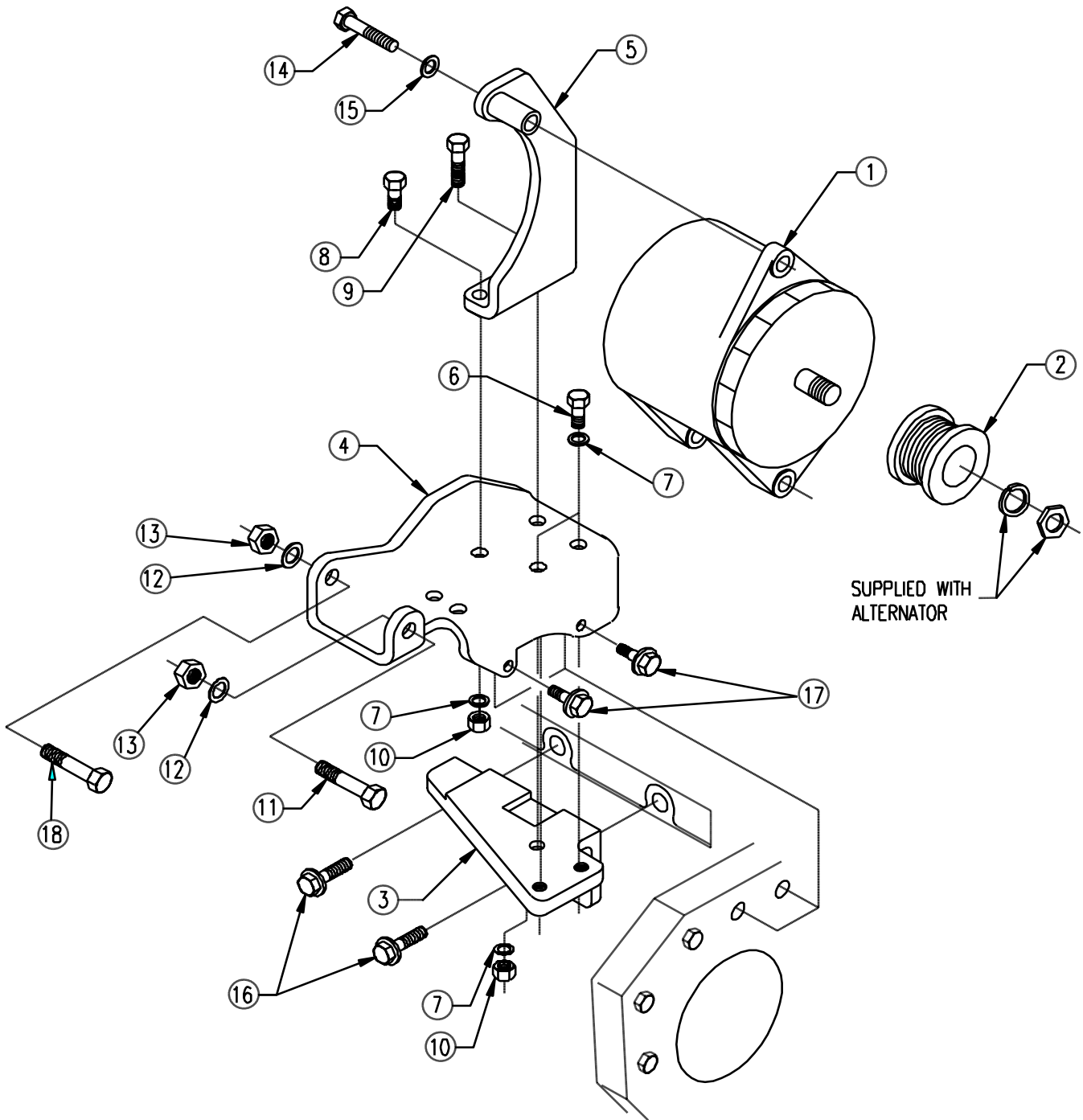

A-10389, A-10390/ C-5762

Large Frame Alternator & Mounting

M1064H

KEY	PART NUMBER	QTY	DESCRIPTION	SERIAL NUMBER
1	22-40282	1	Alternator, 12 Volt/ 140 Amp Isolated Ground	-
	22-40277	1	Alternator, 24 Volt/ 75 Amp Isolated Ground	-
2	34-49503	1	8 Groove Pulley, 3-1/4" O.D. x 7/8" I.D.	-
3	23-49509	1	Alternator Support Mounting Bracket	-
4	23-49510	1	Alternator Mounting Bracket	-
5	23-49508	1	Alternator Mounting Bracket	-
6	12-00831	2	Capscrew, Hex Head Flanged, M10 x 1.5 x 25 mm	-
7	15-00802	4	Lock Washer, Helical, M10	-
8	12-00814	1	Capscrew, Hex Head, M10 x 1.5 x 35 mm	-
9	12-00812	1	Capscrew, Hex Head, M10 x 1.5 x 40 mm	-
10	14-00811	2	Hex Nut, M10 x 1.5	-
11	12-00515	1	Capscrew, Hex Head, 1/2 -13 x 1 -3/4"	-
12	15-00504	3	Flat Washer, 1/2" SAE	-
13	14-00512	2	Hex Nut, Nylock 1/2 -13	-
14	12-00518	1	Capscrew, Hex Head, 1/2 -13 x 2 -1/2"	-
15	15-00502	1	Lock Washer, Helical 1/2"	-
16	19M7786	2	Capscrew, Hex Head Flanged, M10 x 1.5 x 30 mm	-
17	19M7801	2	Capscrew, Hex Head Flanged, M8 x 1.25 x 60 mm	-
18	12-00516	1	Capscrew, Hex Head 1/2 -13 x 2"	-

Harness Assembly with Circuit Breaker & Relay Panel

L1064D

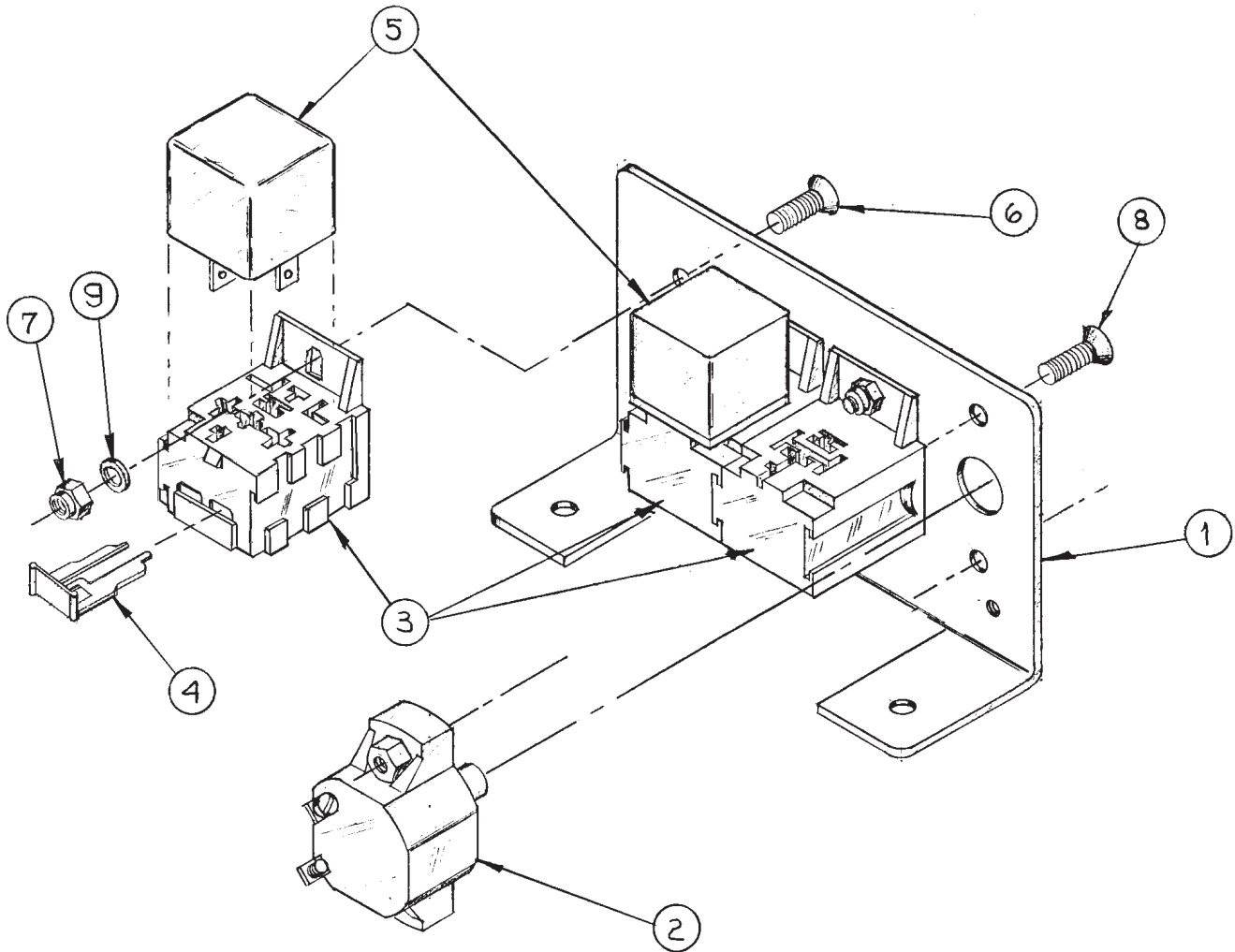

A-8804 / B-3139z

KEY	PART NUMBER	QTY	DESCRIPTION	SERIAL NUMBER
••	22-49402	1	Wire Harness Assembly with Relay Bases (w/o Relays)	-
1	23-40019	1	Bracket	-
2	22-41070	1	40 Amp Circuit Breaker	-
3	22-40391	2	Relay Base	-
4	22-40393	2	Terminal Retainer	-
5	22-42047	2	12 Volt Start Relay	-
	22-40085	2	24 Volt Start Relay	-
6	12-03010	2	Machine Screw, 10 -32 x 3/8", 100°	-
7	14-00001	4	Hex Nut, 10 -32	-
8	12-03011	2	Counter Machine Screw, 10 -32 x 3/4" 100° Flathead	-
9	15-00032	2	Flat Washer #10	-

12 & 24 Volt Relay Logic Board

Manual Start

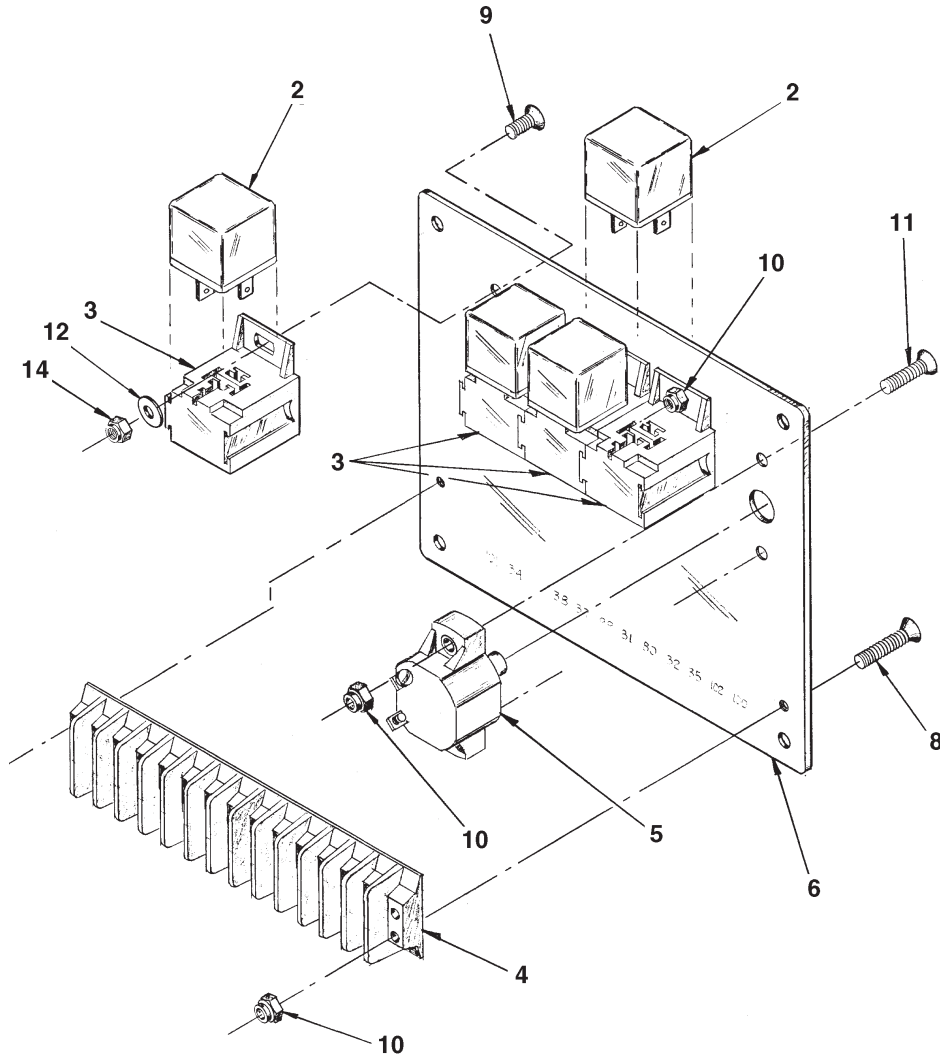

A-8851, A-8852/ C-2041

KEY	PART NUMBER	QTY	DESCRIPTION	SERIAL NUMBER
••	22-70083	1	12V Relay Logic Board, Manual Start (Includes all keys)	-
••	22-70084	1	24V Relay Logic Board, Manual Start (Includes all keys)	-
1	22-41060	2	6 amp Diode (not shown)	-
2	22-42047	4	12V Relay SPDT	-
	22-40085	4	24V Relay SPDT	-
3	22-40391	4	Relay Base	-
4	22-40193	1	12 Connection Terminal Board, 600 VAC	-
5	22-40018	1	10 amp Circuit Breaker	-
6	28-40001	1	Relay Board Mounting Plate	-
7	22-40393	4	Terminal Retainer Clip (not shown)	-
8	12-00083	2	Machine Screw, Flat Head Countersunk #8-32 x 3/4"	-
9	12-00082	4	Machine Screw, Flat Head Countersunk #8-32 x 3/8"	-
10	14-00003	4	Hex Nut, Nylock, #8 x 32	-
11	12-40225	2	Machine Screw, Flat Head Countersunk, #8-32 x 7/8"	-
12	15-00001	4	Flat Washer, #8	-
13	22-40347	1	Wire Harness, Manual Start (not shown)	-
14	14-00000	4	Hex Nut #8- 32	-

GROUP 5 - ELECTRICAL SYSTEMS

12 & 24 Volt Relay Logic Board

Autostart

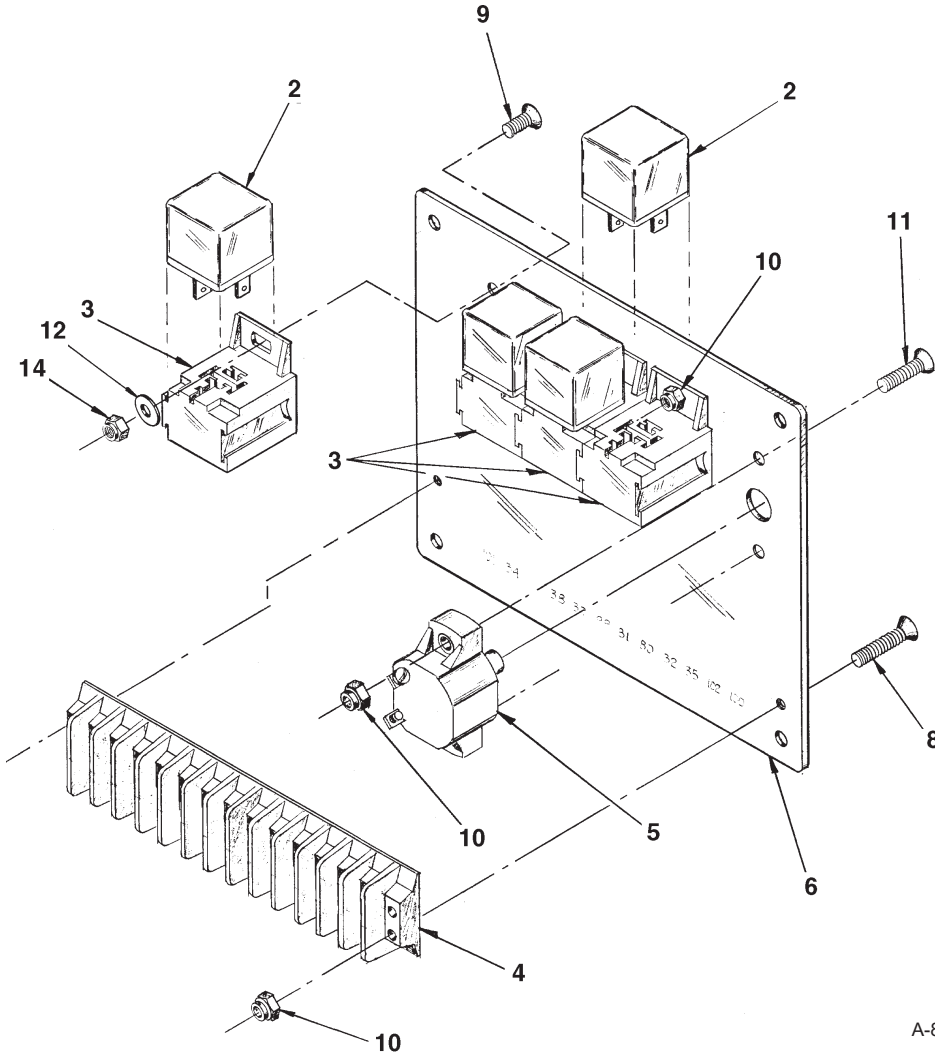

A-8854, A-8855/ C-2041

KEY	PART NUMBER	QTY	DESCRIPTION	SERIAL NUMBER
••	22-70086	1	12V Relay Logic Board, Autostart (Includes all keys)	-
••	22-70087	1	24V Relay Logic Board, Autostart (Includes all keys)	-
2	22-42047	4	12V Relay SPDT	-
	22-40085	4	24V Relay SPDT	-
3	22-40391	4	Relay Base	-
4	22-40193	1	12 Connection Terminal Board, 600 VAC	-
5	22-40018	1	10 amp Circuit Breaker	-
6	28-90018	1	Relay Board Mounting Plate	-
7	22-40393	4	Terminal Retainer Clip (not shown)	-
8	12-00083	2	Machine Screw, Flat Head Countersunk #8-32 x 3/4"	-
9	12-00082	4	Machine Screw, Flat Head Countersunk #8-32 x 3/8"	-
10	14-00003	4	Hex Nut, Nylock, #8 x 32	-
11	12-40225	2	Machine Screw, Flat Head Countersunk, #8-32 x 7/8"	-
12	15-00001	4	Flat Washer, #8	-
13	22-40392	1	Wire Harness, Autostart (not shown)	-
14	14-00000	4	Hex Nut #8- 32	-

12 & 24 Volt Relay Logic Board

Autostart/ Energise-To-Stop/
Redundant Power Supply

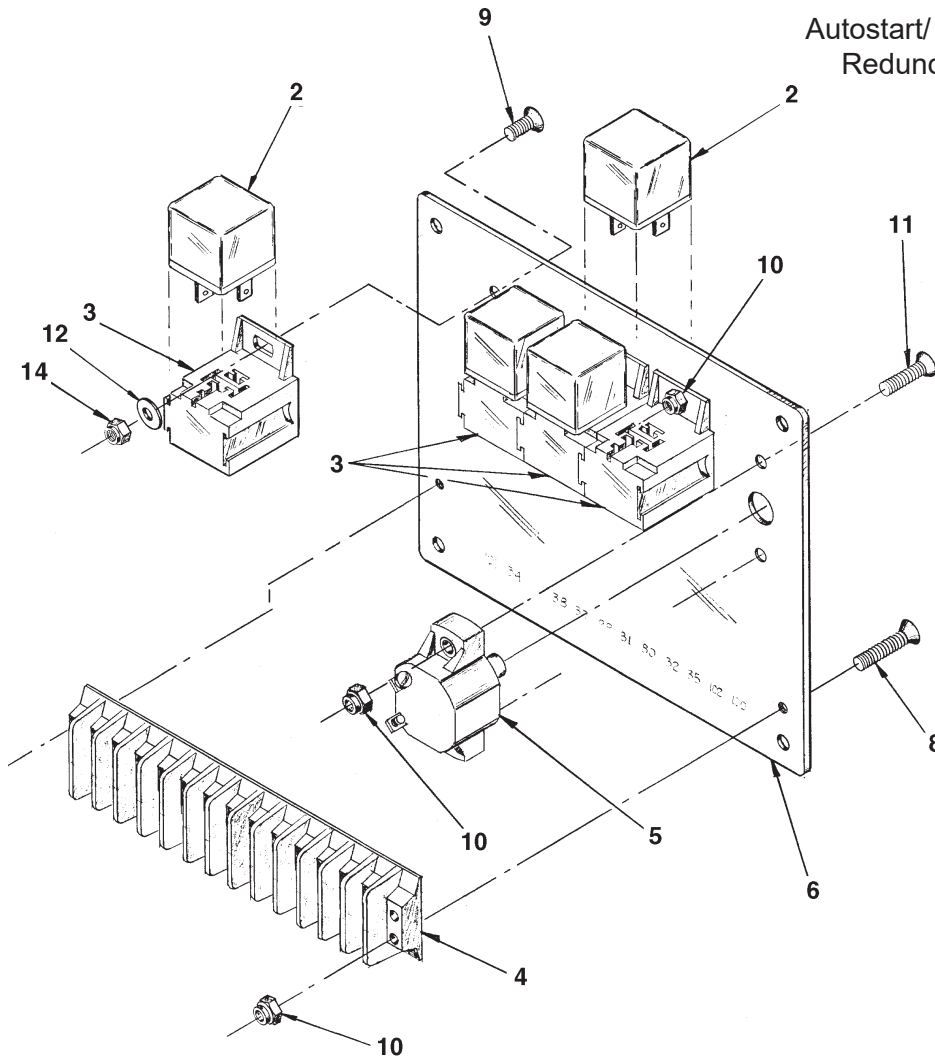

A-11644, A-11645/ C-2041

KEY	PART NUMBER	QTY	DESCRIPTION	SERIAL NUMBER
••	22-70093	1	12V Relay Logic Board, Autostart (Includes all keys)	-
••	22-70094	1	24V Relay Logic Board, Autostart (Includes all keys)	-
1	22-00089	1	Number Strip (not shown)	-
2	22-42047	3	12V Relay SPDT	-
	22-40085	3	24V Relay SPDT	-
3	22-40391	3	Relay Base	-
4	22-40193	1	12 Connection Terminal Board, 600 VAC	-
5	22-40018	1	10 amp Circuit Breaker	-
6	28-40001	1	Relay Board Mounting Plate	-
7	22-40393	3	Terminal Retainer Clip (not shown)	-
8	12-00083	2	Machine Screw, Flat Head Countersunk #8-32 x 3/4"	-
9	12-00082	3	Machine Screw, Flat Head Countersunk #8-32 x 3/8"	-
10	14-00003	3	Hex Nut, Nylock, #8 x 32	-
11	12-40225	2	Machine Screw, Flat Head Countersunk, #8-32 x 7/8"	-
12	15-00001	4	Flat Washer, #8	-
13	22-40420	1	Wire Harness, Autostart (not shown)	-
14	14-00000	3	Hex Nut #8- 32	-

GROUP 5 – ELECTRICAL SYSTEM

NEMA 3R DC Electrical Enclosure & Relay Panel

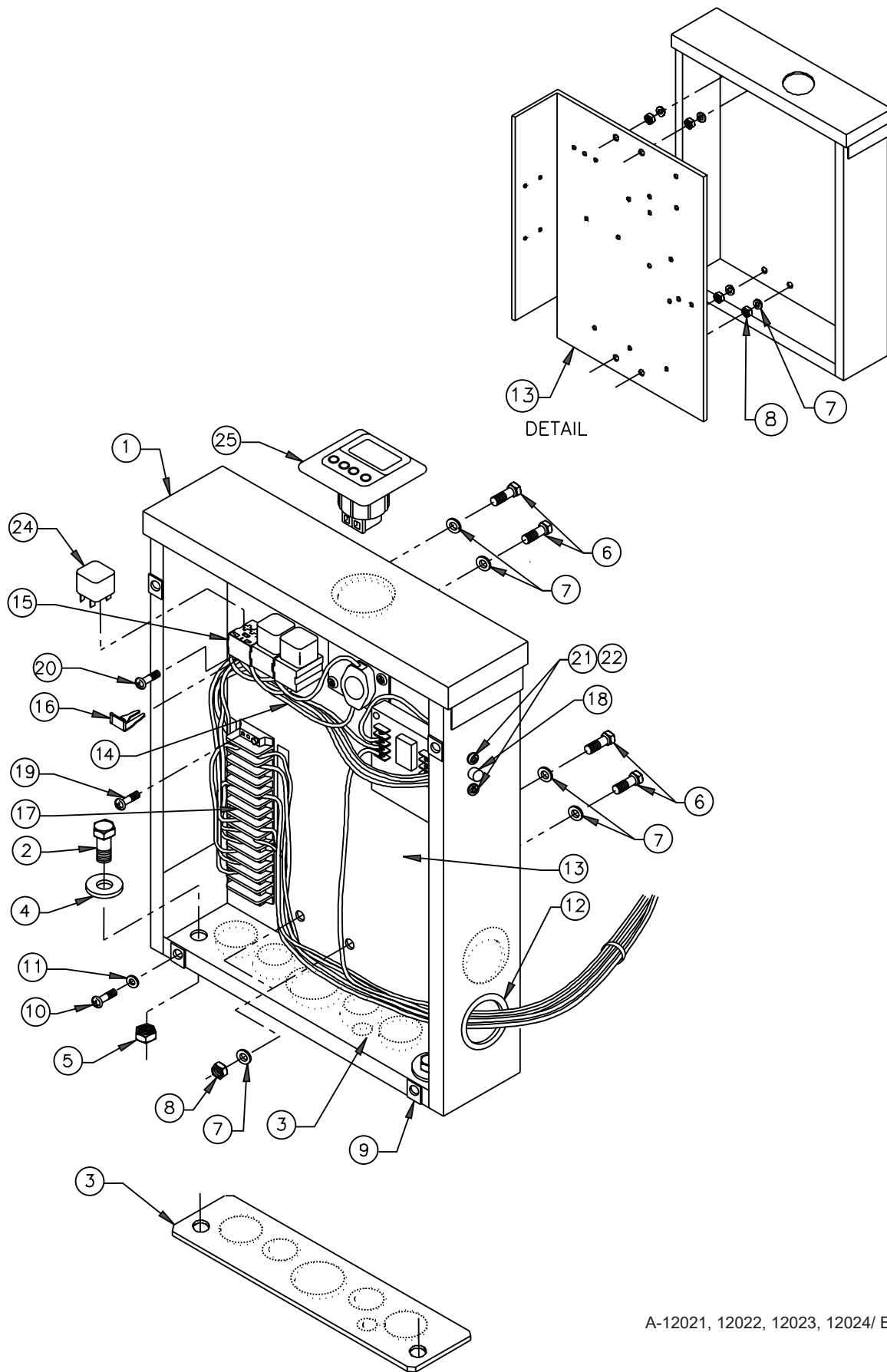

A-12021, 12022, 12023, 12024/ B-9556

NEMA 3R DC Electrical Enclosure & Relay Panel

KEY	PART NUMBER	QTY	DESCRIPTION	SERIAL NUMBER
••	22-70183	1	Relay Panel Assembly, Manual Start (includes keys #13-23)	-
••	22-70186	1	Relay Panel Assembly, Autostart (includes keys #13-23)	-
••	22-70193	1	Relay Panel Assembly, Energise-to-stop & Redundant Power Supply (includes keys #13-23)	-
1	39-40047	1	Enclosure, NEMA 3R (former # 39-42036)	-
	28-40048	1	Cover	-
2	12-00832	2	Capscrew, Hex Head M10 x 1.5 x 30 mm	-
3	28-49502	1	Plate, D.C. Enclosure Mtg.	-
4	15-00014	2	Head/ Tail Washer	-
5	14-00812	2	Hex Nut, Nylock M10 x 1.5 Class 8	-
6	12-01131	4	Capscrew, Hex Head M6 x 1.0 x 20 mm	-
7	15-00008	**	Flat Washer M6	-
8	14-04803	8	Hex Nut, Nylock M6 x 1.0 Class 8	-
9	00-49503	4	Receptacle, Screw Retainer	-
10	12-72006	4	Sheet Metal Screw, Truss Head Phillips #10	-
11	15-00036	**	Flat Washer #10 Nylon	-
12	00-73109	2	Grommet 1-1/2" ID x 2-1/8" OD	-
13	28-49501	1	Back Plane	-
14	22-99537	1	Harness Assembly, Manual Start (includes key #23)	-
	22-99538	1	Harness Assembly, Autostart	-
	22-99539	1	Harness Assembly, Autostart with Redundant Power Supply	-
15	22-40391	3	Relay Base (without retainer)	-
16	22-40393	3	Terminal Retainer	-
17	22-41069	1	Terminal Strip	-
18	22-40018	1	Circuit Breaker	-
19	12-00005	4	Machine Screw, Phillips #8-32 x 3/4" S/S	-
20	12-00004	2	Machine Screw, Phillips #8-32 x 3/8" S/S	-
21	12-42105	2	Machine Screw, Phillips #8-32 x 7/8" S/S	-
22	15-00001	2	Flat Washer #8	-
23	22-41060	4	Diode 6 Amp (for use with Harness 22-99537)	-
24	22-42047	**	Relay 12 Volt	-
	22-40085	**	Relay 24 Volt	-
			**As required	
			Optional	
25	37-90086	1	Powerview Module	-
26	22-99506	1	Wire Harness (not shown)	-

GROUP 5 - ELECTRICAL SYSTEMS

Drive Belt Tensioner

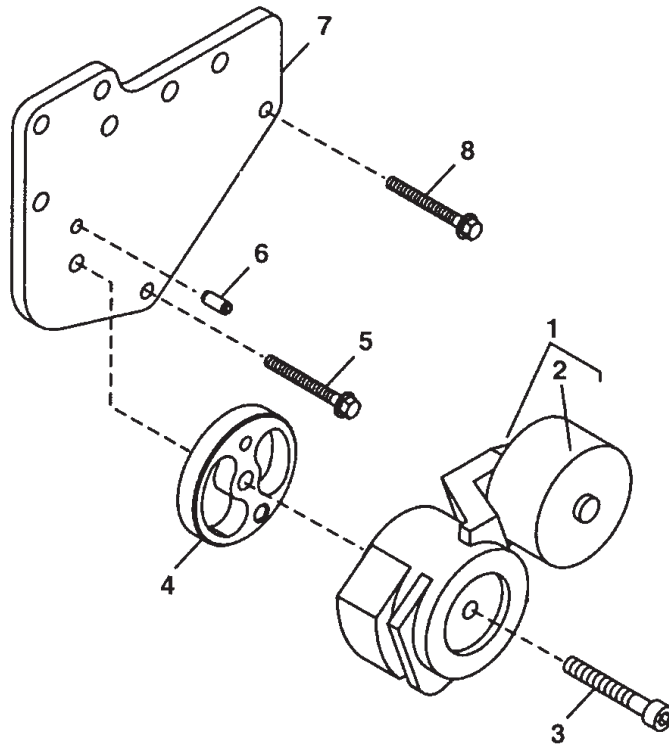

Reproduced by permission of Deere & Co., c2005. Deere & Company. All rights reserved.

RGF5656

KEY	PART NUMBER	QTY	DESCRIPTION	SERIAL NUMBER
1	RE518097	1	Tensioner (supercedes RE70536, requires 19M7811) *	-
	R70536	1	Tensioner (replaced by RE518097) *	-
2	R503813	1	Bolt	-
	RE505264	1	Idler	-
3	19M7811	1	Screw, M10 x 90 mm (use with RE518097)	-
	19M8131	1	Screw, M10 x 70 mm (use with RE70536)	-
4	R518210	1	Spacer (Marine - use with RE518097)	-
	R516623	1	Spacer (Industrial - use with RE518097)	-
	R500321	1	Spacer (Industrial - use with RE70536)	-
5	19M7801	1	Screw	-
6	34M7061	1	Spring Pin	-
7	R132168	1	Support Bracket (NL1064D, NL1064T1, NL1064T2, NL1064H1)	-
	R516508	1	Support Bracket (NL1064H2)	-
8	19M7801	1	Screw	-
			* Note: Requires spacer R518210 & screw 19M7811 when replacing earlier tensioner	

Manual Drive Belt Tensioner

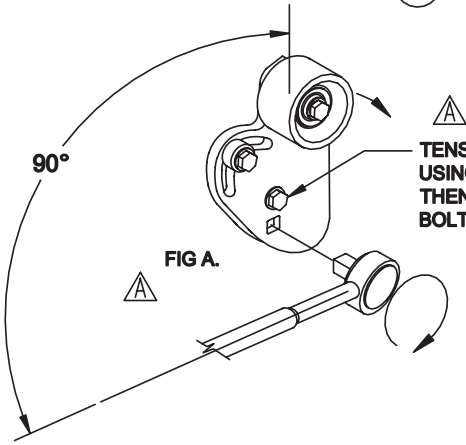
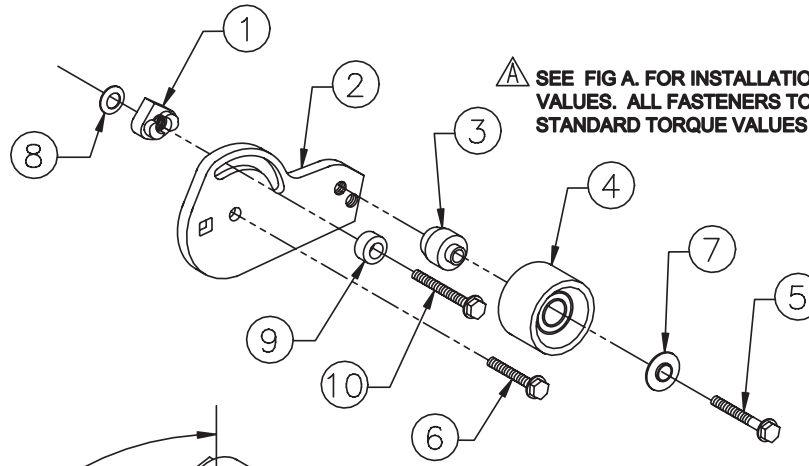

BOM: A-10727

A-10727/ B-9664A

KEY	PART NUMBER	QTY	DESCRIPTION	SERIAL NUMBER
••	34-09505	1	Manual Belt Tensioner Assembly (includes all keys)	-
1	R500710	1	Nut	-
2	23-49506	1	Bracket	-
3	R518518	1	Spacer*	-
4	RE518988	1	Idler Pulley (Single Bearing)	-
5	19M7805	1	Screw, M10 x 45 mm*	-
6	19M7785	1	Screw, M10 x 25 mm	-
7	R517324	1	Cover*	-
8	15-00701	1	Flat Washer M8	-
9	15-00708	1	Stud Washer M8	-
10	12-00754	1	Capscrew, Hex Head M8 x 1.25 x 85 mm	-
	19M7785	1	Screw, M10 x 25 mm (1064D, T1, T2, A)	-
<p>*Note: Items listed replace Spacer R501466, Two Bearing Idler Pulley RE505264, Sleeve R502079, and Capscrew 19M8528.</p>				

Idler Pulley & Mounting

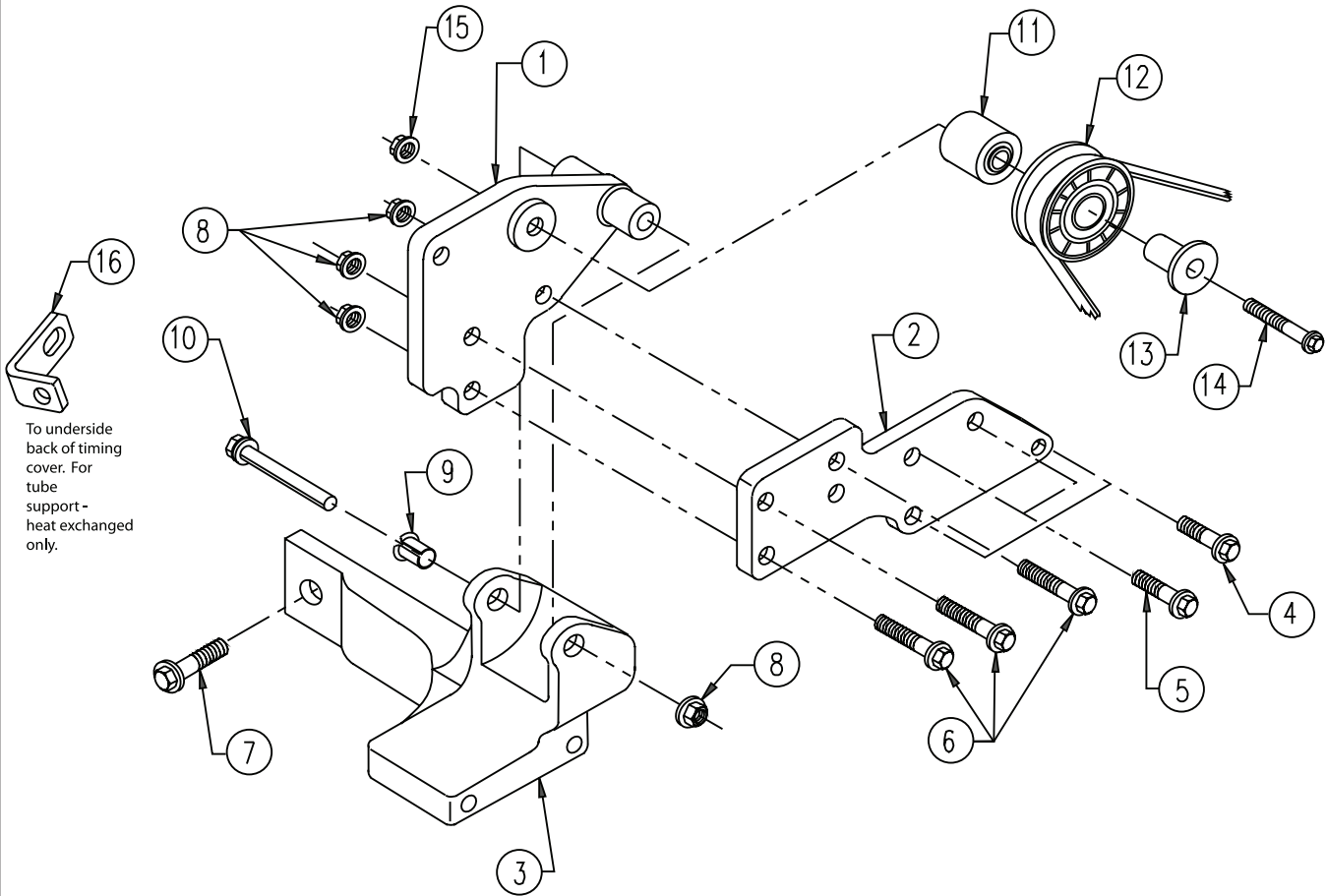

A-9878/ B-9398

KEY	PART NUMBER	QTY	DESCRIPTION	SERIAL NUMBER
1	23-79501	1	Bracket, Idler Mtg.	-
2	R132913	1	Support	-
3	R132166	1	Alternator Mounting Bracket	-
4	19M7801	2	Capscrew, Hex Head Flanged M8 x 1.25 x 60 mm	-
5	19M7785	2	Capscrew, Hex Head Flanged M10 x 1.5 x 25 mm	-
6	19M7835	3	Capscrew, Hex Head Flanged M10 x 1.5 x 35 mm	-
7	12-80832	2	Capscrew, Hex Head Flanged M10 x 1.5 x 30 mm	-
8	14-80811	4	Hex Nut, Flanged M10x 1.5	-
9	R100377	1	Bushing	-
10	12-80088	1	Capscrew, Hex Head Flanged M10 x 1.5 x 95 mm	-
11	R133643	1	Spacer	-
12	AT211041	1	Pulley, Poly-V	-
13	R502079	1	Sleeve	-
14	19M7812	1	Capscrew, Hex Head Flanged M10 x 1.5 x 100 mm	-
15	14-00812	1	Hex Nut, Nylock M10 x 1.5	-
16	23-71105	1	Bracket, Belt Guard Mtg., Side	-

Drive Belt Applications

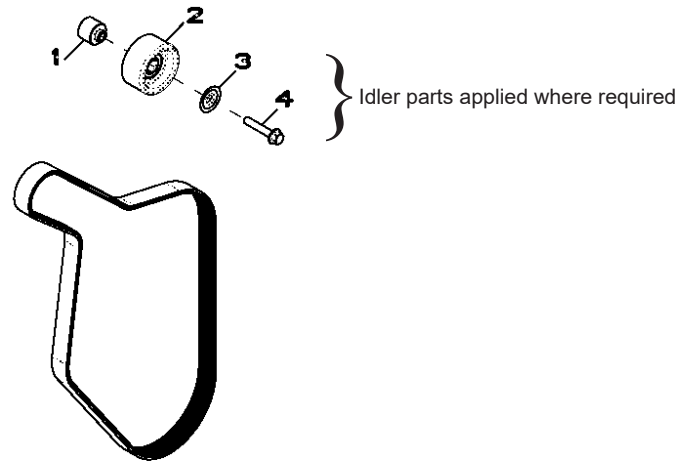

RE504029PCDE02

KEY	PART NUMBER	QTY	DESCRIPTION
			Standard or Optional Medium Frame Size Alternators 12V/ 65 Amp - 12V/51A - 24V/35A - 24V40A - 24V/45A
	40-09501	1	Drive Belt, L- M1064D (non-turbo) (formerly #R123439)
	R123463	1	Drive Belt, NL1064D (non-turbo)
	R123440	1	Drive Belt, M1064T1- T2- A (with turbo & auto belt tensioner)
	R123436	1	Drive Belt M1064T1- T2- A (with turbo & manual belt tensioner)
	R123462	1	Drive Belt, NL1064T1- T2 (with turbo)
	R123451	1	Drive Belt, M1064H, NL1064H1 (with turbo - all)
	R123457	1	Drive Belt, NL1064H2
	R123438	1	Drive Belt M1064T2MCA
			Optional Large Frame Size Alternators - 12V/ 130 Amp, 24V/ 75 Amp, 24V/ 100 Amp
	R123461	1	Drive Belt, L- M- NL1064D (non-turbo)
	R123457	1	Drive Belt, M1064T1- T2- A- H (with turbo)
			NOTE: Northern Lights supplies an additional spare belt on units equipped with front power take-off. Contact dealer or factory for belts on custom engineered accessories (unit serial number required).
1	R518518	1	Spacer
2	RE518988	1	Idler Pulley
3	R517324	1	Cover
4	19M8528	1	Capscrew, Hex Head Flanged M10 x 1.5 X 55mm

GROUP 5 - ELECTRICAL SYSTEMS

Main Instrument Panel 12 & 24 Volt

L1064D

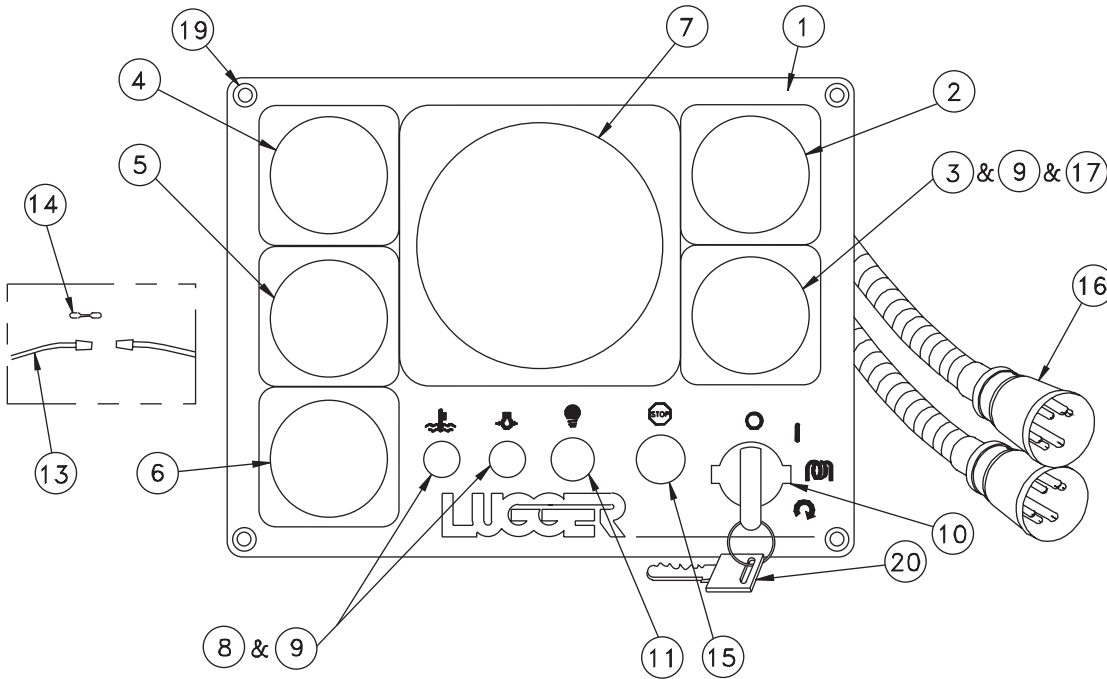

A-8803, A-9271/ B-4734-2

KEY	PART NUMBER	QTY	DESCRIPTION	SERIAL NUMBER
••	22-99400	1	Main Instrument Panel, 12 Volt (includes all keys)	-
••	22-99415	1	Main Instrument Panel, 24 Volt (includes all keys)	-
1	37-96801	1	Panel Plate	-
2	37-90022	1	Voltmeter, 12 Volt	-
	37-90023	1	Voltmeter, 24 Volt	-
3	37-90024	1	Hourmeter	-
4	37-90025	1	Temperature Gauge, 12 Volt	-
	37-90026	1	Temperature Gauge, 24 Volt	-
5	37-90033	1	Oil Pressure Gauge, 0-80 PSI, 12 Volt	-
	37-90034	1	Oil Pressure Gauge, 0-80 PSI, 24 Volt	-
6	22-40263	1	Alarm Horn 12/24 Volt	-
7	37-99401	1	Tachometer, 0-3000 RPM, 12 Volt	-
	37-99402	1	Tachometer, 0-3000 RPM, 24 Volt	-
8	22-44851	2	Fault Lamp Holder, Amber	-
9	22-44852	**	Bulb, Clear 12 Volt	-
	22-44853	**	Bulb, Clear 24 Volt	-
10	37-94803	1	Key Switch	-
11	22-40247	1	Toggle Switch (for panel lights)	-
12	22-41060	2	Diode (not shown)	-
13	22-00044	1	Fuse Holder	-
14	22-41008	1	Fuse, 7-1/2 Amp	-
15	37-91007	1	Push Button	-
16	22-44859	2	Wire Harness	-
17	22-44861	1	Red Diffuser (for hourmeter)	-
19	12-90002	4	Screw, Self Tapping #8	-
20	37-96805	1	Key, Double Sided	-
			**As required	

Main Instrument Panel 12 & 24 Volt

L1064D & L1064T1

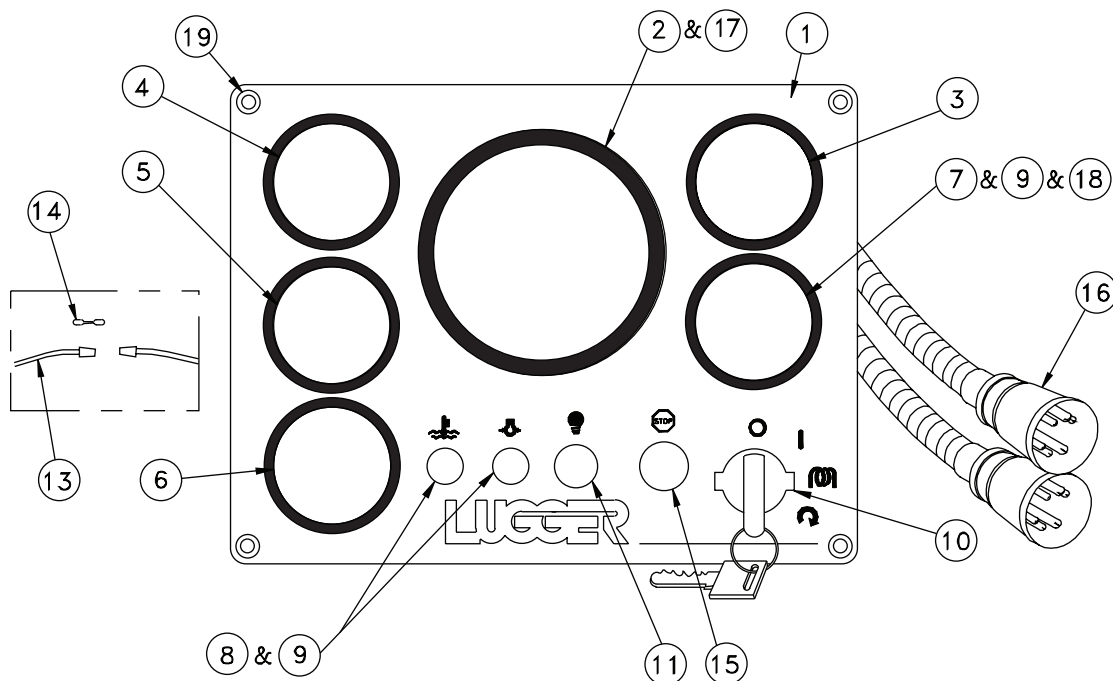

A-11651, A-11521 / B-4734-2changed

KEY	PART NUMBER	QTY	DESCRIPTION	SERIAL
••	22-99420	1	Main Instrument Panel, 12 Volt (includes all keys)	-
••	22-99425	1	Main Instrument Panel, 24 Volt (includes all keys)	-
1	28-90031	1	Plate, Main Instrument Panel	-
2	37-90069	1	Tachometer 0 -3500 RPM 12/24 Volt	-
3	37-90072-1	1	Voltmeter 8 -16 VDC	-
	37-90073-1	1	Voltmeter 18 -32 VDC	-
4	37-90075-1	1	Temperature Gauge 250°F 12 Volt	-
	37-90076-1	1	Temperature Gauge 250°F 24 Volt	-
5	37-90081-1	1	Oil Pressure Gauge 0 -80 PSI 12 Volt	-
	37-90082-1	1	Oil Pressure Gauge 0 -80 PSI 24 Volt	-
6	22-40263-1	1	Alarm Horn 12/ 24 Volt	-
7	37-90074-1	1	Hourmeter 12/ 24 Volt	-
8	22-44851	2	Lamp Holder, Amber Lens	-
9	22-44852	2	Bulb, Clear 12 Volt	-
	22-44853	2	Bulb, Clear 24 Volt	-
10	37-94803	1	Key Switch	-
11	22-40247	1	Toggle Switch, SPST maintained	-
12	22-41060	2	Diode 6 Amp 50 Volt (not shown)	-
13	22-00044	1	Fuse Holder, In-line 15 Amp 32 Volt	-
14	22-41008	1	Fuse 7- 1/2 Amp 240 VAC/DC	-
15	37-91007	1	Push Button Switch	-
16	22-44859	1	Wire Harness	-
17	16-01002	1	O-ring	-
18	22-44861	2	Bulb Diffuser, Red	-
19	12-90002	4	Self-tapping Screw	-
20	00-90043	1	Label, Panel Electrical Load Warning (not shown)	-
21	00-00013	1	Label, "12 Volt" (not shown)	-

GROUP 5 - ELECTRICAL SYSTEMS

Flybridge Panel 12 & 24 Volt

L1064D

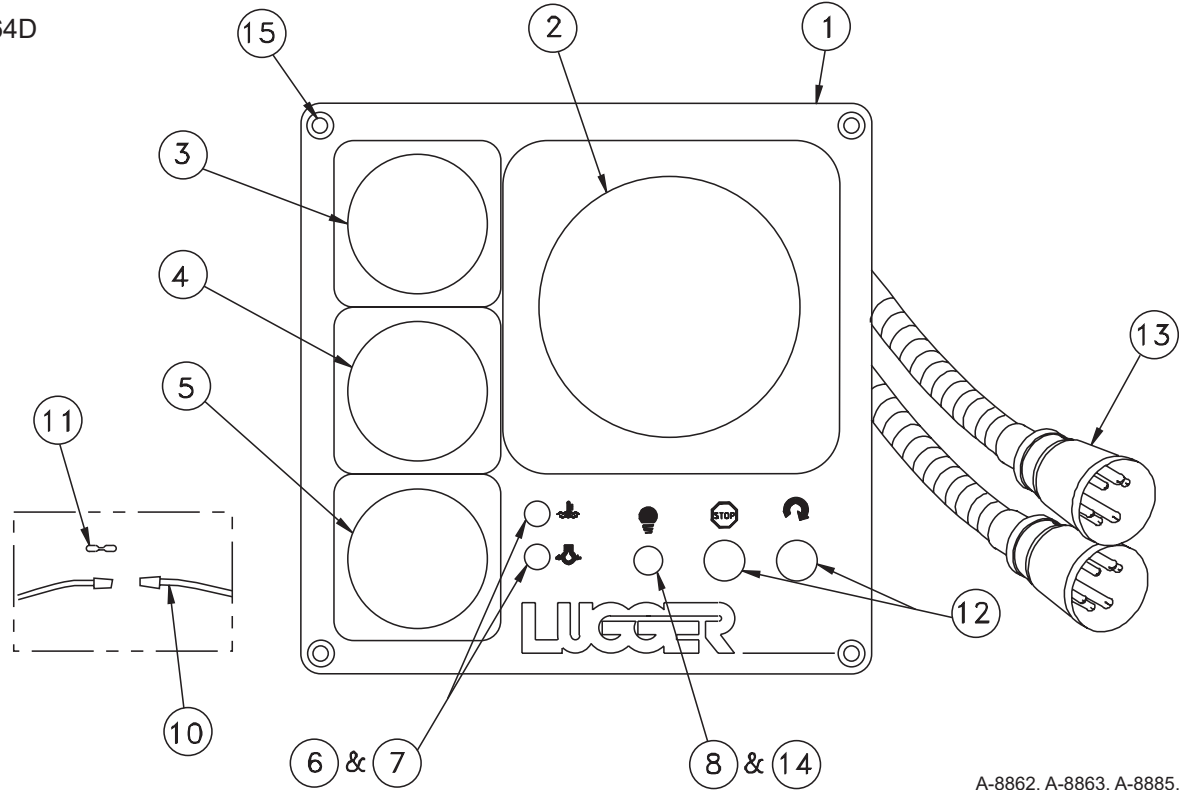

A-8862, A-8863, A-8885,
A-8886/ B-4734-3

KEY	PART NUMBER	QTY	DESCRIPTION	SERIAL NUMBER
	22-99405	1	Flybridge Panel Kit, 12 Volt (includes all keys)	-
	22-99410	1	Flybridge Panel Kit, 24 Volt (includes all keys)	-
	22-99404	1	Flybridge Panel, 12 Volt (includes all keys)	-
	22-99409	1	Flybridge Panel, 24 Volt (includes all keys)	-
1	28-96802	1	Panel Plate	-
2	37-99401	1	Tachometer 0-3000 RPM, 12 Volt	-
	37-99402	1	Tachometer 0-3000 RPM, 24 Volt	-
3	37-90033	1	Oil Pressure Gauge, 0-80 PSI, 12 Volt	-
	37-90034	1	Oil Pressure Gauge, 0-80 PSI, 24 Volt	-
4	37-90025	1	Temperature Gauge, 12 Volt	-
	37-90026	1	Temperature Gauge, 24 Volt	-
5	22-40263	1	Alarm Horn - 12/24 Volt	-
6	22-44851	2	Fault Lamp Holder, Amber	-
7	22-44852	**	Bulb, Clear - 12 Volt	-
	22-44853	**	Bulb, Clear - 24 Volt	-
8	22-40247	1	Toggle Switch (for panel lights)	-
9	22-41060	2	6 Amp 50 Volt Diode (not shown)	-
10	22-00044	1	In-Line Fuse Holder	-
11	22-41008	1	7.5 Amp Fuse	-
12	37-91007	2	Push Button Weatherproof	-
13	22-90003	2	Wire Harness	-
14	22-40361	1	Toggle Switch Boot	-
15	12-90002	4	Self Tapping Screw #8 x 1, Type AB Philips	-
16	22-41001	1	Extension Harness 10 ft. (not shown)	-
17	22-71009	1	Double Plug "Y" Harness (not shown)	-
			**As required	

Flybridge Panel 12 & 24 Volt

L1064D

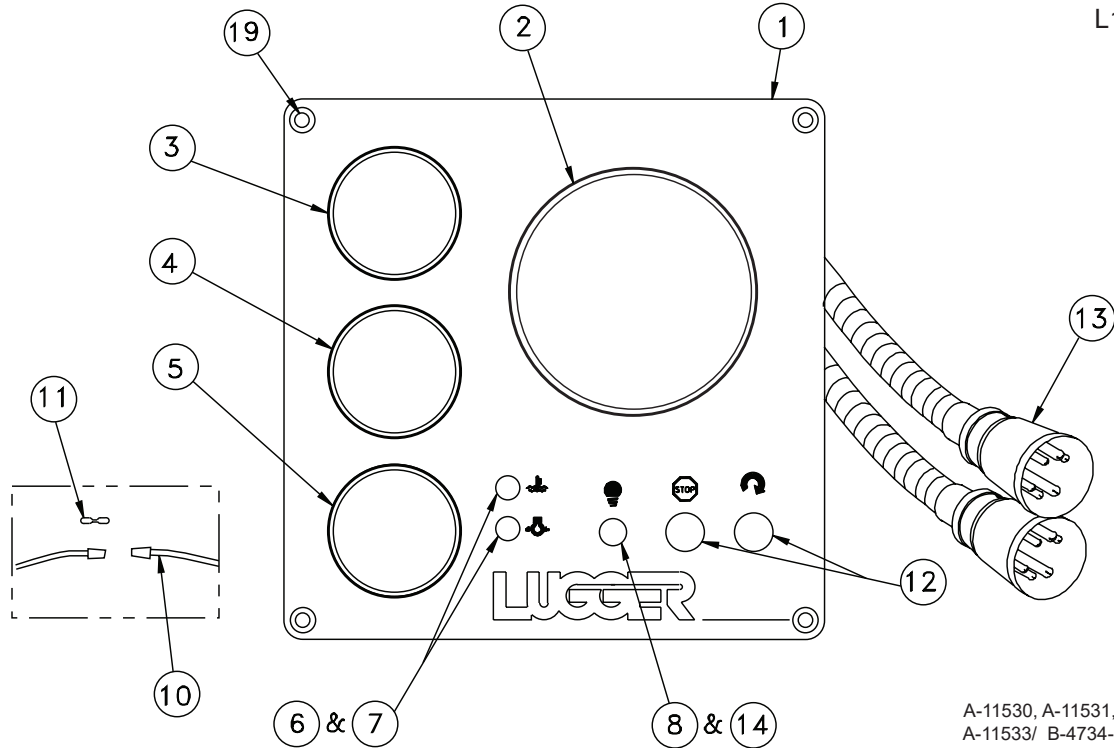

A-11530, A-11531, A-11532,
A-11533/ B-4734-3changed

KEY	PART NUMBER	QTY	DESCRIPTION	SERIAL NUMBER
••	22-99430	1	Flybridge Panel Kit, 12 Volt (includes all keys)	-
••	22-99435	1	Flybridge Panel Kit, 24 Volt (includes all keys)	-
•	22-99429	1	Flybridge Panel, 12 Volt (includes keys 1-)	-
•	22-99434	1	Flybridge Panel, 24 Volt (includes keys 1-)	-
1	28-96802	1	Panel Plate	-
2	37-90069	1	Tachometer 0-3500 RPM, 12 & 24 Volt	-
3	37-90081-1	1	Oil Pressure Gauge, 0-80 PSI, 12 Volt	-
	37-90082-1	1	Oil Pressure Gauge, 0-80 PSI, 24 Volt	-
4	37-90075-1	1	Temperature Gauge, 250°F 12 Volt	-
	37-90076-1	1	Temperature Gauge, 250°F 24 Volt	-
5	22-40263-1	1	Alarm Horn - 12/24 VDC	-
6	22-44851	2	Fault Lamp Holder, Amber	-
7	22-44852	**	Bulb, Clear - 12 Volt	-
	22-44853	**	Bulb, Clear - 24 Volt	-
8	22-40247	1	Toggle Switch (for panel lights)	-
9	22-41060	2	6 Amp 50 Volt Diode (not shown)	-
10	22-00044	1	In-Line Fuse Holder	-
11	22-41008	1	7.5 Amp Fuse	-
12	37-91007	2	Push Button Weatherproof	-
13	22-90003	1	Wire Harness	-
14	16-01002	1	O-ring	-
15	22-44861	2	Bulb Diffuser, Red (not shown)	-
16	22-40361	1	Boot, Toggle Switch (not shown)	-
17	00-90043	1	Label, Panel Electrical Load Warning (not shown)	-
18	00-00013	1	Label "12 Volt" (not shown)	-
	00-00014	1	Label "24 Volt" (not shown)	-
19	12-90002	4	Self Tapping Screw #8 x 1, Type AB Philips	-
20	22-41001	1	Extension Harness 10 ft. (not shown)	-
21	22-71009	1	Double Plug "Y" Harness (not shown)	-
			**As required	

GROUP 5 - ELECTRICAL SYSTEMS

Auxiliary Panel "Ocean Line" 12 & 24 Volt

L1064T1

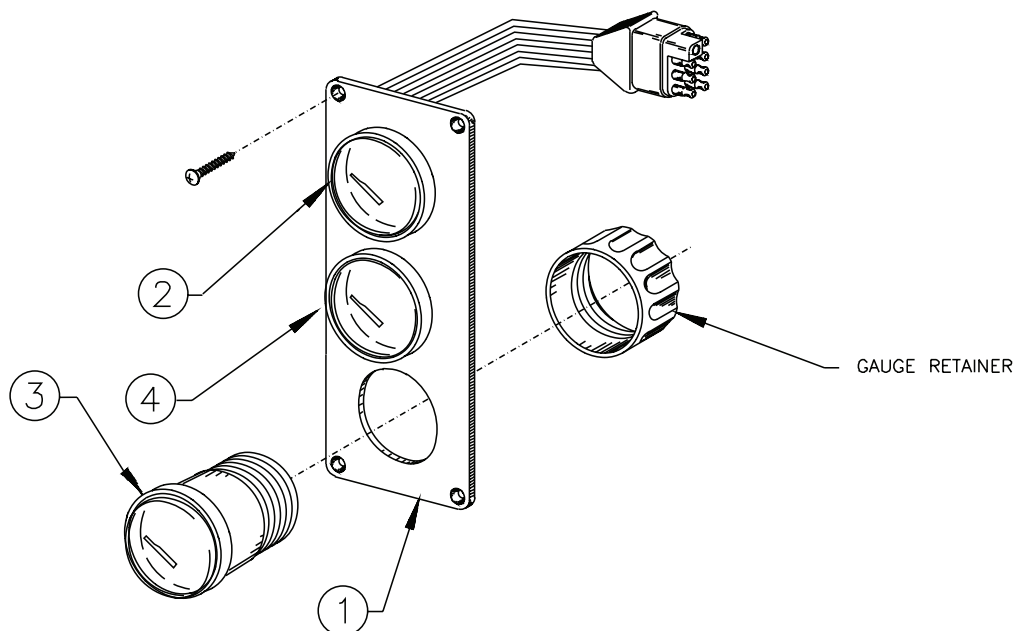

A-11546, A-11547, A-11550,
A-11551 / B-4766Cchanged

KEY	PART NUMBER	QTY	DESCRIPTION	SERIAL NUMBER
••	22-90660	1	12 Volt Auxiliary Panel Kit (includes all keys)	-
••	22-90665	1	24 Volt Auxiliary Panel Kit (includes all keys)	-
•	22-90659	1	12 Volt Auxiliary Panel (includes keys 1 - 7)	-
•	22-90664	1	24 Volt Auxiliary Panel (includes keys 1 - 7)	-
1	28-74801	1	Panel Plate	-
2	37-90029-1	1	Pyrometer Assembly (includes thermocouple & harness)	-
3	37-90083-1	1	Oil Pressure Gauge 0-400 PSI, 12 Volt	-
	37-90084-1	1	Oil Pressure Gauge 0-400 PSI, 24 Volt	-
4	37-90063-1	1	Pressure Gauge 0-28 PSI, 12 Volt	-
	37-90064-1	1	Pressure Gauge 0-28 PSI, 24 Volt	-
5	22-44865	1	Wire Harness	-
6	12-90002	4	Self Tapping Screw #8 x 1 Type AB Phillips*	-
7	37-41004	**	Bulb, Clear - 12 Volt	-
	37-41003	**	Bulb, Clear - 24 Volt	-
8	22-41094	1	Pressure Sender 0-30 PSI*	-
9	22-40239	1	Pressure Sender 400 PSI*	-
10	21-00139	**	Adapter 1/8 BSPT x 1/8 NPT*	-
11	22-94803	1	Extension Harness 3 Ft.*	-
12	21-34802	1	Connector for Thermocouple (included in #37-94809)	-
13	22-40004	1	Resistor Kit (for pyrometer, 24 Volt only)	-
			*Not shown	
			**As required	

Main Instrument Panel 12 & 24 Volt

L1064A

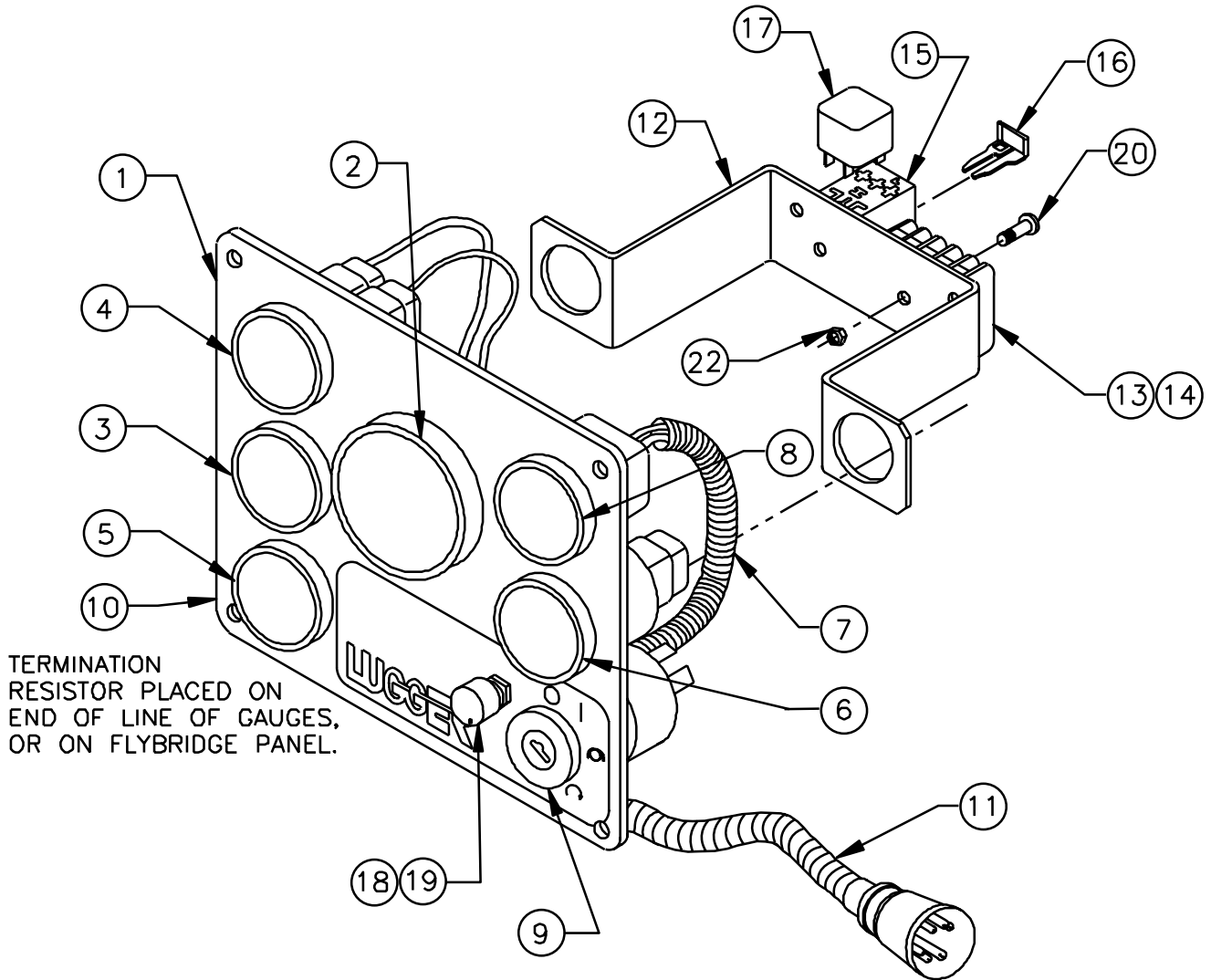

A-10523B, A-10466C/ B-8512

Main Instrument Panel 12 & 24 Volt

L1064A

KEY	PART NUMBER	QTY	DESCRIPTION	SERIAL NUMBER
••	22-99706	1	Main Instrument Panel Kit, 12 Volt (includes all keys)*	-
••	22-99701	1	Main Instrument Panel Kit, 24 Volt (includes all keys)*	-
••	22-99716	1	Main Instrument Panel Kit, 12 Volt (includes all keys)**	-
••	22-99711	1	Main Instrument Panel Kit, 24 Volt (includes all keys)**	-
1	28-90026	1	Panel Plate	-
2	37-90087	1	Tachometer, 0-3000 RPM	-
3	37-90089	1	Temperature Gauge, 250°F	-
4	37-90091	1	Pressure Gauge, 0-100 PSI	-
5	37-90093	1	Alarm Horn	-
6	37-90099	1	Voltmeter, 8-18 VDC	-
	37-90095	1	Voltmeter, 16-36 VDC	-
7	PVW-J-9	4	Jumper Assembly 9"	-
8	37-90096	1	Hourmeter	-
9	37-94803	1	Key Switch 5 Position	-
10	PVJR	1	Termination Resistor	-
11	22-99708	1	Wire Harness Assembly (22-99701 & 22-99706)	-
	22-99709	1	Wire Harness Assembly (22-99711 & 22-99716)	-
12	23-99504	1	Bracket, Terminal Strip & Relay Base	-
13	22-40498	1	Terminal Strip	-
14	22-00088	1	Number Strip	-
15	22-40391	1	Relay Base	-
16	22-40393	1	Terminal Retainer	-
17	22-42047	1	Relay, 12 VDC	-
	22-40085	1	Relay, 24 VDC	-
18	37-40024	1	Potentiometer 1k OHM 2 Watt	-
19	37-40026	1	Aluminum Knob	-
20	12-00005	2	Machine Screw, BH Slotted #8-32 x 3/4"	-
21	12-42404	1	Machine Screw, Truss Head Phillips #8-32 x 3/4" (not shown)	-
22	14-00003	3	Hex Nut, Nylock	-
23	00-00013	1	Label "12 Volt" (not shown)	-
	00-00014	1	Label "24 Volt" (not shown)	-
24	37-90086	1	Powerview Module (not shown)	-
			* Used on applications with Interconnect Harness 22-49551 and Powerview module in engine room.	
			**Used on applications with Interconnect Harness 22-49552 and Powerview module connection at Main Panel.	

Flybridge Panel 12 & 24 Volt

L1064A

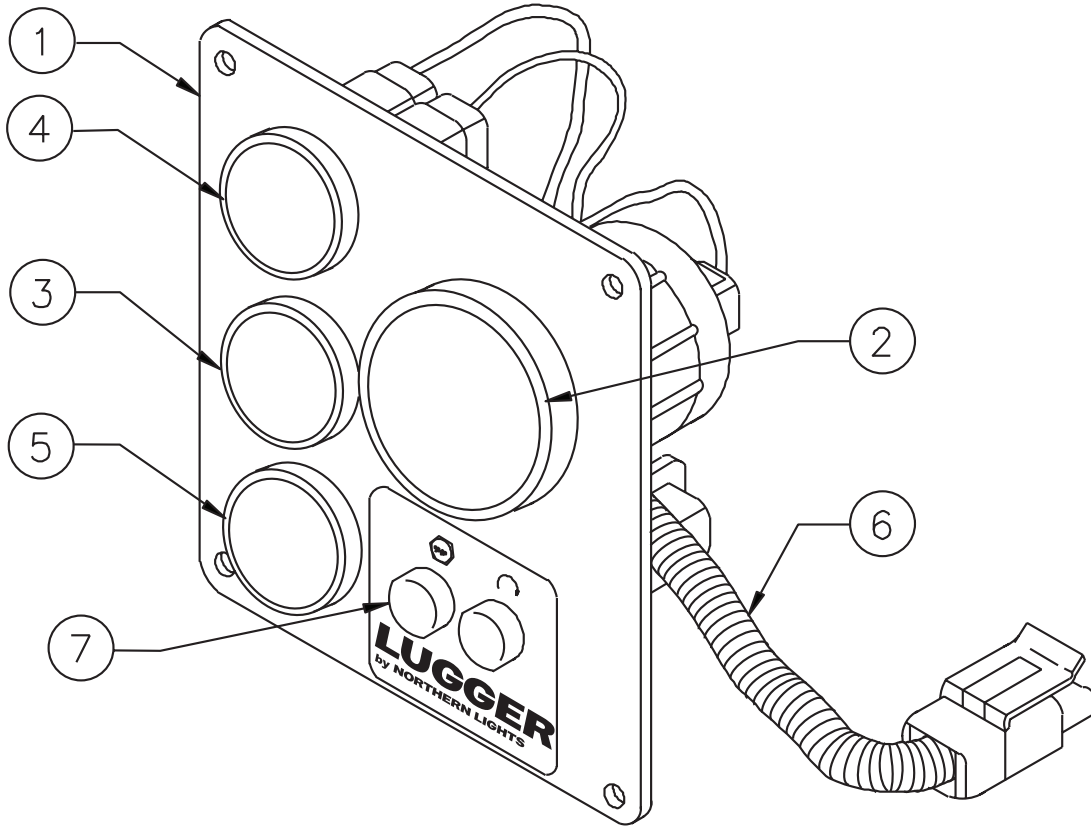

A-10467B/ B-8706

KEY	PART NUMBER	QTY	DESCRIPTION	SERIAL NUMBER
••	22-99702	1	Flybridge Panel Kit, 12 and 24 Volt (includes all keys)	-
1	28-90027	1	Panel Plate	-
2	37-90088	1	Tachometer, 0-3000 RPM	-
3	37-90090	1	Temperature Gauge, 250°F	-
4	37-90092	1	Pressure Gauge, 0-100 PSI	-
5	37-90094	1	Alarm Horn	-
6	PVW-J-9	3	Jumper Assembly 9"	-
7	37-91007	2	Switch, Push Button	-

Auxiliary Panel 12 & 24 Volt

L1064A

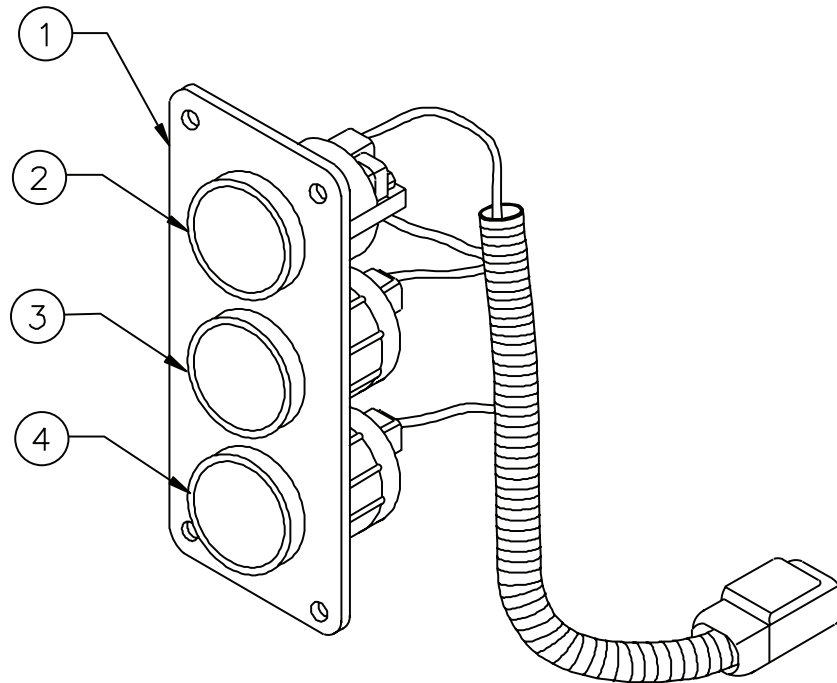

A-10524, A-10468/ B-8705

KEY	PART NUMBER	QTY	DESCRIPTION	SERIAL NUMBER
•	22-99705	1	Auxiliary Panel Kit	-
••	22-99707	1	Auxiliary Panel Kit, 12 Volt (includes all keys)	-
••	22-99703	1	Auxiliary Panel Kit, 24 Volt (includes all keys)	-
1	28-74801	1	Panel Plate	-
2	37-90016	1	Pyrometer Assembly 180°F (100°C)	-
3	37-90101	1	Oil Pressure Gauge, 0-80 PSI, 12 Volt	-
	37-90098	1	Oil Pressure Gauge, 0-80 PSI, 24 Volt	-
4	37-90100	1	Gear Pressure Gauge, 0-400 PSI, 12 Volt	-
	37-90097	1	Gear Pressure Gauge, 0-400 PSI, 24 Volt	-
5	22-40272	1	Bulb, 12 Volt	} for Pyrometer
	22-40286	1	Bulb, 24 Volt	
6	22-40325	1	Diffuser, Green 12 & 24 Volt	-
7	ES2P-80	1	Sender 80 PSI (not shown)	-
8	ES2PMK-400	1	Sender 400 PSI (not shown)	-
9	21-55201	1	Bushing 3/8 NPT x 1/8 NPT (not shown)	-

S-1 Control Panel 12 & 24 Volt

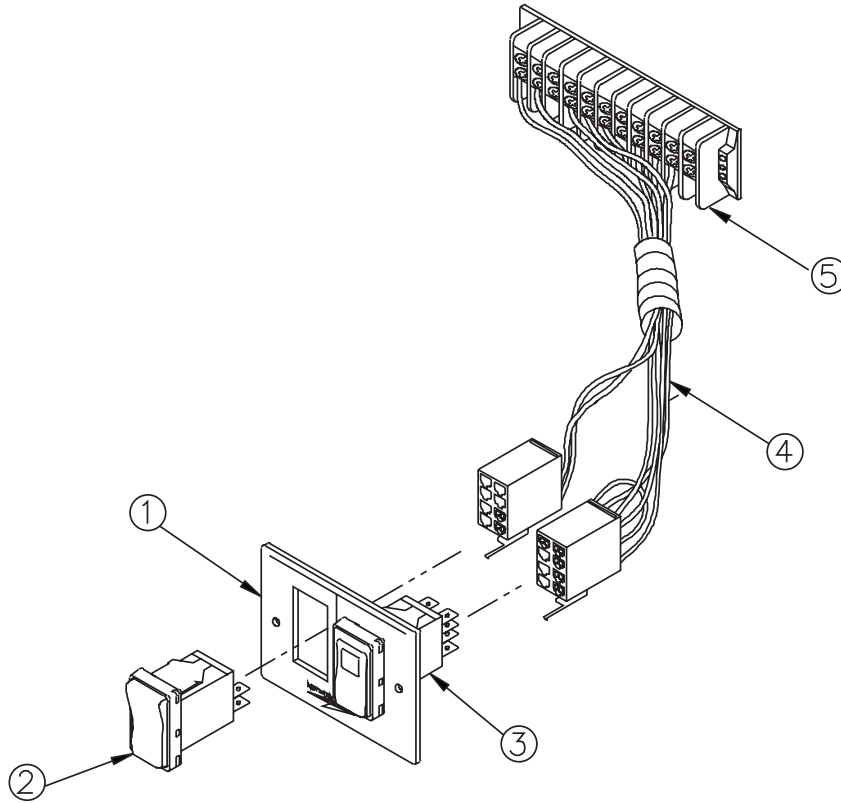

A-8555-6/ B-5970

KEY	PART NUMBER	QTY	DESCRIPTION	SERIAL NUMBER
••	22-90610	1	S-1 Control Panel Assembly, 12 Volt (includes all keys)	-
••	22-90615	1	S-1 Control Panel Assembly, 24 Volt (includes all keys)	-
1	00-40013	1	Plate, S-1 Control Panel	-
2	22-90167	1	Rocker Switch	-
3	22-90168	1	Rocker Switch	-
4	22-40388	1	Wire Harness, 12 Volt	-
	22-40389	1	Wire Harness, 24 Volt	-
5	22-41077	1	Terminal Strip	-
6	22-40012	1	Resistor, 24 Volt*	-
7	00-00013	1	Label "12 Volt" *	-
	00-00014	1	Label "24 Volt" *	-
8	22-00052	1	Number Strip, Flush Panel *	-
			*Not shown	

S-3B Control Panel 12 & 24 Volt

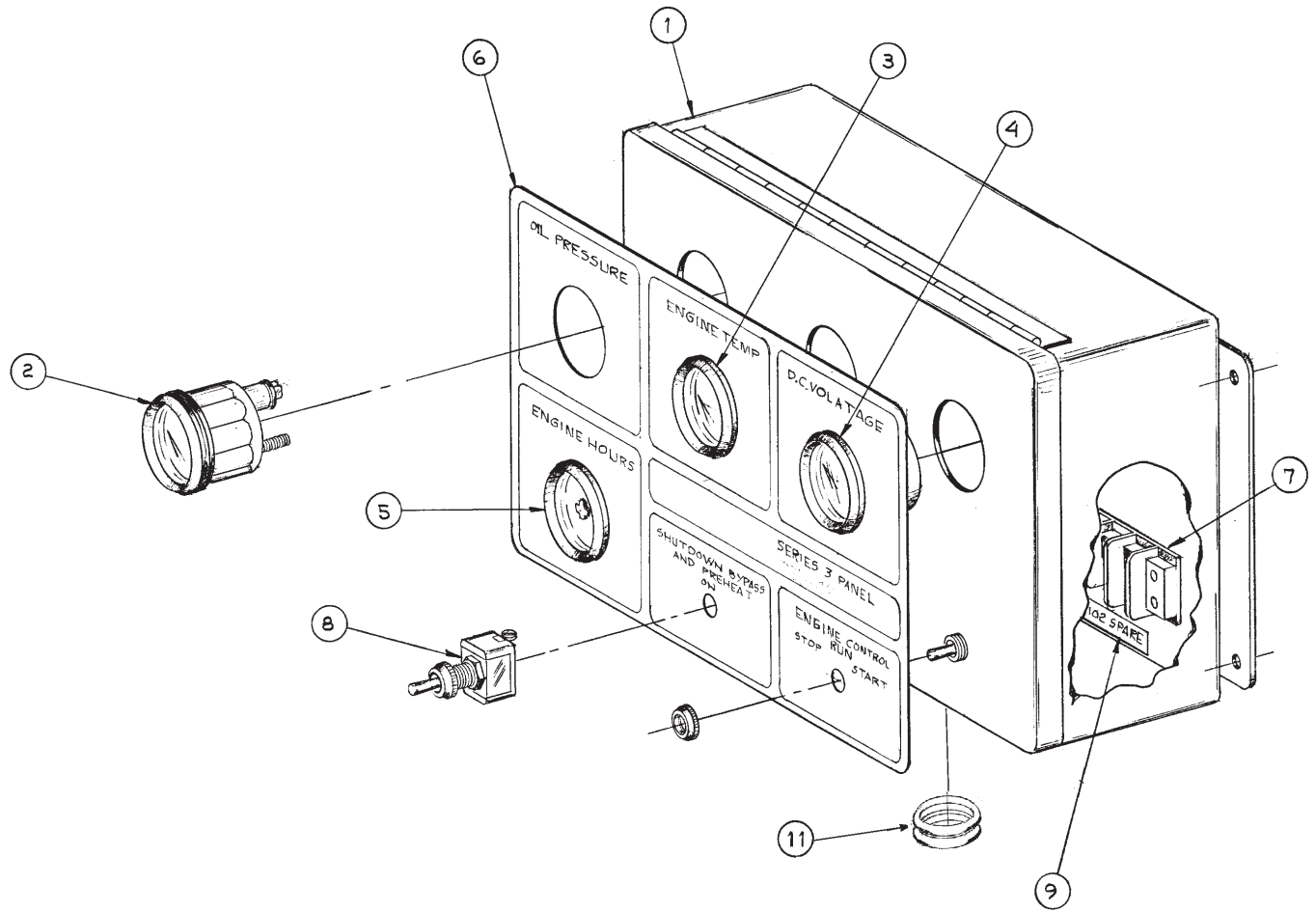

A-10525, A-10526/ C-2470

KEY	PART NUMBER	QTY	DESCRIPTION	SERIAL NUMBER
••	22-99501	1	S-3B Control Panel Assembly, 12 Volt (includes all keys)	-
••	22-99502	1	S-3B Control Panel Assembly, 24 Volt (includes all keys)	-
1	39-40008	1	Enclosure	-
2	37-90081-1	1	Oil Pressure Gauge 12 Volt	-
	37-90082-1	1	Oil Pressure Gauge 24 Volt	-
3	37-90075-1	1	Temperature Gauge 12 Volt	-
	37-90076-1	1	Temperature Gauge 24 Volt	-
4	37-90072-1	1	DC Volt Meter, 8- 16 VDC	-
	37-90073-1	1	DC Volt Meter, 18- 32 VDC	-
5	37-90074-1	1	Hour Meter	-
6	00-91018	1	Decal	-
7	22-41077	1	Terminal Board	-
8	22-41051	2	Switch	-
9	22-00052	1	Number Strip	-
10	22-40257	1	Wire Harness *	-
11	00-40028	1	Grommet	-
12	37-41004	**	Bulb, 12 Volt *	-
	37-41003	**	Bulb, 24 Volt *	-
			*Not shown	**As required

GROUP 5 - ELECTRICAL SYSTEMS

S-3C Control Panel 12 & 24 Volt

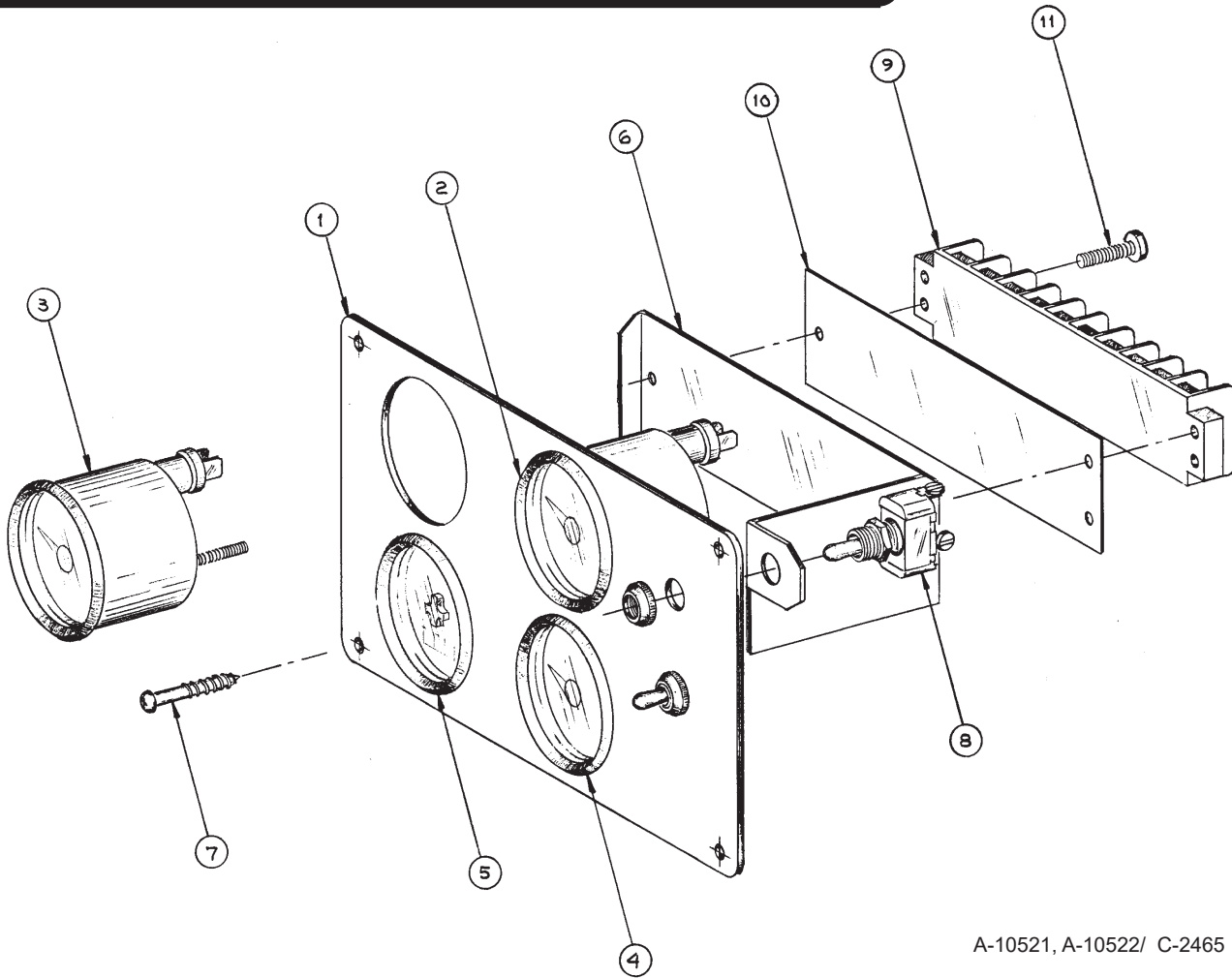

A-10521, A-10522/ C-2465

KEY	PART NUMBER	QTY	DESCRIPTION	SERIAL NUMBER
••	22-99511	1	S-3C Control Panel Assembly, 12 Volt (includes all keys)	-
••	22-99512	1	S-3C Control Panel Assembly, 24 Volt (includes all keys)	-
1	28-90010	1	Plate	-
2	37-90081-1	1	Oil Pressure Gauge, 0-80 PSI 12 Volt	-
	37-90082-1	1	Oil Pressure Gauge, 0-80 PSI 24 Volt	-
3	37-90075-1	1	Engine Temperature Gauge, 250° 12 Volt	-
	37-90076-1	1	Engine Temperature Gauge, 250° 24 Volt	-
4	37-90072-1	1	Volt Meter, 8- 16 VDC	-
	37-90073-1	1	Volt Meter, 18- 32 VDC	-
5	37-90074-1	1	Hour Meter 12/ 24 Volt	-
6	23-90014	1	Bracket	-
7	12-90007	4	Self Tapping Screw, OVH Phillips #6	-
8	22-41051	2	Switch	-
9	22-41077	1	Terminal Board	-
10	22-00052	1	Number Strip	-
11	12-00006	2	Machine Screw, #8- 32 x 1/2 "	-
12	00-00013	**	Label, 12 Volt	-
	00-00014	**	Label, 24 Volt	-
13	22-40245	1	Wire Harness*	-
14	37-41004	**	Bulb, 12 Volt*	-
	37-41003	**	Bulb, 24 Volt*	-

*Not shown

**As required

Remote 12 & 24 Volt Loud Alarm

L1064D

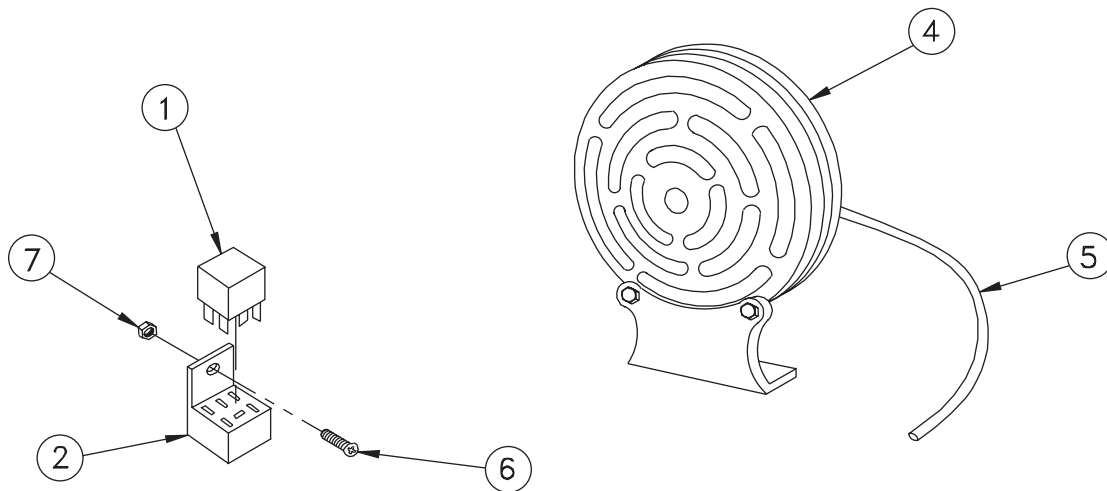

A-4186A/ PTalarm

KEY	PART NUMBER	QTY	DESCRIPTION	SERIAL NUMBER
1	22-42047	1	12 Volt Relay SPST	-
	22-40085	1	24 Volt Relay SPST	-
2	22-41032	1	Relay Base	-
3	22-41060	2	6 Amp Diode (not shown)	-
4	22-41007	1	Alarm Horn, 12 Volt	-
	22-40933	1	Alarm Horn, 24 Volt	-
5	22-74814	1	Wire Harness Assembly	-
6	12-03010	1	Machine Screw #10 - 32 x 3/8 100 F.H. CSK	-
7	14-00001	1	Hex Nut, #10 - 32	-

Belt Guard, Medium Frame Alternators without Front PTO

L- M1064D, M40C2, M1064T1, T2, M55C2, M65C2, and L- M1064A

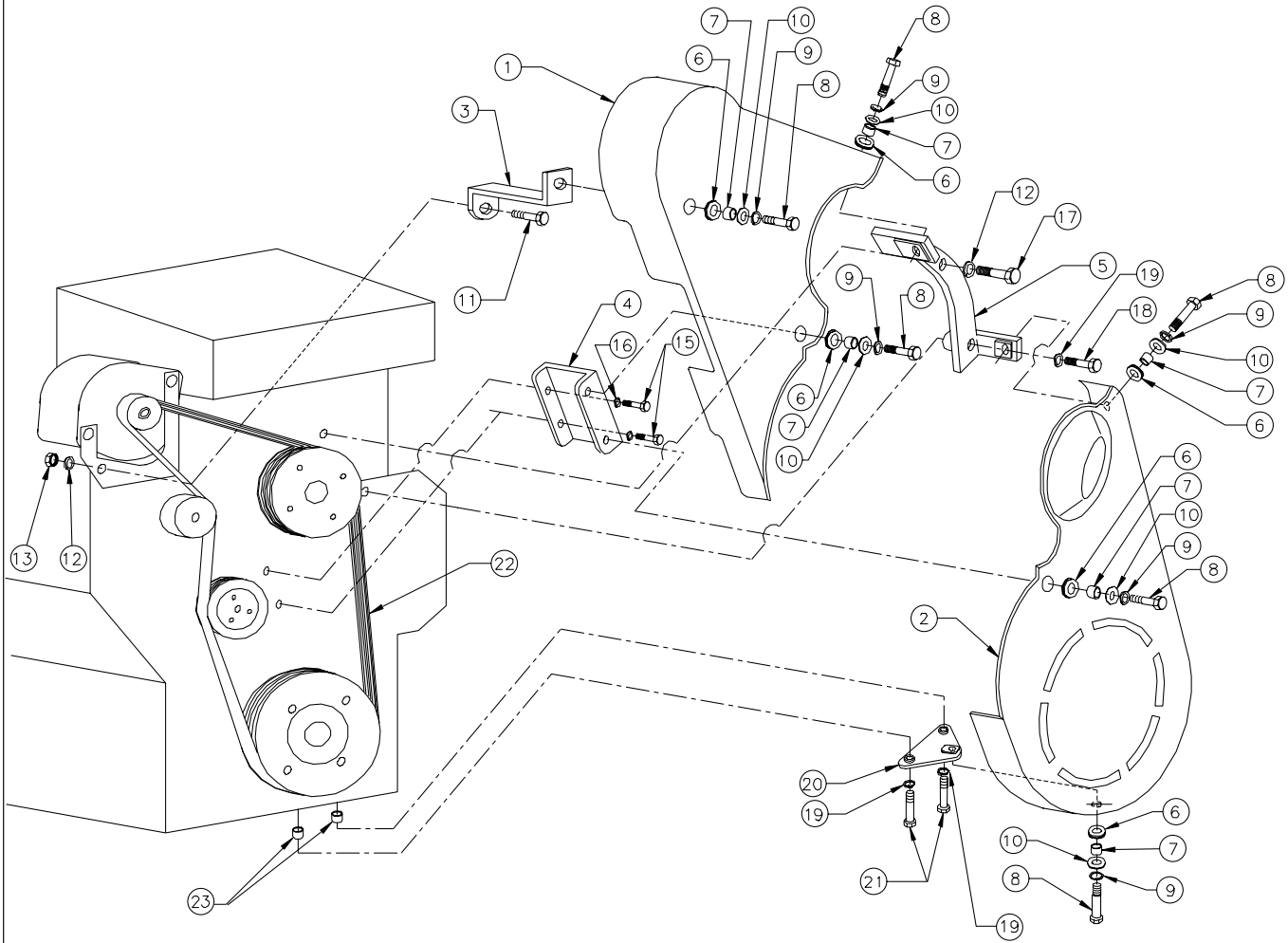

A-8534/ C-5053

Belt Guard, Medium Frame Alternators without Front PTO

L- M1064D, M40C2, M1064T1, T2, M55C2, M65C2, and L- M1064A

KEY	PART NUMBER	QTY	DESCRIPTION	SERIAL NUMBER
1	00-09501	1	Belt Guard, Upper 1/2	-
2	00-09401	1	Belt Guard, Lower 1/2	-
3	23-09502	1	Bracket	-
4	23-09503	1	Bracket	-
5	23-09507	1	Bracket	-
6	00-00017	6	Grommet	-
7	21-05002	6	Spacer	-
8	12-09712	6	Capscrew, Hex Head M8 x 1.25 x 25 mm S/S	-
9	15-00705	6	Lock Washer M8 S/S	-
10	15-70004	6	Snubbing Washer S/S	-
11	12-00832	1	Capscrew, Hex Head M10 x 1.5 x 30 mm	-
12	15-00802	2	Lock Washer M10	-
13	14-00811	1	Hex Nut M10 x 1.5	-
15	12-00072	2	Capscrew, Socket Head M6 x 1.0 x 30 mm	-
16	15-00018	2	Lock Washer, Hi-collar 1/4	-
17	12-00805	1	Capscrew, Hex Head M10 x 1.5 x 20 mm	-
18	12-00717	1	Capscrew, Hex Head M8 x 1.25 x 60 mm	-
19	15-00702	3	Lock Washer M8	-
20	23-09506	1	Bracket	-
21	12-00714	2	Capscrew, Hex Head M8 x 1.25 x 40 mm	-
22		1	Drive Belt, Poly-V (see application chart)	-
23	21-05002	**	Spacer	-

**As required

GROUP 5 - ELECTRICAL SYSTEMS

Belt Guard, Medium Frame Alternators without Front PTO

M1064T2CMA

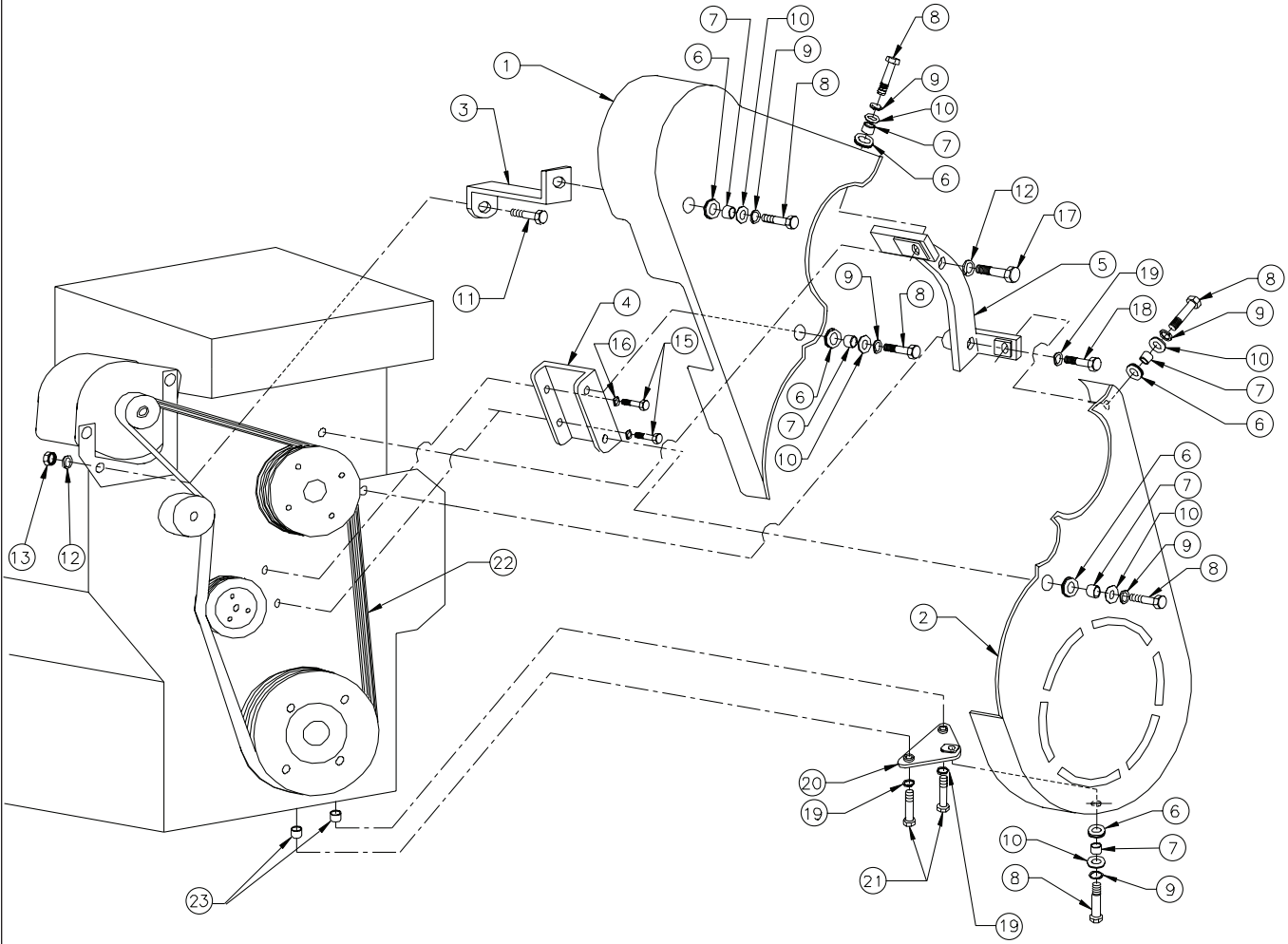

C-5053_mod

Belt Guard, Medium Frame Alternators without Front PTO

M1064T2MCA

KEY	PART NUMBER	QTY	DESCRIPTION	SERIAL NUMBER
1	00-09613	1	Belt Guard, Upper 1/2	-
2	00-09402	1	Belt Guard, Lower 1/2	-
3	23-09502	1	Bracket	-
4	23-09503	1	Bracket	-
5	23-09507	1	Bracket	-
6	00-00017	6	Grommet	-
7	21-05002	6	Spacer	-
8	12-09712	6	Capscrew, Hex Head M8 x 1.25 x 25 mm S/S	-
9	15-00705	6	Lock Washer M8 S/S	-
10	15-70004	6	Snubbing Washer S/S	-
11	12-00832	1	Capscrew, Hex Head M10 x 1.5 x 30 mm	-
12	15-00802	2	Lock Washer M10	-
13	14-00811	1	Hex Nut M10 x 1.5	-
15	12-00072	2	Capscrew, Socket Head M6 x 1.0 x 30 mm	-
16	15-00018	2	Lock Washer, Hi-collar 1/4	-
17	12-00805	1	Capscrew, Hex Head M10 x 1.5 x 20 mm	-
18	12-00717	1	Capscrew, Hex Head M8 x 1.25 x 60 mm	-
19	15-00702	3	Lock Washer M8	-
20	23-09506	1	Bracket	-
21	12-00714	2	Capscrew, Hex Head M8 x 1.25 x 40 mm	-
22	R123438	1	Drive Belt, Poly-V	-
23	21-05002	**	Spacer	-
			**As required	

Belt Guard, Large Frame Alternators without Front PTO

L- M1064D, M40C2, M1064T1,T2, M55C2, M65C2, and L- M1064A

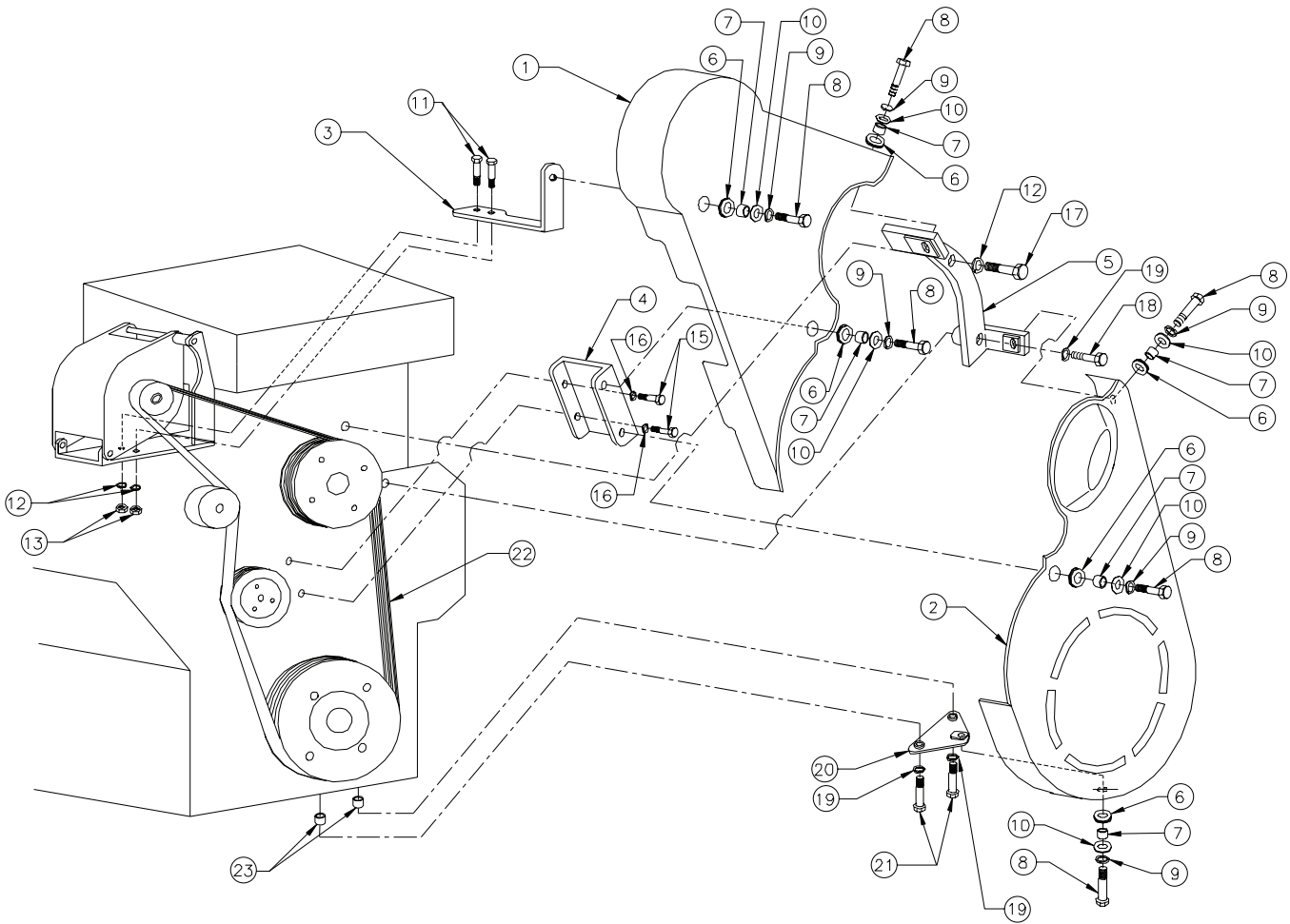

A-8691/ C-5056

Belt Guard, Large Frame Alternators without Front PTO

L- M1064D, M40C2, M1064T1,T2, M55C2, M65C2, and L- M1064A

KEY	PART NUMBER	QTY	DESCRIPTION	SERIAL NUMBER
1	00-09503	1	Belt Guard, Upper 1/2	-
2	00-09401	1	Belt Guard, Lower 1/2	-
3	23-09508	1	Bracket	-
4	23-09503	1	Bracket	-
5	23-09507	1	Bracket	-
6	00-00017	6	Grommet	-
7	21-05002	6	Spacer	-
8	12-09712	6	Capscrew, Hex Head M8 x 1.25 x 25 mm S/S	-
9	15-00705	6	Lock Washer M8 S/S	-
10	15-70004	6	Snubbing Washer S/S	-
11	12-00814	2	Capscrew, Hex Head M10 x 1.5 x 35 mm	-
12	15-00802	3	Lock Washer M10	-
13	14-00811	3	Hex Nut M10 x 1.5	-
15	12-00072	1	Capscrew, Socket Head M6 x 1.0 x 30 mm	-
16	15-00018	2	Lock Washer, Hi-collar 1/4	-
17	12-00805	1	Capscrew, Hex Head M10 x 1.5 x 20 mm	-
18	12-00717	1	Capscrew, Hex Head M8 x 1.25 x 60 mm	-
19	15-00702	3	Lock Washer M8	-
20	23-09506	1	Bracket	-
21	12-00714	2	Capscrew, Hex Head M8 x 1.25 x 40 mm	-
22		1	Drive Belt, Poly-V (see application chart)	-
23	21-05002	**	Spacer	-
			**As required	

Belt Guard, Medium Frame Alternators without Front PTO

M1064H

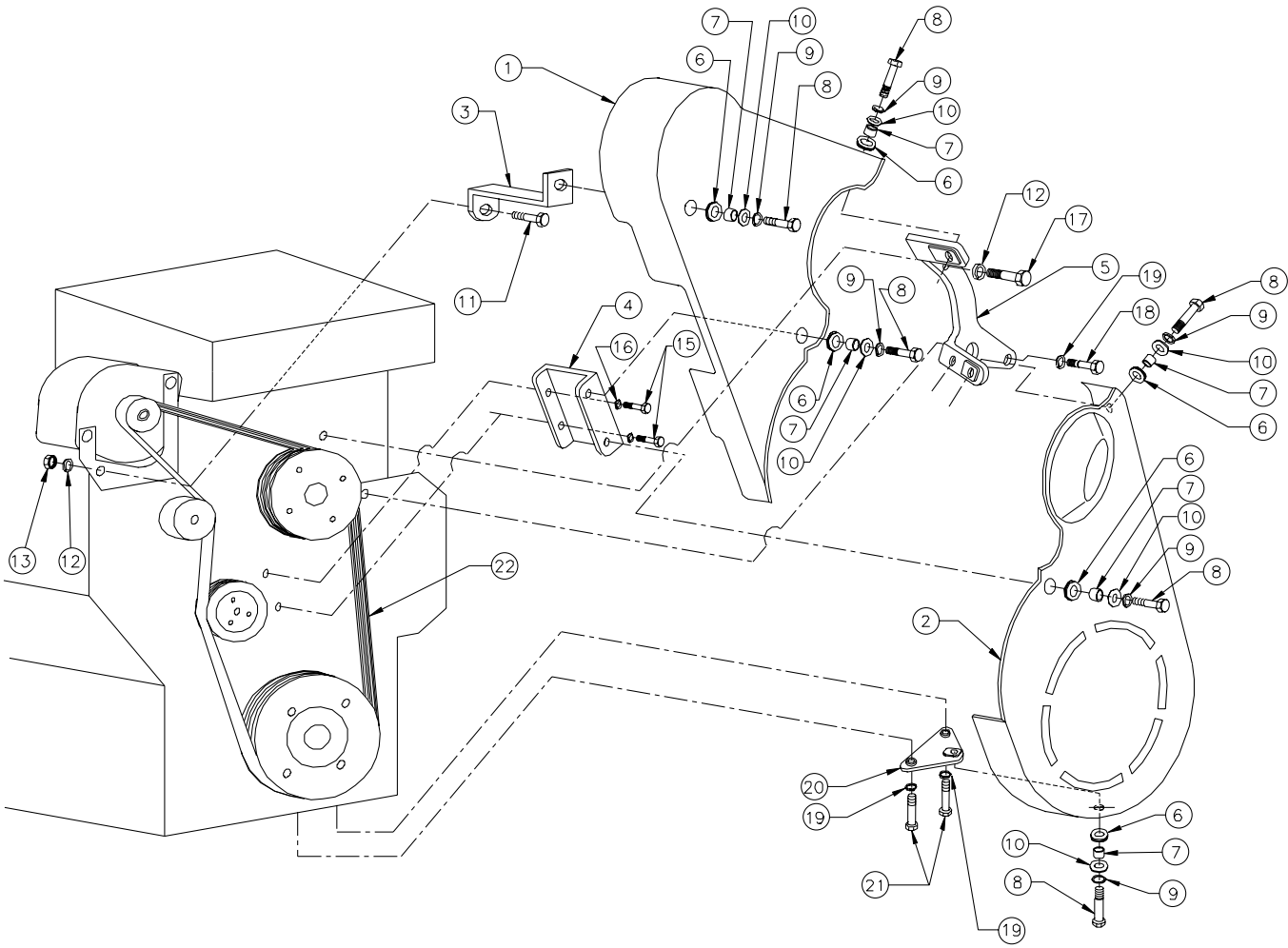

A-8534/ C-5053

Belt Guard, Medium Frame Alternators without Front PTO

M1064H

KEY	PART NUMBER	QTY	DESCRIPTION	SERIAL NUMBER
1	00-09509	1	Belt Guard, Upper 1/2	-
2	00-09401	1	Belt Guard, Lower 1/2	-
3	23-09513	1	Bracket	-
4	23-09503	1	Bracket	-
5	23-09512	1	Bracket	-
6	00-00017	6	Grommet	-
7	21-05002	6	Spacer	-
8	12-09712	6	Capscrew, Hex Head M8 x 1.25 x 25 mm S/S	-
9	15-00705	6	Lock Washer M8 S/S	-
10	15-70004	6	Snubbing Washer S/S	-
11	12-00832	1	Capscrew, Hex Head M10 x 1.5 x 30 mm	-
12	15-00802	2	Lock Washer M10	-
13	14-00811	1	Hex Nut M10 x 1.5	-
15	12-00072	2	Capscrew, Socket Head M6 x 1.0 x 30 mm	-
16	15-00018	2	Lock Washer, Hi-collar 1/4	-
17	12-00805	1	Capscrew, Hex Head M10 x 1.5 x 20 mm	-
18	12-00717	1	Capscrew, Hex Head M8 x 1.25 x 60 mm	-
19	15-00702	3	Lock Washer M8	-
20	23-09506	1	Bracket	-
21	12-00714	2	Capscrew, Hex Head M8 x 1.25 x 40 mm	-
22		1	Drive Belt, Poly-V (see application chart)	-

Belt Guard, Large Frame Alternators without Front PTO

M1064H

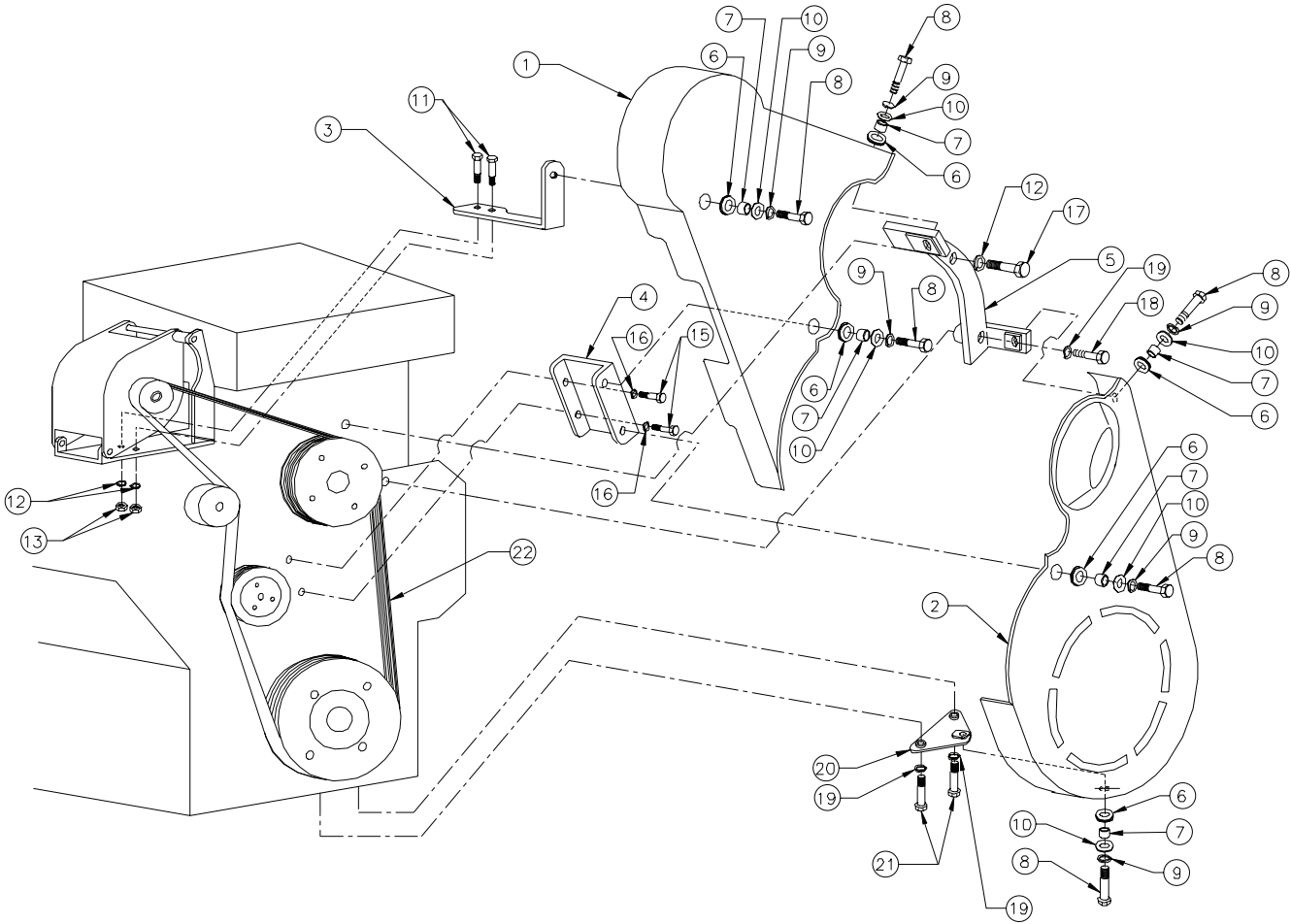

A-8691/ C-5056

Belt Guard, Large Frame Alternators without Front PTO

M1064H

KEY	PART NUMBER	QTY	DESCRIPTION	SERIAL NUMBER
1	00-09503	1	Belt Guard, Upper 1/2	-
2	00-09401	1	Belt Guard, Lower 1/2	-
3	23-09508	1	Bracket	-
4	23-09503	1	Bracket	-
5	23-09507	1	Bracket	-
6	00-00017	6	Grommet	-
7	21-05002	6	Spacer	-
8	12-09712	6	Capscrew, Hex Head M8 x 1.25 x 25 mm S/S	-
9	15-00705	6	Lock Washer M8 S/S	-
10	15-70004	6	Snubbing Washer S/S	-
11	12-00814	2	Capscrew, Hex Head M10 x 1.5 x 35 mm	-
12	15-00802	3	Lock Washer M10	-
13	14-00811	3	Hex Nut M10 x 1.5	-
15	12-00072	1	Capscrew, Socket Head M6 x 1.0 x 30 mm	-
16	15-00018	2	Lock Washer, Hi-collar 1/4	-
17	12-00805	1	Capscrew, Hex Head M10 x 1.5 x 20 mm	-
18	12-00717	1	Capscrew, Hex Head M8 x 1.25 x 60 mm	-
19	15-00702	3	Lock Washer M8	-
20	23-09506	1	Bracket	-
21	12-00714	2	Capscrew, Hex Head M8 x 1.25 x 40 mm	-
22		1	Drive Belt, Poly-V (see application chart)	-

Belt Guard, Medium Frame Alternators with PTO

L- M1064D, M40C2, M1064T1, T2, M55C2, M65C2, and L- M1064A

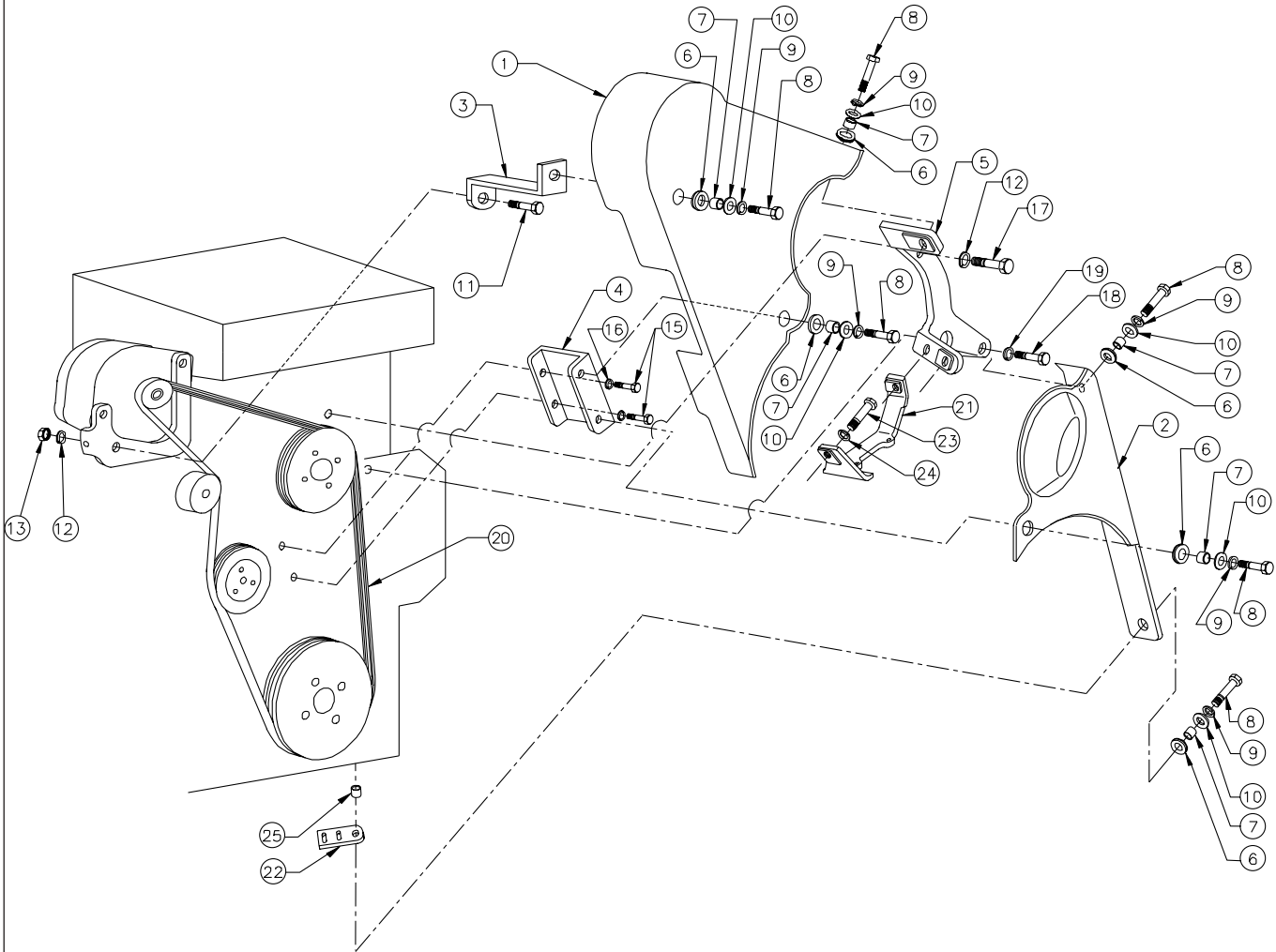

A-10996/ C-5736

Belt Guard, Medium Frame Alternators with PTO

L- M1064D, M40C2, M1064T1, T2, M55C2, M65C2, and L- M1064A

KEY	PART NUMBER	QTY	DESCRIPTION	SERIAL NUMBER
1	00-09501	1	Belt Guard, Upper 1/2, Medium Frame Alternator	-
2	00-09502	1	Belt Guard, Lower 1/2	-
3	23-09502	1	Bracket, Medium Frame Alternator	-
4	23-09503	1	Bracket	-
5	23-09507	1	Bracket	-
6	00-00017	6	Grommet	-
7	21-05002	6	Spacer	-
8	12-09712	6	Capscrew, Hex Head M8 x 1.25 x 25 mm S/S	-
9	15-00705	6	Lock Washer M8 S/S	-
10	15-70004	6	Snubbing Washer S/S	-
11	12-00832	2	Capscrew, Hex Head M10 x 1.5 x 30 mm	-
12	15-00802	2	Lock Washer M10	-
13	14-00811	3	Hex Nut M10 x 1.5	-
15	12-00072	2	Capscrew, Socket Head M6 x 1.0 x 30 mm	-
16	15-00018	2	Lock Washer, Hi-collar 1/4	-
17	12-00805	1	Capscrew, Hex Head M10 x 1.5 x 20 mm	-
18	12-00717	1	Capscrew, Hex Head M8 x 1.25 x 60 mm	-
19	15-00702	1	Lock Washer M8	-
20		1	Drive Belt, Poly-V (see application chart)	-
21	23-09510	1	Bracket, Extra Drive Belt Support	-
22	23-09511	2	Bracket, Extra Drive Belt Support	-
23	12-00751	2	Capscrew, Hex Head M8 x 1.25 x 16 mm	-
24	15-00702	2	Lock Washer M8	-
25	21-05002	**	Spacer	-
			**As required	

Belt Guard, Large Frame Alternators with PTO

L- M1064D , M40C2, M1064T1, T2, M55C2, M65C2, and L- M1064A

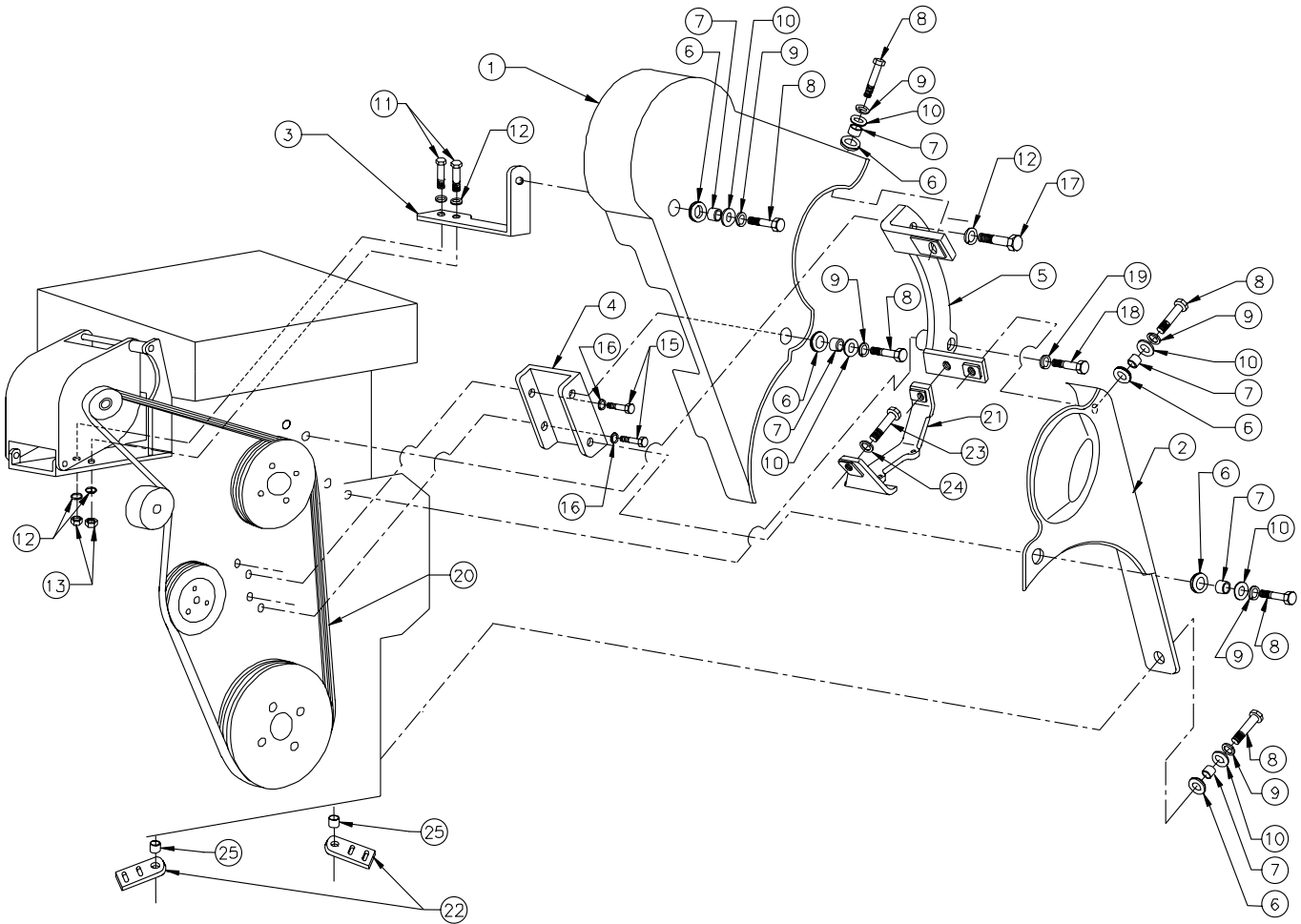

A-8692A, A-8696A/ C-5735

Belt Guard, Large Frame Alternators with PTO

L- M1064D, M40C2, M1064T1, T2, M55C2, M65C2, and L- M1064A

KEY	PART NUMBER	QTY	DESCRIPTION	SERIAL NUMBER
1	00-09503	1	Belt Guard, Upper 1/2	-
2	00-09502	1	Belt Guard, Lower 1/2	-
3	23-09508	1	Bracket	-
4	23-09503	1	Bracket	-
5	23-09507	1	Bracket	-
6	00-00017	6	Grommet	-
7	21-05002	6	Spacer	-
8	12-09712	6	Capscrew, Hex Head M8 x 1.25 x 25 mm S/S	-
9	15-00705	6	Lock Washer M8 S/S	-
10	15-70004	6	Snubbing Washer S/S	-
11	12-00814	2	Capscrew, Hex Head M10 x 1.5 x 35 mm	-
12	15-00802	3	Lock Washer M10	-
13	14-00811	3	Hex Nut M10 x 1.5	-
15	12-00072	1	Capscrew, Socket Head M6 x 1.0 x 30 mm	-
16	15-00018	2	Lock Washer, Hi-collar 1/4	-
17	12-00805	1	Capscrew, Hex Head M10 x 1.5 x 20 mm	-
18	12-00717	1	Capscrew, Hex Head M8 x 1.25 x 60 mm	-
19	15-00702	3	Lock Washer M8	-
20		2	Drive Belt, Poly-V, L-M1064D, M40C2 (see application chart)	-
21	23-09510	1	Bracket, Extra Drive Belt Support	-
22	23-09511	2	Bracket, Extra Drive Belt Support	-
23	12-00751	2	Capscrew, Hex Head M8 x 1.25 x 16 mm	-
24	15-00702	2	Lock Washer, M8	-
25	21-05002	**	Spacer	-
			**As required	

Belt Guard, Medium Frame Alternators with PTO

M1064H

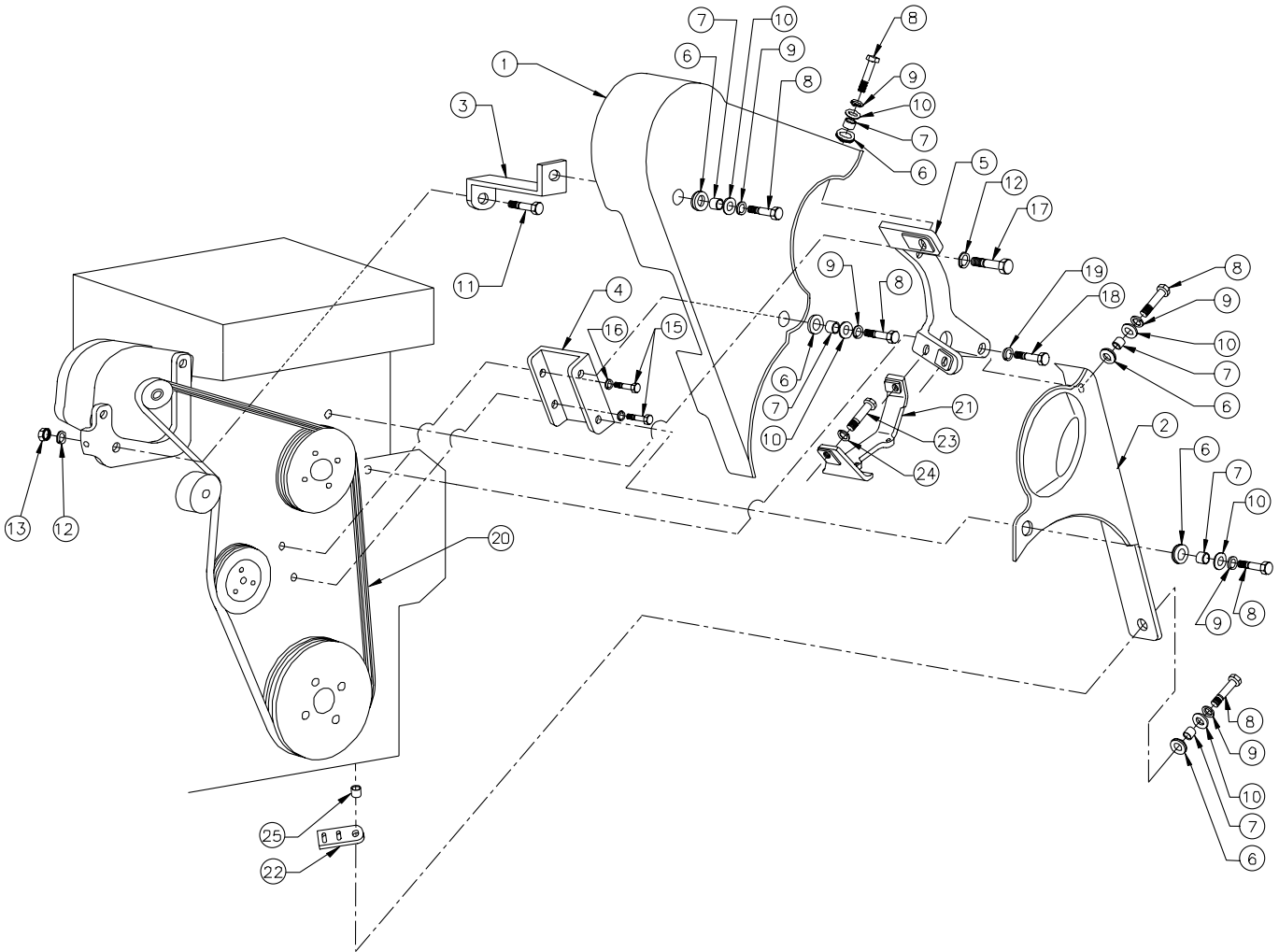

A-10996/ C-5736

Belt Guard, Medium Frame Alternators with PTO

M1064H

KEY	PART NUMBER	QTY	DESCRIPTION	SERIAL NUMBER
1	00-09509	1	Belt Guard, Upper 1/2	-
2	00-09502	1	Belt Guard, Lower 1/2	-
3	23-09513	1	Bracket	-
4	23-09503	1	Bracket	-
5	23-09512	1	Bracket	-
6	00-00017	6	Grommet	-
7	21-05002	6	Spacer	-
8	12-09712	6	Capscrew, Hex Head M8 x 1.25 x 25 mm S/S	-
9	15-00705	6	Lock Washer M8 S/S	-
10	15-70004	6	Snubbing Washer S/S	-
11	12-00832	2	Capscrew, Hex Head M10 x 1.5 x 30 mm	-
12	15-00802	2	Lock Washer M10	-
13	14-00811	3	Hex Nut M10 x 1.5	-
15	12-00072	2	Capscrew, Socket Head M6 x 1.0 x 30 mm	-
16	15-00018	2	Lock Washer, Hi-collar 1/4	-
17	12-00805	1	Capscrew, Hex Head M10 x 1.5 x 20 mm	-
18	12-00717	1	Capscrew, Hex Head M8 x 1.25 x 60 mm	-
19	15-00702	1	Lock Washer M8	-
20		2	Drive Belt, Poly-V (see application chart)	-
21	23-09510	1	Bracket, Extra Drive Belt Support	-
22	23-09511	2	Bracket, Extra Drive Belt Support	-
23	12-00751	2	Capscrew, Hex Head M8 x 1.25 x 16 mm	-
24	15-00702	2	Lock Washer M8	-

Belt Guard, Large Frame Alternators with PTO

M1064H

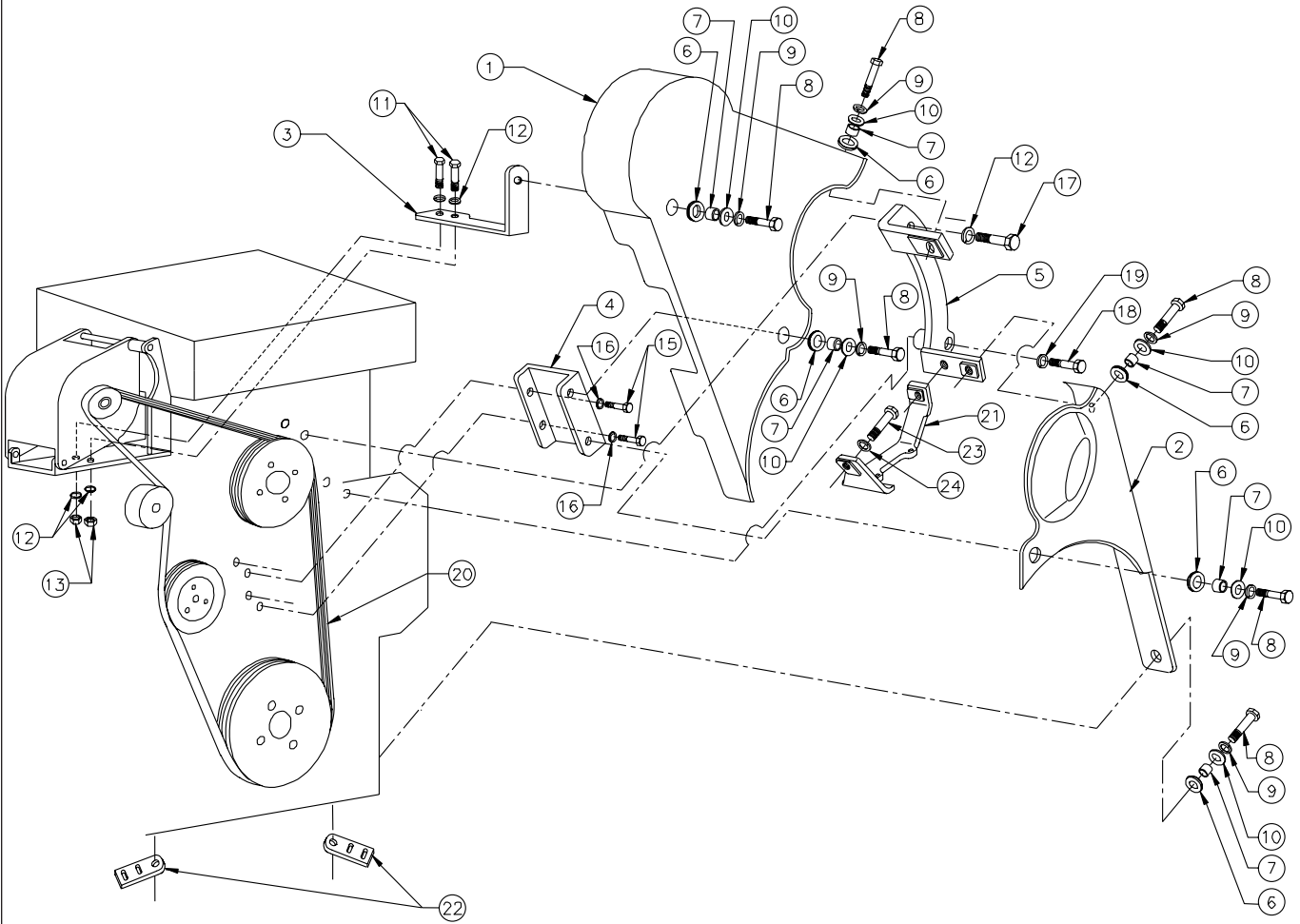

A-8692A, A-8696A/ C-5735

Belt Guard, Large Frame Alternators with PTO

M1064H

KEY	PART NUMBER	QTY	DESCRIPTION	SERIAL NUMBER
1	00-09503	1	Belt Guard, Upper 1/2	-
2	00-09502	1	Belt Guard, Lower 1/2	-
3	23-09508	1	Bracket	-
4	23-09503	1	Bracket	-
5	23-09512	1	Bracket	-
6	00-00017	6	Grommet	-
7	21-05002	6	Spacer	-
8	12-09712	6	Capscrew, Hex Head M8 x 1.25 x 25 mm S/S	-
9	15-00705	6	Lock Washer M8 S/S	-
10	15-70004	6	Snubbing Washer S/S	-
11	12-00814	2	Capscrew, Hex Head M10 x 1.5 x 35 mm	-
12	15-00802	3	Lock Washer M10	-
13	14-00811	3	Hex Nut M10 x 1.5	-
15	12-00072	1	Capscrew, Socket Head M6 x 1.0 x 30 mm	-
16	15-00018	2	Lock Washer, Hi-collar 1/4	-
17	12-00805	1	Capscrew, Hex Head M10 x 1.5 x 20 mm	-
18	12-00717	1	Capscrew, Hex Head M8 x 1.25 x 60 mm	-
19	15-00702	3	Lock Washer M8	-
20		2	Drive Belt, Poly-V (see application chart)	-
21	23-09510	1	Bracket, Extra Drive Belt Support	-
22	23-09511	2	Bracket, Extra Drive Belt Support	-
23	12-00751	2	Capscrew, Hex Head M8 x 1.25 x 16 mm	-
24	15-00702	2	Lock Washer, M8	-

GROUP 6 - GASKETS

Gasket Set, Engine Overhaul

KEY	PART NUMBER	QTY	DESCRIPTION	SERIAL NUMBER
			L- M1064D, M40C2, M1064T1, T2, M55C2, M65C2 Engine Gasket Set	
••	29-09400	1	Gasket Set (includes all keys)	
1	R123542	1	Gasket, Rocker Arm Cover	-
2	R521439	4	Gasket, Exhaust Manifold	-
3	R135896	1	Gasket, Thermostat Cover	-
4	R123226	2	Gasket, Water By-pass Tube	-
5	R123345	1	Gasket, Thermostat Housing	-
6	R123570	1	Gasket, Turbocharger Oil Outlet Tube	-
7	R123575	4	O-ring, Rocker Arm Cover Hold Down Stud	-
8	R116515	1	Engine Cylinder Head Gasket	-
9	R501373	1	Gasket, Thermostat Cover	-
11	R92097	1	Gasket, Turbocharger to Exhaust Manifold	-
12	RE527042	1	Gasket, Engine Major Overhaul	-
	TY6304	1	Sealant	-
13	R123352	1	Gasket, Oil Pan	-
14	R75892	1	O-ring, Oil Pump Tube Connector	-
15	R97185	1	O-ring, Oil Pump Outlet Tube to Cover	-
16	R61871	1	O-ring, Oil Pump Intake Tube	-
17	A4827R	1	Washer	-
18	RE44574	1	Seal, Rear Oil	-
19	RE59810	1	Seal Kit, Front Oil Seal	-
20	R123273	1	O-ring, Fuel Transfer Pump	-
21	R123417	1	Gasket, Water Pump	-
22	R136516	1	Gasket, Timing Gear Cover	-
	R136515	1	Gasket, Timing Gear Cover	-
23	R123501	1	Gasket, Oil Cooler Housing	-
24	R502864	1	Gasket, Remote Oil Filter Adapter	-
25	R123525	1	Gasket, Oil Filter Header	-
26	R53108	1	Gasket, Starting Motor	-
27	R72328	4	O-ring, Oil Filter Tubes	-
28	R89944	1	O-ring, Water Pump Inlet	-
29	R61105	2	O-ring, Connector Tube to Timing Gear Cover	-
30	T122075	2	O-ring, Oil Cooler to Housing	-
31	R501428	1	Gasket, Coolant Passage Adapter	-
32	R500374	1	Gasket, Oil Filter Header	-
33	RE526670	1	Gasket Kit, Cylinder Head Removal	-
34	RE526671	1	Gasket Kit, in Chassis Overhaul	-
35	R123353	1	Gasket, Engine Oil Pan	-
36	RE527042	1	Gasket Kit	-
	RE526671	1	Gasket Kit	-
37	16-15005	4	O-ring	-
38	16-01000	2	O-ring	-
39	16-31001	1	O-ring	-
40	052300400	1	O-ring	-
41	11-31011	4	Gasket, Exhaust	-
42	11-30013	1	Gasket, Exhaust Flange	-
43	11-31401	1	Gasket, K26 Turbo Mounting	-
44	11-21011	2	Gasket, Intake Port	-
45	11-31031	1	Gasket, Turbo Oil Return	-
46	11-31012	1	Gasket	-
47	11-11022	1	Gasket, Filler Neck Mtg.	-
48	11-11023	1	Gasket, Manifold to Expansion Tank	-
49	11-10015	2	Thermostat Seal Ring	-

Gasket Set, Engine Overhaul

KEY	PART NUMBER	QTY	DESCRIPTION	SERIAL NUMBER
			L- M1064D, M40C2, M1064T1, T2, M55C2, M65C2 Engine Gasket Set (continued)	
50	11-11013	1	Gasket, Thermostat Cover Mtg.	-
51	11-11043	1	Gasket, Expansion Tank Connection	-
52	16-19502	1	O-ring	-
53	16-14804	1	O-ring	-
54	16-19503	1	O-ring	-
55	16-19501	2	O-ring	-
56	15-09501	2	Sealing Washer, Copper M22	-
57	11-31615	1	Gasket, Turbo/ Exhaust Mtg.	-
			L- M1064A Engine Gasket Set	
••	29-09401	1	Gasket Set (includes all keys)	-
1	R123542	1	Gasket, Rocker Arm Cover	-
2	R521439	4	Gasket, Exhaust Manifold	-
3	R135896	1	Gasket, Thermostat Cover	-
4	R123226	2	Gasket, Water By-pass Tube	-
5	R123345	1	Gasket, Thermostat Housing	-
6	R123570	1	Gasket, Turbocharger Oil Outlet Tube	-
7	R123575	4	O-ring, Rocker Arm Cover Hold Down Stud	-
8	R116515	1	Engine Cylinder Head Gasket	-
9	R501373	1	Gasket, Thermostat Cover	-
11	R92097	1	Gasket, Turbocharger to Exhaust Manifold	-
12	RE527042	1	Gasket, Engine Major Overhaul	-
	TY6304	1	Sealant	-
13	R123352	1	Gasket, Oil Pan	-
14	R75892	1	O-ring, Oil Pump Tube Connector	-
15	R97185	1	O-ring, Oil Pump Outlet Tube to Cover	-
16	R61871	1	O-ring, Oil Pump Intake Tube	-
17	A4827R	1	Washer	-
18	RE44574	1	Seal, Rear Oil	-
19	RE59810	1	Seal Kit, Front Oil Seal	-
20	R123273	1	O-ring, Fuel Transfer Pump	-
21	R123417	1	Gasket, Water Pump	-
22	R136516	1	Gasket, Timing Gear Cover	-
	R136515	1	Gasket, Timing Gear Cover	-
23	R123501	1	Gasket, Oil Cooler Housing	-
24	R502864	1	Gasket, Remote Oil Filter Adapter	-
25	R123525	1	Gasket, Oil Filter Header	-
26	R53108	1	Gasket, Starting Motor	-
27	R72328	4	O-ring, Oil Filter Tubes	-
28	R89944	1	O-ring, Water Pump Inlet	-
29	R61105	2	O-ring, Connector Tube to Timing Gear Cover	-
30	T122075	2	O-ring, Oil Cooler to Housing	-
31	R501428	1	Gasket, Coolant Passage Adapter	-
32	R500374	1	Gasket, Oil Filter Header	-
33	RE526670	1	Gasket Kit, Cylinder Head Removal	-
34	RE526671	1	Gasket Kit, in Chassis Overhaul	-
35	R123353	1	Gasket, Engine Oil Pan	-
36	RE527042	1	Gasket Kit	-
	RE526671	1	Gasket Kit	-
37	16-15005	4	O-ring	-
38	16-01000	2	O-ring	-
39	16-31001	1	O-ring	-

GROUP 6 - GASKETS

Gasket Set, Engine Overhaul

KEY	PART NUMBER	QTY	DESCRIPTION	SERIAL NUMBER
L- M1064A Engine Gasket Set (continued)				
40	052300400	1	O-ring	-
41	11-31011	4	Gasket, Exhaust	-
42	11-30013	1	Gasket, Exhaust Flange	-
43	11-31401	1	Gasket, K26 Turbo Mounting	-
44	16-29502	2	O-ring	-
45	11-31031	1	Gasket, Turbo Oil Return	-
46	11-31012	1	Gasket	-
47	11-11022	1	Gasket, Filler Neck Mtg.	-
48	11-11023	1	Gasket, Manifold to Expansion Tank	-
49	11-10015	2	Thermostat Seal Ring	-
50	11-11013	1	Gasket, Thermostat Cover Mtg.	-
51	11-11043	1	Gasket, Expansion Tank Connection	-
52	16-19502	1	O-ring	-
53	16-14804	1	O-ring	-
54	16-19503	1	O-ring	-
55	16-19501	2	O-ring	-
56	15-09501	2	Sealing Washer, Copper M22	-
57	11-15704	2	Gasket, Block-off/ Adapter Mtg.	-
58	16-25701	1	O-ring	-
59	16-29501	1	O-ring	-
60	16-13101	2	O-ring	-
61	11-29501	1	Gasket, Aftercooler Mtg.	-
62	16-09401	2	O-ring	-
63	16-09504	2	O-ring	-
M1064H Engine Gasket Set				
••	29-09402	1	Gasket Set (includes all keys)	-
1	R123542	1	Gasket, Rocker Arm Cover	-
2	R521439	4	Gasket, Exhaust Manifold	-
3	R505479	1	Gasket, Thermostat Cover	-
4	R505480	1	Gasket, Water By-pass Tube	-
5	R123345	1	Gasket, Thermostat Housing	-
6	R505174	2	Gasket, Turbocharger Oil Outlet Tube	-
7	R123575	4	O-ring, Rocker Arm Cover Hold Down Stud	-
8	R116515	1	Engine Cylinder Head Gasket	-
9	R124607	1	Gasket, Thermostat Cover	-
10	R502916	1	Gasket	-
11	R123572	1	Gasket, Turbocharger to Exhaust Manifold	-
12	RE527010	1	Gasket, Engine Major Overhaul	-
	TY6304	1	Sealant	-
13	R123352	1	Gasket, Oil Pan	-
14	R75892	1	O-ring, Oil Pump Tube Connector	-
15	R516158	5	O-ring, Oil Pump Outlet Tube to Cover	-
16	R63185	2	O-ring, Oil Pump Intake Tube	-
17	A4827R	1	Washer	-
18	RE44574	1	Seal, Rear Oil	-
19	RE59810	1	Seal Kit, Front Oil Seal	-
20	R123273	1	O-ring, Fuel Transfer Pump	-
21	R123417	1	Gasket, Water Pump	-
22	R136516	1	Gasket, Timing Gear Cover	-
	R136515	1	Gasket, Timing Gear Cover	-
23	R123501	1	Gasket, Oil Cooler Housing	-
24	R502864	1	Gasket, Remote Oil Filter Adapter	-

Gasket Set, Engine Overhaul

KEY	PART NUMBER	QTY	DESCRIPTION	SERIAL NUMBER
			M1064H Engine Gasket Set (continued)	
25	R123525	1	Gasket, Oil Filter Header	
26	R53108	1	Gasket, Starting Motor	-
27	R72328	4	O-ring, Oil Filter Tubes	-
28	R89944	1	O-ring, Water Pump Inlet	-
29	R61105	2	O-ring, Connector Tube to Timing Gear Cover	-
30	T122075	2	O-ring, Oil Cooler to Housing	-
31	R501428	1	Gasket, Coolant Passage Adapter	-
32	R500374	1	Gasket, Oil Filter Header	-
33	RE526670	1	Gasket Kit, Cylinder Head Removal	-
34	RE526671	1	Gasket Kit, in Chassis Overhaul	-
35	R123353	1	Gasket, Engine Oil Pan	-
36	RE527010	1	Gasket Kit	-
37	16-15005	6	O-ring	-
38	16-01000	2	O-ring	-
39	16-31001	2	O-ring	-
40	052300400	1	O-ring	-
41	11-31011	8	Gasket, Exhaust	-
42	11-30013	1	Gasket, Exhaust Flange	-
43	11-31401	1	Gasket, K26 Turbo Mounting	-
44	11-39501	2	Gasket, Coolant Port Adapter Mtg.	-
45	11-31031	1	Gasket, Turbo Oil Return	-
46	11-31012	1	Gasket	-
47	11-11022	1	Gasket, Filler Neck Mtg.	-
48	11-11023	1	Gasket, Manifold to Expansion Tank	-
49	11-10015	2	Thermostat Seal Ring	-
50	11-11013	1	Gasket, Thermostat Cover Mtg.	-
51	11-11043	1	Gasket, Expansion Tank Connection	-
52	16-19502	1	O-ring	-
53	16-14804	1	O-ring	-
54	16-19503	1	O-ring	-
55	16-19501	2	O-ring	-
56	15-09501	2	Sealing Washer, Copper M22	-
57	11-15704	2	Gasket, Block-off/ Adapter Mtg.	-
58	16-25701	1	O-ring	-
59	16-29501	1	O-ring	-
60	16-13101	2	O-ring	-
61	16-09504	2	O-ring	-
62	16-09401	2	O-ring	-
			NL1064D, T1, T2, H1, H2 Engine Gasket Set	
••	RE527042	1	Gasket Kit NL1064D, T1, T2, H1	-
••	RE527010	1	Gasket Kit NL1064H2	-
1	R123542	1	Gasket, Rocker Arm Cover	-
2	R521439	4	Gasket, Exhaust Manifold	-
3	R135896	1	Gasket, Thermostat Cover NL1064D, T1, T2, H1	-
	R505479	1	Gasket, Thermostat Cover NL1064H2	-
4	R123226	1	Gasket, Water By-pass Tube NL1064D, T1, T2, H1	-
	R505480	1	Gasket, Water By-pass Tube NL1064H2	-
5	R123345	1	Gasket, Thermostat Housing	-
6	R123570	2	Gasket, Turbocharger Oil Outlet Tube NL1064D, T1, T2, H1	-
	R505174	2	Gasket, Turbocharger Oil Outlet Tube NL1064H2	-

GROUP 6 - GASKETS

Gasket Set, Engine Overhaul

KEY	PART NUMBER	QTY	DESCRIPTION	SERIAL NUMBER
			NL1064D, T1, T2, H1, H2 Engine Gasket Set (continued)	
7	R123575	4	O-ring, Rocker Arm Cover Hold Down Stud	
8	R116515	1	Engine Cylinder Head Gasket	-
9	R501373	1	Gasket, Thermostat Cover NL1064D, T1, T2, H1	-
	R124607	1	Gasket, Thermostat Cover NL1064H	-
10	R502916	1	Gasket	-
11	R92097	1	Gasket, Turbocharger to Exhaust Manifold NL1064D, T1, T2, H1	-
	R123572	1	Gasket, Turbocharger to Exhaust Manifold NL1064H	-
12	R123353	1	Gasket, Engine Oil Pan	-
13	R123352	1	Gasket, Oil Pan	-
14	R75892	1	O-ring, Oil Pump Tube Connector	-
15	R97185	1	O-ring, Oil Pump Outlet Tube to Cover	-
	R516158	1	O-ring, Oil Pump Outlet Tube to Cover NL1064H	
16	R61871	1	O-ring, Oil Pump Intake Tube	
	R63185	2	O-ring, Oil Pump Intake Tube NL1064H	-
17	A4827R	1	Washer	-
18	RE44574	1	Seal, Rear Oil	-
19	RE59810	1	Seal Kit, Front Oil Seal	-
20	R123273	1	O-ring, Fuel Transfer Pump	-
21	R123417	1	Gasket, Water Pump	-
22	R136516	1	Gasket, Timing Gear Cover	-
	R136515	1	Gasket, Timing Gear Cover	-
23	R123501	1	Gasket, Oil Cooler Housing	-
24	R502864	1	Gasket, Remote Oil Filter Adapter	-
25	R123525	1	Gasket, Oil Filter Header	
26	R53108	1	Gasket, Starting Motor	-
27	R72328	4	O-ring, Oil Filter Tubes	-
28	R89944	1	O-ring, Water Pump Inlet	-
29	R61105	2	O-ring, Connector Tube to Timing Gear Cover	-
30	T122075	2	O-ring, Oil Cooler to Housing	-
31	R501428	1	Gasket, Coolant Passage Adapter	-
32	R500374	1	Gasket, Oil Filter Header	-

Gear Oil Cooler Heat Exchanged Units

L1064D - T1

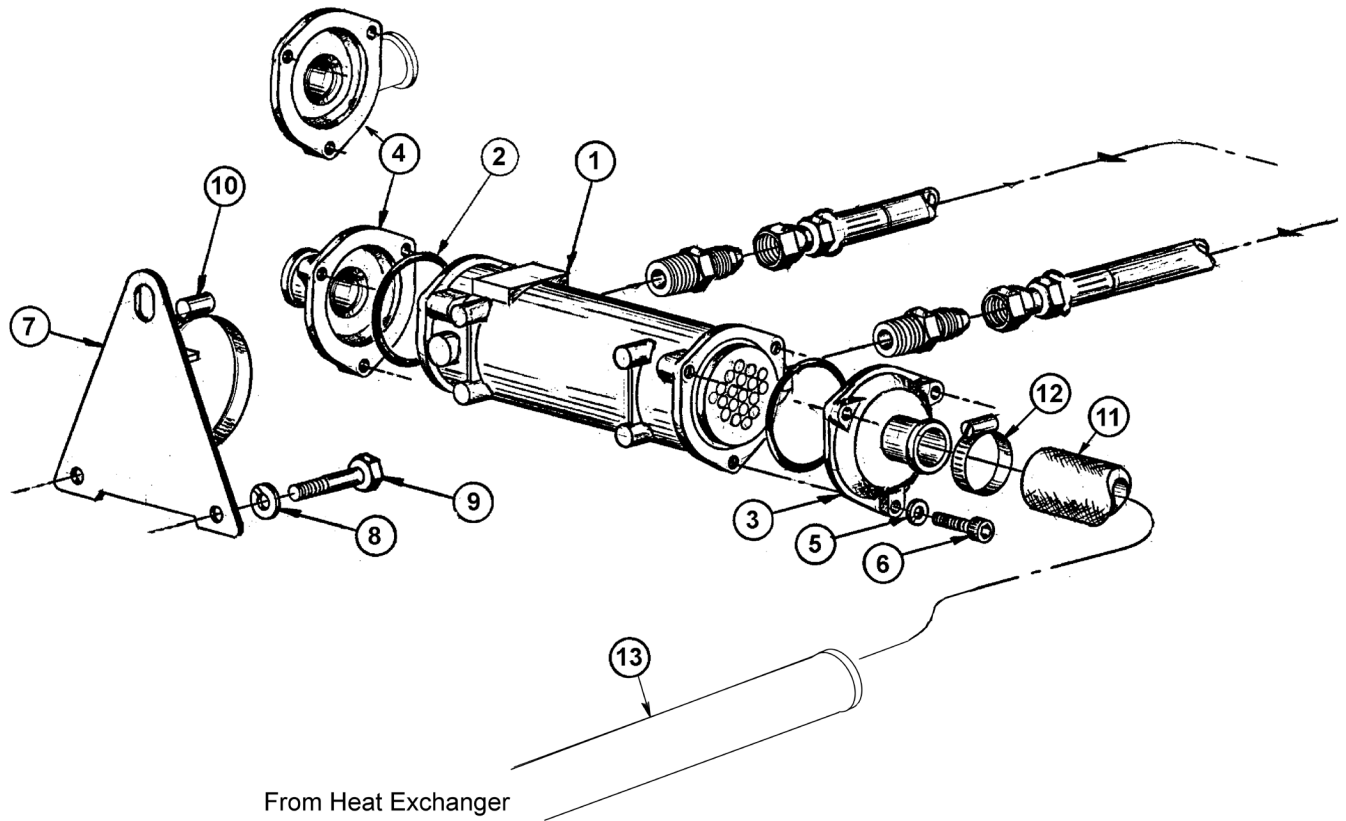

A-5005/ C-2541A

KEY	PART NUMBER	QTY	DESCRIPTION	SERIAL NUMBER
1	20-62500	1	Gear Oil Cooler	-
2	16-10001	2	O-ring	-
3	20-61039	1	End Cover 1-1/4" HB with drain	-
4	20-61040	1	End Cover 1-1/4" Hose Barb without drain	-
	20-61038	1	End Cover 90° 1-1/4" Hose Barb (units with wet exhaust elbow)	-
5	15-01132	6	Lock Washer, Helical M6	-
6	12-00072	6	Capscrew, Socket Head M6 x 1.0 x 30 mm	-
7	23-61001	1	Lifting Eye/ Gear Oil Cooler Mtg.	-
8	15-00802	2	Lock Washer, Helical M10	-
9	12-00814	2	Capscrew, Hex Head M10 x 1.5 x 35 mm	-
10	19-00056	1	Hose Clamp #56	-
11	41-01070	20"	Hose 1-1/4" ID Wire Reinforced	-
12	19-00020	1	Hose Clamp #20	-
13	27-19401	1	Tube	-

GROUP 7 - GEAR AND ADAPTER PARTS

Gear Oil Cooler Heat Exchanged Units

L1064A

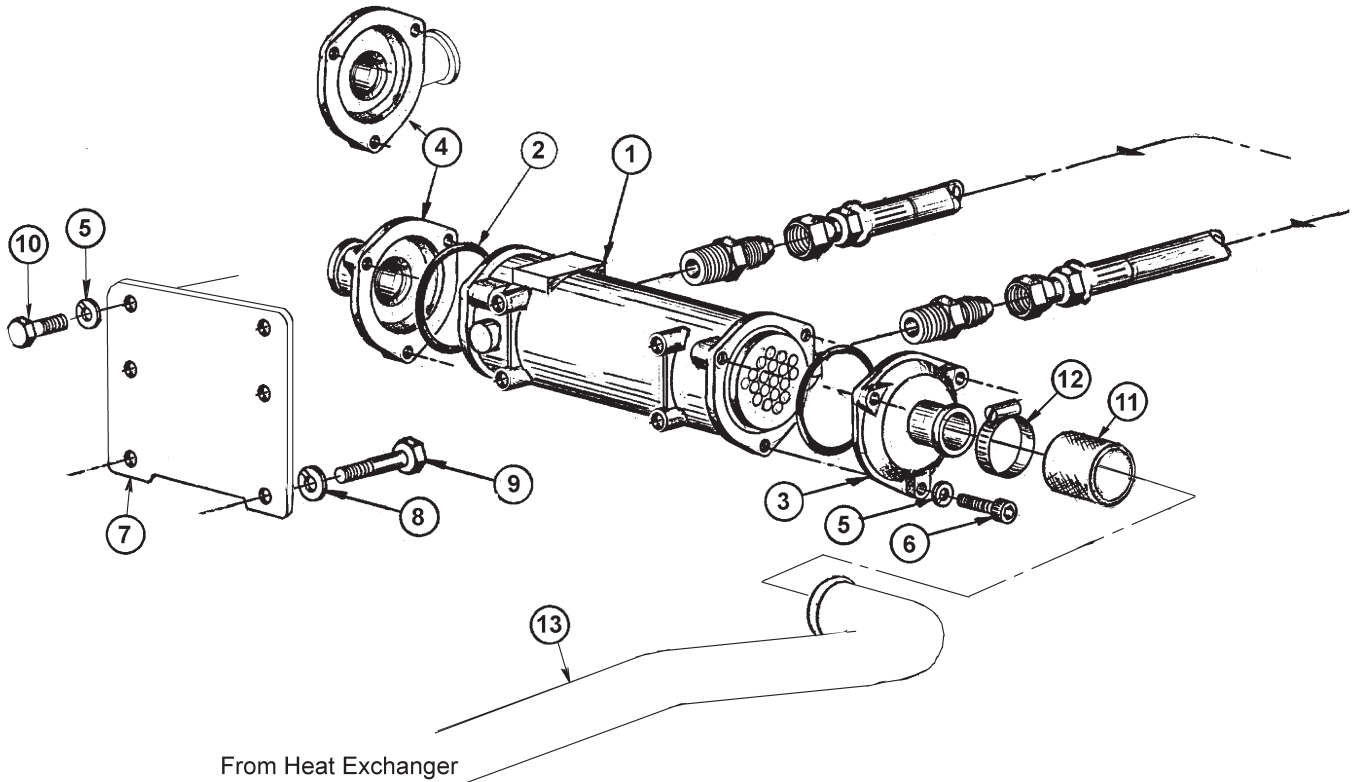

A-5005/ C-2541Aver2

KEY	PART NUMBER	QTY	DESCRIPTION	SERIAL NUMBER
1	20-62500	1	Gear Oil Cooler	-
2	16-10001	2	O-ring	-
3	20-61086	1	End Cover 1-3/4" HB with drain	-
4	20-61087	1	End Cover 1-3/4" Hose Barb without drain	-
	20-61088	1	End Cover 90° 1-1/4" Hose Barb (units with wet exhaust elbow)	-
5	15-01132	10	Lock Washer, Helical M6	-
6	12-00072	6	Capscrew, Socket Head M6 x 1.0 x 30 mm	-
7	23-69402	1	Gear Oil Cooler Mtg.	-
8	15-00802	2	Lock Washer, Helical M10	-
9	12-00816	2	Capscrew, Hex Head M10 x 1.5 x 50 mm	-
10	12-00030	4	Capscrew, Hex Head M6 x 1.0 x 16 mm	-
11	18-12511	1	Hose 1-3/4" ID x 3"	-
12	19-00028	2	Hose Clamp #28	-
13	27-69401	1	Tube	-

Gear Oil Cooler Keel Cooled Units

L1064D - T1

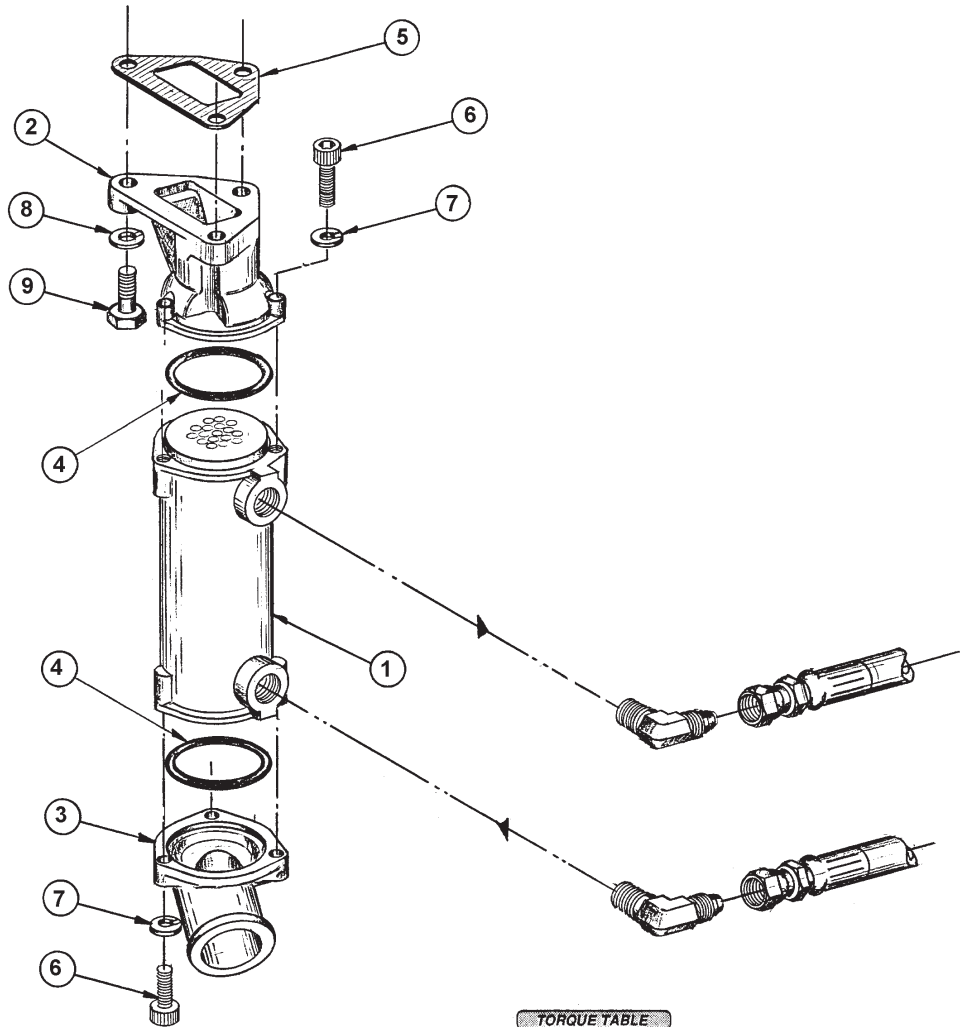

TORQUE TABLE

ITEM	THREAD SIZE	FT	LB	KPM
6	M6 x 1.0 SKT HD	3.9		0.53

A-4929A/ C-2529

KEY	PART NUMBER	QTY	DESCRIPTION	SERIAL NUMBER
1	20-62500	1	Gear Oil Cooler	-
2	10-12510	1	Adapter	-
3	20-61089	1	End Cover, 90° 2-3/8" Hose Barb	-
4	16-10001	2	O-ring	-
5	11-11043	1	Gasket	-
6	12-00072	6	Capscrew, Socket Head M6 x 1.0 x 30 mm	-
7	15-01132	6	Lock Washer, Helical M6	-
8	15-00302	3	Lock Washer, Helical 3/8	-
9	12-00313	3	Capscrew, Hex Head 3/8-16 x 1-1/4"	-

Notes

Base Frame with Centerbonded Mounts

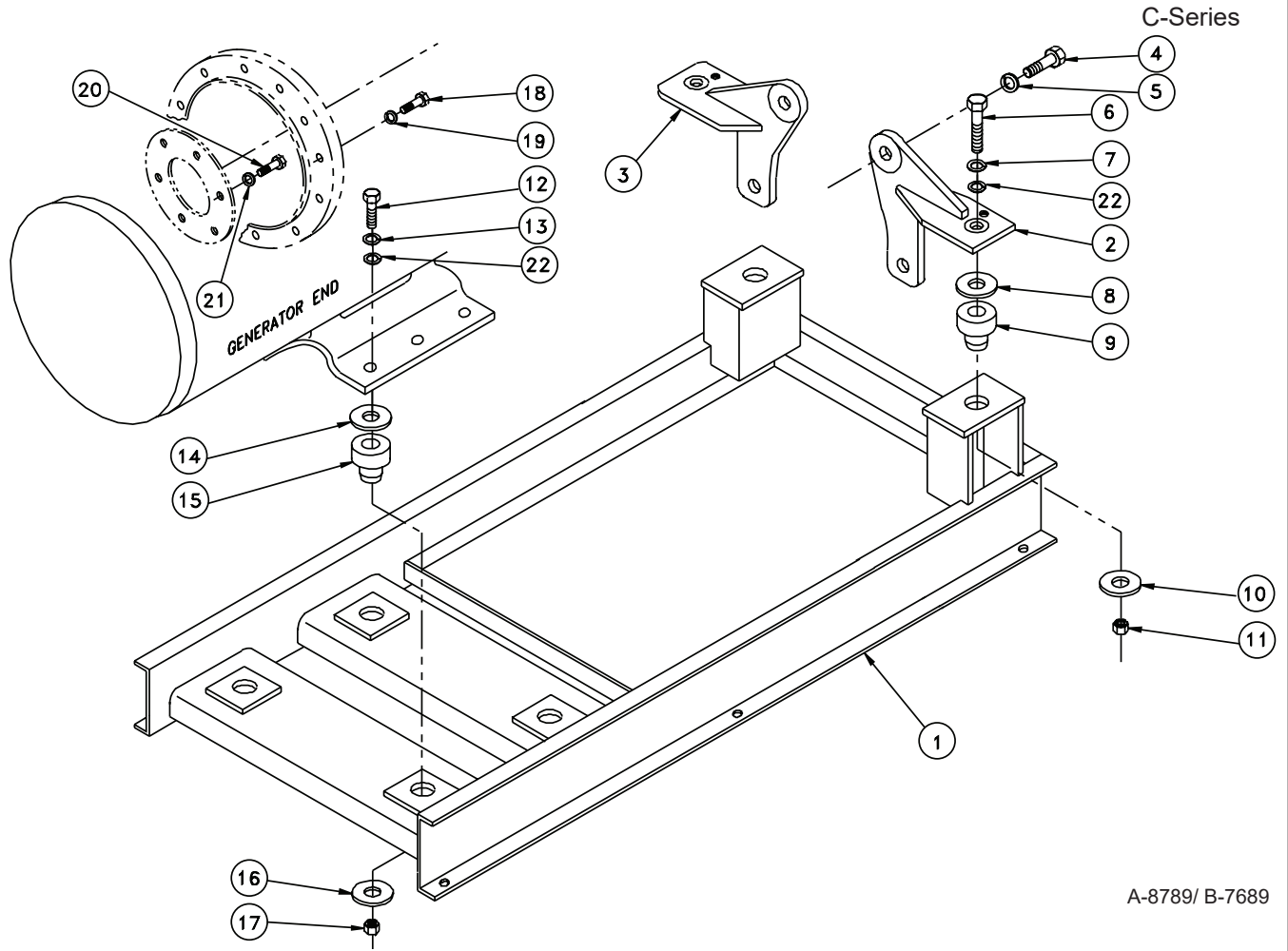

A-8789/ B-7689

KEY	PART NUMBER	QTY	DESCRIPTION	SERIAL NUMBER
1	39-81013	1	Base Frame, Steel	-
	39-81044	1	Base Frame, Aluminum	-
2	23-81001	1	Bracket, Front Engine Mtg., Right Hand	-
3	23-81002	1	Bracket, Front Engine Mtg., Left Hand	-
4	12-04803	4	Capscrew, Hex Head M16 x 2.0 x 40 mm	-
5	15-01000	4	Lock Washer, M16	-
6	12-00550	2	Capscrew, Hex Head, 1/2 -13 x 3"	-
7	15-00501	2	Flat Washer, 1/2" USS	-
8	15-00016	2	Head Washer	-
9	33-81054	2	Centerbonded Mount 400 Lbs.	-
10	15-00026	2	Tail Washer	-
11	14-00512	2	Hex Nut, Nylock 1/2 -13	-
12	12-00519	4	Capscrew, Hex Head, 1/2 -13 x 2 -3/4"	-
13	15-00501	4	Flat Washer, 1/2" USS	-
14	15-00016	4	Head Washer	-
15	33-81054	4	Centerbonded Mount 400 Lbs.	-
16	15-00026	4	Tail Washer	-
17	14-00512	4	Hex Nut, Nylock 1/2 -13	-
18	12-00814	12	Capscrew, Hex Head, M10 x 1.5 x 35 mm	-
19	15-00802	12	Lock Washer, Helical M10	-
20	12-00312	8	Capscrew, Hex Head, 3/8 -16 x 1"	-
21	15-00302	8	Lock Washer, Helical 3/8	-
22	15-00510	6	Lock Washer, Hi-collar 1/2"	-

GROUP 8 - FRAMES AND MOUNTING

Base Frame with Hydrolastic Mounts (Early Production)

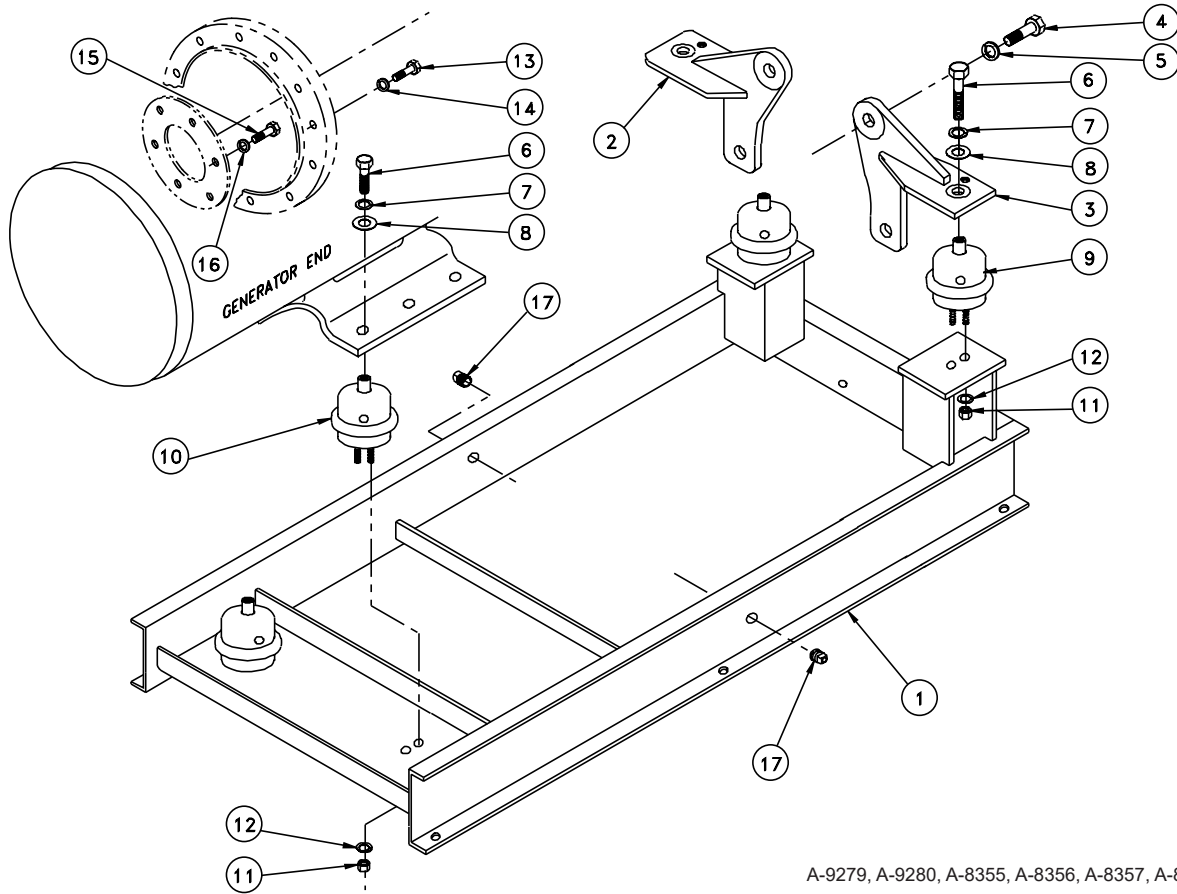

A-9279, A-9280, A-8355, A-8356, A-8357, A-8358 / B-7682

KEY	PART NUMBER	QTY	DESCRIPTION	SERIAL NUMBER
1	39-81032	1	Base Frame, Steel	-
	39-81041	1	Base Frame, Aluminum	-
2	23-81002	1	Bracket, Front Engine Mtg., Left Hand	-
3	23-81001	1	Bracket, Front Engine Mtg., Right Hand	-
4	12-04803	4	Capscrew, Hex Head M16 x 2.0 x 40 mm	-
5	15-01000	4	Lock Washer, M16	-
6	12-00913	4	Cap Screw, Hex Head, 5/8 -11 x 1 -1/2"	-
7	15-00902	4	Lock Washer, Helical 5/8	-
8	15-00901	2	Flat Washer 5/8" USS (Rear)	-
	15-01330	2	Flat Washer 5/8" SAE (Front)	-
9	33-81012	2	Hydrolastic Mount 400 lbs. (all) *	-
10	33-81012	2	Hydrolastic Mount 400 lbs. (M1064D all)	-
	33-81013	2	Hydrolastic Mount 500 lbs. (M1064T1 all, M1064T2 - 3 Phase)	-
	33-81014	2	Hydrolastic Mount 600 lbs. (M1064T2 -1 Phase & M1064A,H - 3 Phase)	-
11	14-00511	8	Hex Nut 1/2 -13	-
12	15-00502	8	Lock Washer, Helical 1/2"	-
13	12-00814	12	Capscrew, Hex Head, M10 x 1.5 x 35 mm	-
14	15-00802	12	Lock Washer, Helical M10	-
15	12-00311	8	Capscrew, Hex Head, 3/8 -16 x 3/4"	-
16	15-00302	8	Lock Washer, Helical 3/8	-
17	21-00530	2	Plug, Hex Head, Brass 1/2 NPT	-
<p>* Note: Mounts listed are for units without front PTO and are stamped #14 on upper portion of housing. Mounts provided on applications with PTO are stamped #15, #16, or #17. Contact dealer or factory for part numbers required. Have unit serial # available.</p>				

Base Frame with Hydrolastic Mounts (Late Production)

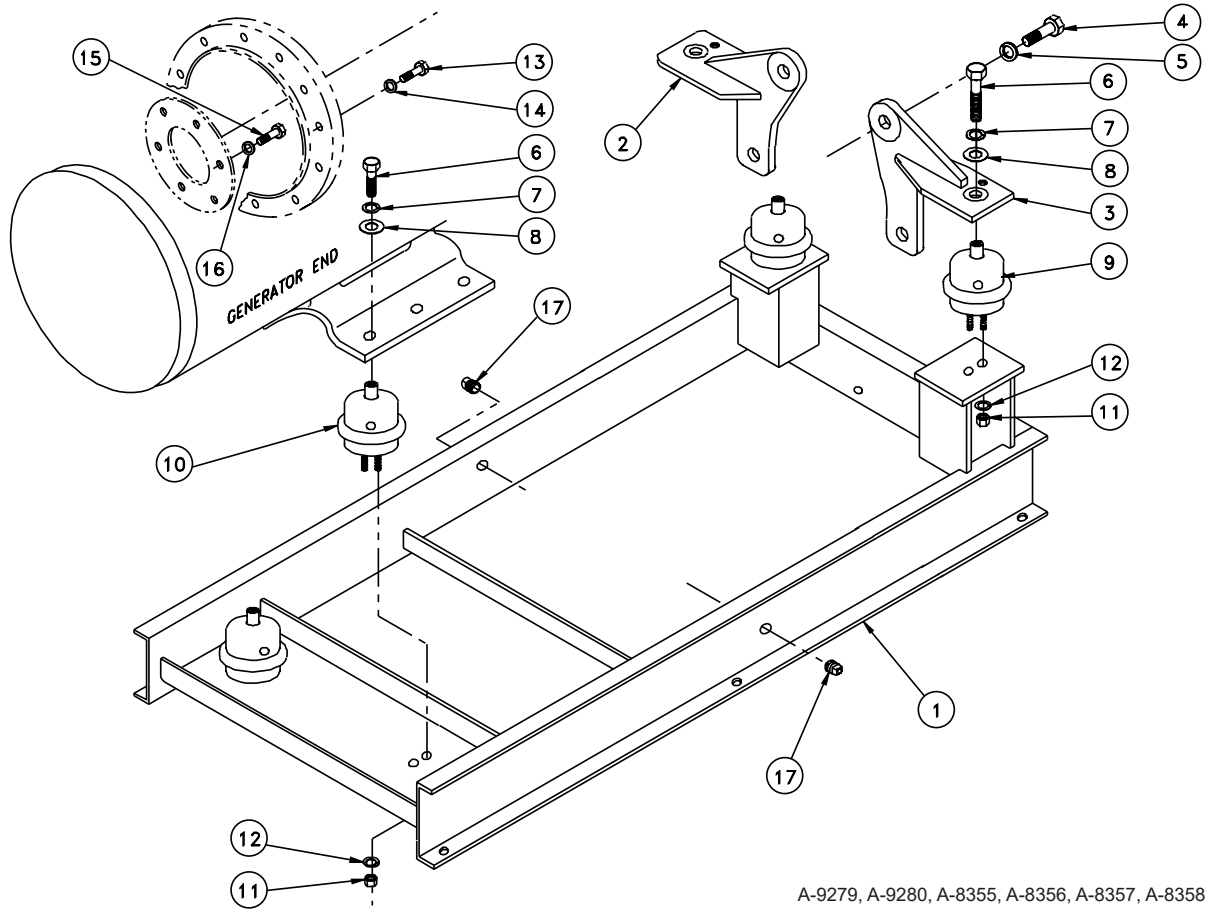

A-9279, A-9280, A-8355, A-8356, A-8357, A-8358 / B-7682

KEY	PART NUMBER	QTY	DESCRIPTION	SERIAL NUMBER
1	39-89403	1	Base Frame, Steel	-
	39-89404	1	Base Frame, Aluminum	-
2	23-81002	1	Bracket, Front Engine Mtg., Left Hand	-
3	23-81001	1	Bracket, Front Engine Mtg., Right Hand	-
4	12-04803	4	Capscrew, Hex Head M16 x 2.0 x 40 mm	-
5	15-01000	4	Lock Washer, M16	-
6	12-00913	4	Capscrew, Hex Head, 5/8 -11 x 1 -1/2"	-
7	15-00902	4	Lock Washer, Helical 5/8	-
8	15-00901	2	Flat Washer 5/8" USS (Rear)	-
	15-01330	2	Flat Washer 5/8" SAE (Front)	-
9	33-81012	2	Hydrolastic Mount 400 lbs. (all) *	-
10	33-81012	2	Hydrolastic Mount 400 lbs. (M1064D all)	-
	33-81013	2	Hydrolastic Mount 500 lbs. (M1064T1 all & M1064T2- 3 Phase)	-
	33-81014	2	Hydrolastic Mount 600 lbs. (M1064T2- 1 Phase & M1064A-H- 3 Phase)	-
11	14-00511	8	Hex Nut 1/2 -13	-
12	15-00502	8	Lock Washer, Helical 1/2"	-
13	12-00814	12	Capscrew, Hex Head, M10 x 1.5 x 35 mm	-
14	15-00802	12	Lock Washer, Helical M10	-
15	12-00311	8	Capscrew, Hex Head, 3/8 -16 x 3/4"	-
16	15-00302	8	Lock Washer, Helical 3/8	-
17	21-00530	2	Plug, Hex Head, Brass 1/2 NPT	-
<p>* Note: Mounts listed are for units without front PTO and are stamped #14 on upper portion of housing. Mounts provided on applications with PTO are stamped #15, #16, or #17. Contact dealer or factory for part numbers required. Have unit serial # available.</p>				

GROUP 8 - FRAMES AND MOUNTING

Base Frame with Centerbonded Mounting

M1064T2MCA

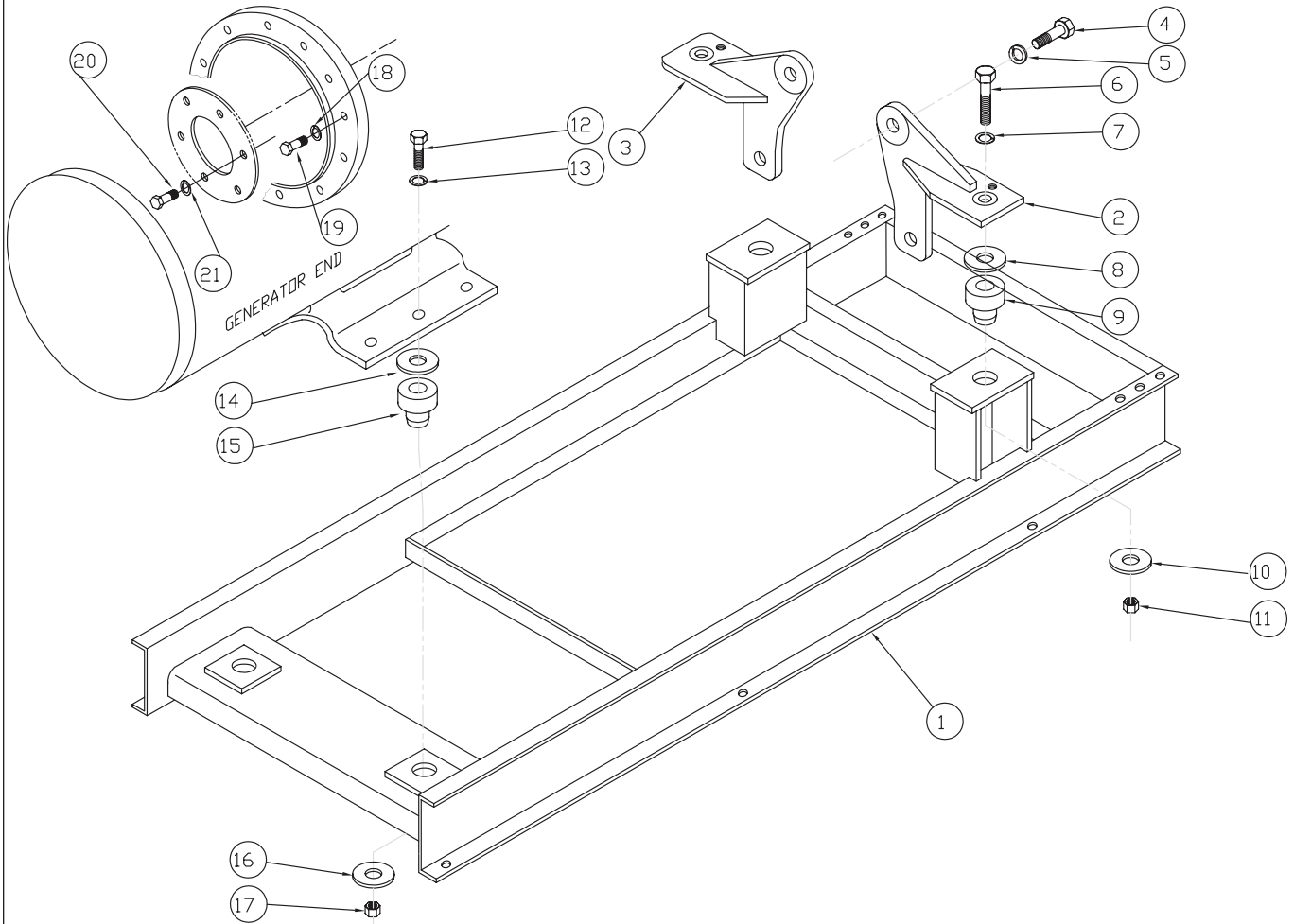

B-9736

Base Frame with Centerbonded Mounting

M1064T2MCA

KEY	PART NUMBER	QTY	DESCRIPTION	SERIAL NUMBER
1	29-89414	1	Base Frame, Steel	-
	39-89422	1	Base Frame, Aluminum (Canadian Coast Guard Special)	-
2	23-81001	1	Bracket, Front Engine Mounting, R. H.	-
3	23-81002	1	Bracket, Frount Engine Mounting, L.H.	-
4	12-04803	4	Capscrew, Hex Head M16 x 2.0 x 40mm	-
5	15-01000	4	Lock Washer, Helitical	-
6	12-00034	2	Capscrew, Hex Head 5/8-11 x 3-1/2"	-
7	15-01330	2	Flat Washer, 5/8"	-
8	15-00015	2	Head Washer, 2.75" x 0.64" x 0.125"	-
9	33-81002	2	Mount, Centerbonded 500 Lb	-
10	15-00025	2	Tail Washer, 2.50" x 0.64" x 0.125"	-
11	14-00912	2	Hex Nut, Nylock	-
12	12-00034	2	Capscrew, Hex Head 5/8-11 x 3-1/2"	-
13	15-00901	2	Flat Washer 5/8"	-
14	15-00015	2	Head Washer, 2.75" x 0.64" x 0.125"	-
15	33-81002	2	Mount, Centerbonded 500 Lb	-
16	15-00025	2	Tail Washer, 2.50" x 0.64" x 0.125"	-
17	14-00912	2	Hex Nut, Nylock	-
18	12-00814	12	Capscreew, Hex Head M10x1.5 x 35mm	-
19	15-00802	12	Lock Washer, Helitical	-
20	12-00332	8	Capscrew, Hex Head 3/8-16 x 1"	-
21	15-00307	8	Flat Washer, 3/8"	-
22	21-00530	2	Pluc, Hex Head, Brass	-

Base Frame with Centerbonded Mounts

M1064H Radiator Cooled

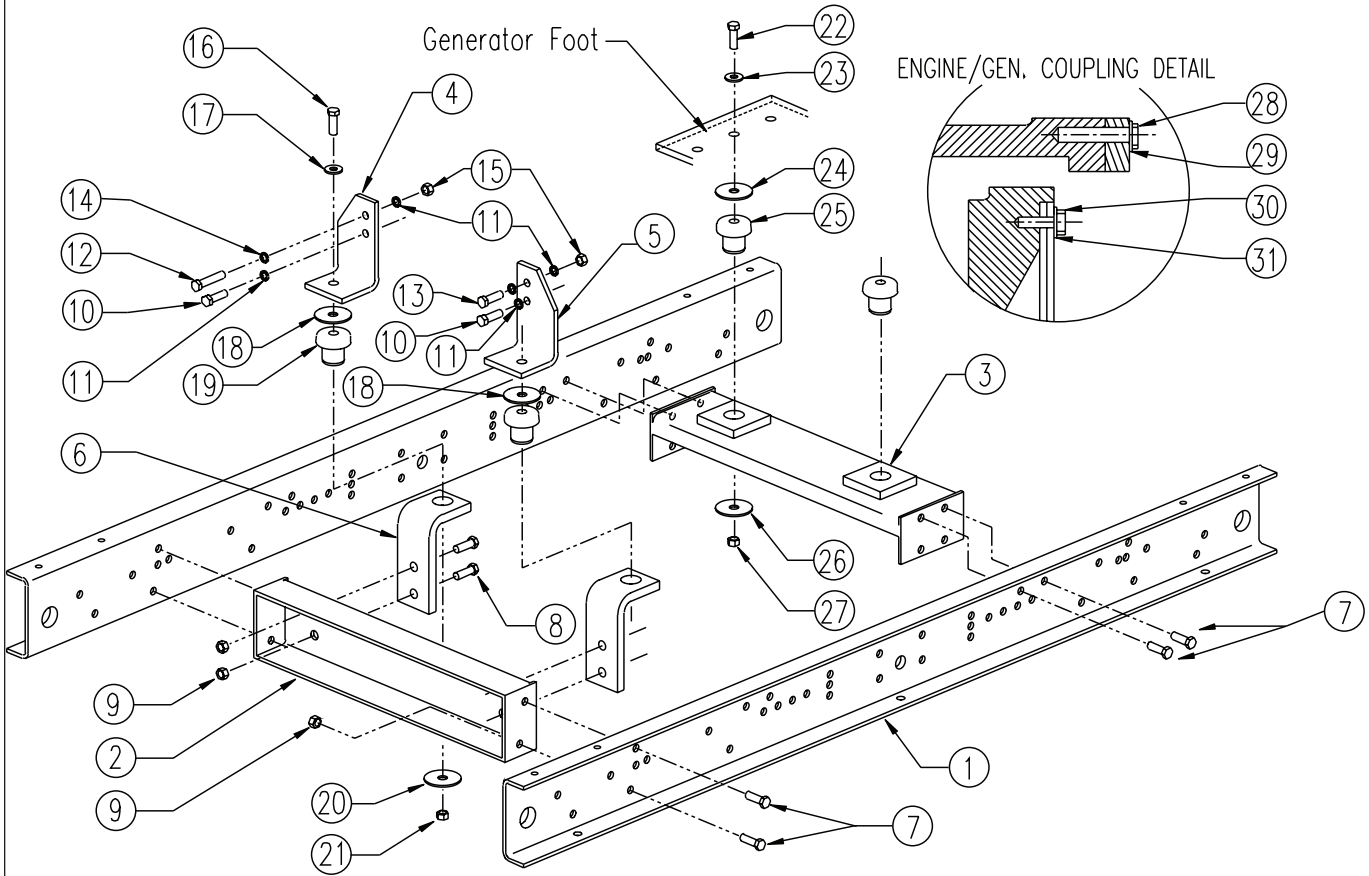

A-11797 / D-4354

Base Frame with Centerbonded Mounts

M1064H Radiator Cooled

KEY	PART NUMBER	QTY	DESCRIPTION	SERIAL NUMBER
1	39-88406	2	Side Rail	-
2	39-81014	1	Engine Support	-
3	39-88407	1	Generator Support	-
4	23-81035	1	Bracket, Front Engine Mounting, Right Hand	-
5	23-81036	1	Bracket, Front Engine Mounting, Left Hand	-
6	23-81037	2	Bracket, Engine Support	-
7	12-80513	10	Capscrew, Hex Head Flanged 1/2 -13 x 1 -1/4"	-
8	12-80514	4	Capscrew, Hex Head Flanged 1/2 -13 x 1 -1/2"	-
9	14-00502	14	Lock Nut, Plain Flanged 1/2 -13	-
10	12-04803	2	Capscrew, Hex Head, M16 x 2.0 x 40 mm	-
11	15-01000	4	Lock Washer, Helical M16	-
12	12-01512	1	Capscrew, Hex Head, M16 x 2.0 x 70 mm	-
13	12-01504	1	Capscrew, Hex Head, M16 x 2.0 x 60 mm	-
14	01643-31645	2	Flat Washer M16	-
15	14-01432	2	Hex Nut M16 x 2.0	-
16	12-00034	2	Capscrew, Hex Head, 5/8 -11 x 3 -1/2"	-
17	15-01330	2	Flat Washer 5/8" SAE	-
18	15-00015	2	Head Washer	-
19	33-81002	2	Centerbonded Mount, 500 Lbs.	-
20	15-00025	2	Tail Washer	-
21	14-00912	2	Hex Nut, Nylock	-
22	12-00034	2	Capscrew, Hex Head, 5/8 -11 x 3 -1/2"	-
23	15-01330	2	Flat Washer 5/8" SAE	-
24	15-00015	2	Head Washer	-
25	33-81002	2	Centerbonded Mount, 500 lbs. (NL445D1)	-
	33-81008	2	Centerbonded Mount, 650 lbs. (NL445T1 & T2)	-
26	15-00025	2	Tail Washer	-
27	14-00912	2	Hex Nut, Nylock	-
28	12-00814	12	Capscrew, Hex Head, M10 x 1.5 x 35 mm	-
29	15-00802	12	Lock Washer, Helical M10	-
30	12-00312	8	Capscrew, Hex Head, 3/8 -16 x 1"	-
31	15-00302	8	Lock Washer, Helical 3/8	-

GROUP 8 - FRAMES AND MOUNTING

Base Frame with Centerbonded Mounts

NL1064D - NL1064T1 - NL1064T2 - NL1064H2 @ 50 Hz

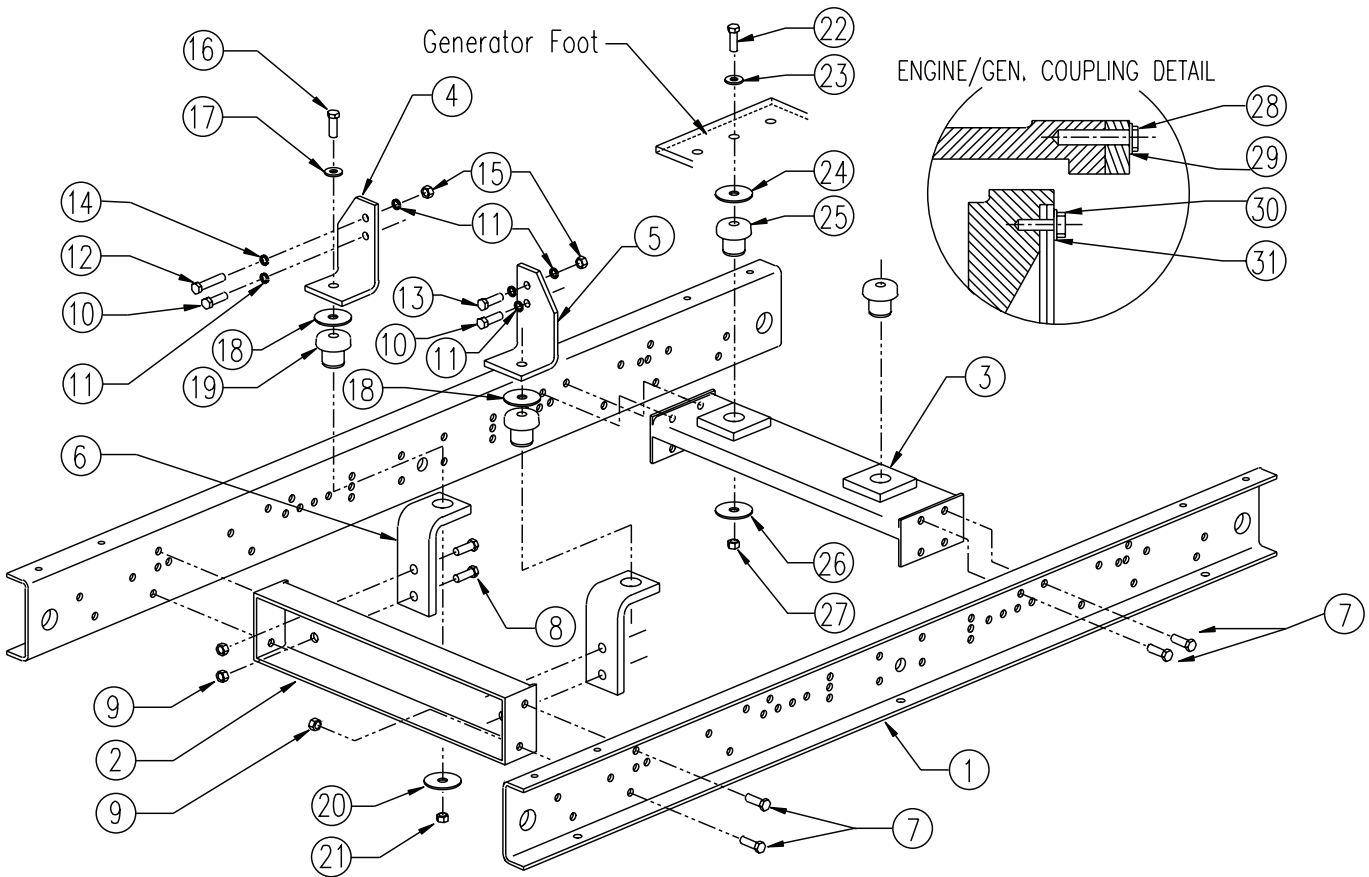

A-8047A, A-8085A/ D-3178A

Base Frame with Centerbonded Mounts

NL1064D - NL1064T1 - NL1064T2 - NL1064H2 @ 50 Hz

KEY	PART NUMBER	QTY	DESCRIPTION	SERIAL NUMBER
1	39-81002	2	Side Rail	-
2	39-81014	1	Engine Support	-
3	39-81004	1	Generator Support	-
4	23-81035	1	Bracket, Front Engine Mounting, Right Hand	-
5	23-81036	1	Bracket, Front Engine Mounting, Left Hand	-
6	23-81037	2	Bracket, Engine Support	-
7	12-80513	8	Capscrew, Hex Head Flanged 1/2 -13 x 1 -1/4"	-
8	12-80514	4	Capscrew, Hex Head Flanged 1/2 -13 x 1 -1/2"	-
9	14-00502	12	Lock Nut, Plain Flanged 1/2 -13	-
10	12-04803	2	Capscrew, Hex Head, M16 x 2.0 x 40 mm	-
11	15-01000	4	Lock Washer, Helical M16	-
12	12-01512	1	Capscrew, Hex Head, M16 x 2.0 x 70 mm	-
13	12-01504	1	Capscrew, Hex Head, M16 x 2.0 x 60 mm	-
14	01643-31645	2	Flat Washer M16	-
15	14-01432	2	Hex Nut M16 x 2.0	-
16	12-00034	2	Capscrew, Hex Head, 5/8 -11 x 3 -1/2"	-
17	15-01330	2	Flat Washer 5/8" SAE	-
18	15-00015	2	Head Washer	-
19	33-81002	2	Centerbonded Mount, 500 Lbs.	-
20	15-00025	2	Tail Washer	-
21	14-00912	2	Hex Nut, Nylock	-
22	12-00034	2	Capscrew, Hex Head, 5/8 -11 x 3 -1/2"	-
23	15-01330	2	Flat Washer 5/8" SAE	-
24	15-00015	2	Head Washer	-
25	33-81002	2	Centerbonded Mount, 500 lbs. (NL1064D	-
	33-81008	2	Centerbonded Mount, 650 lbs. (NL1064T1 & T2)	-
26	15-00025	2	Tail Washer	-
27	14-00912	2	Hex Nut, Nylock	-
28	12-00814	12	Capscrew, Hex Head, M10 x 1.5 x 35 mm	-
29	15-00802	12	Lock Washer, Helical M10	-
30	12-00312	8	Capscrew, Hex Head, 3/8 -16 x 1"	-
31	15-00302	8	Lock Washer, Helical 3/8	-

GROUP 8 - BASE FRAME AND MOUNTING

Base Frame

NL1064H1 & NL1064H2 @ 60 Hz

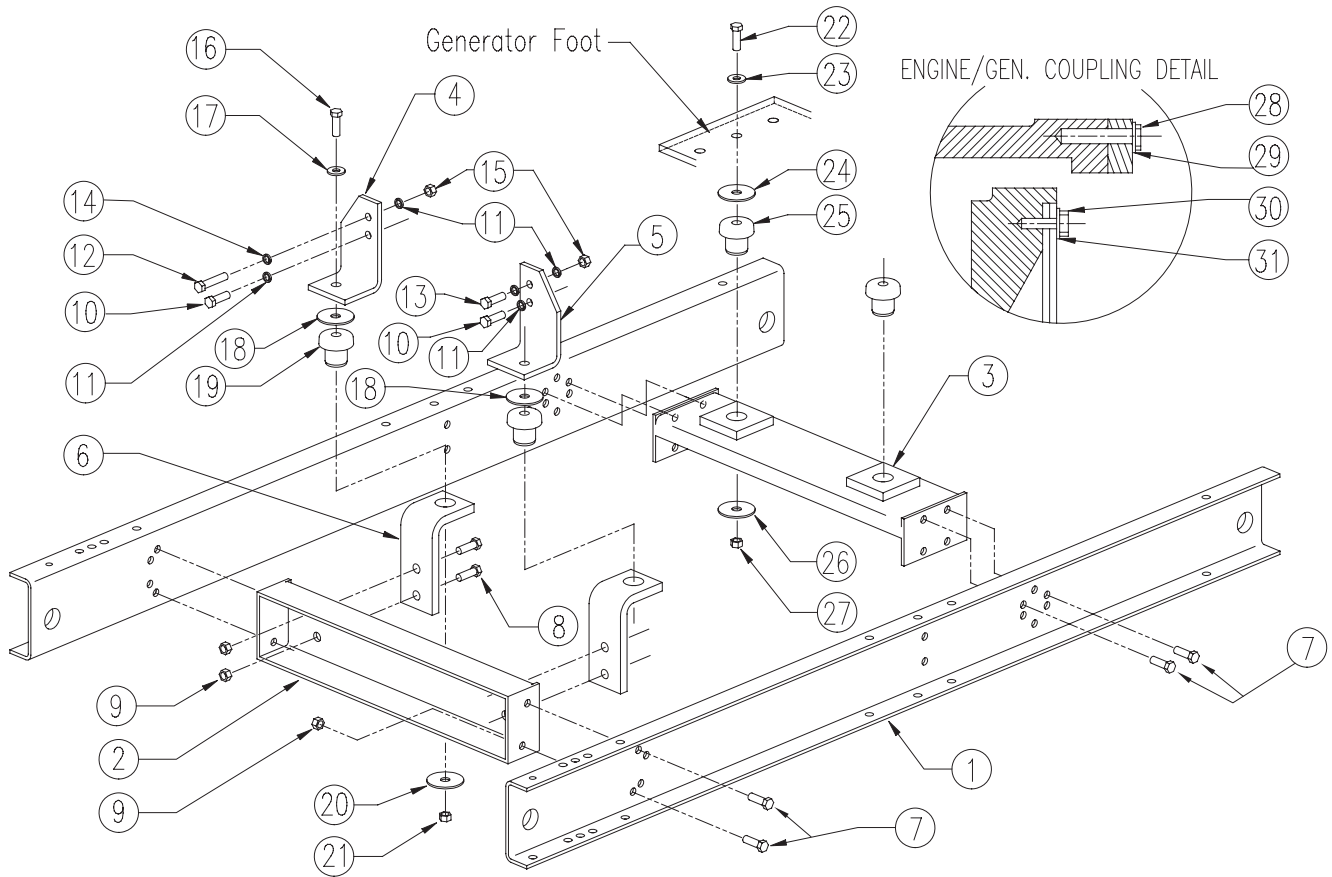

A-8339A/ D-3180A

Base Frame

NL1064H1 & NL1064H2 @ 60 Hz

KEY	PART NUMBER	QTY	DESCRIPTION	SERIAL NUMBER
1	39-81002	2	Side Rail, Modular Base Frame	-
2	39-81014	1	Engine Support, Modular Base Frame	-
3	39-81046	1	Support, M363 Generator, Modular Base Frame	-
4	23-81035	1	Bracket, Front Engine Mtg. Right Hand	-
5	23-81036	1	Bracket, Front Engine Mtg. Left Hand	-
6	23-81037	2	Bracket, Engine Support	-
7	12-80513	10	Capscrew, Hex Head Flanged 1/2- 13 x 1- 1/4"	-
8	12-80514	4	Capscrew, Hex Head Flanged 1/2- 13 x 1- 1/2"	-
9	14-00502	14	Lock Nut, Plain Flanged 1/2- 13	-
10	12-04803	2	Capscrew, Hex Head M16 x 2.0 x 40 mm	-
11	15-01000	4	Lock Washer, Helical M16	-
12	12-01512	1	Capscrew, Hex Head M16 x 2.0 x 70 mm (Grade 8.8)	-
13	12-01504	1	Capscrew, Hex Head M16 x 2.0 x 60 mm	-
14	01643-31645	2	Flat Washer M16	-
15	14-01432	2	Hex Nut M16 x 2.0	-
16	12-00034	2	Capscrew, Hex Head 5/8- 11 x 3- 1/2"	-
17	15-01330	2	Flat Washer 5/8" SAE	-
18	15-00015	2	Head Washer	-
19	33-81002	2	Mount, Centerbonded 500 lbs.	-
20	15-00025	2	Tail Washer	-
21	14-00912	2	Hex Nut, Nylock	-
22	12-01222	2	Capscrew, Hex Head 3/4- 10 x 4"	-
23	15-01211	2	Flat Washer 3/4"	-
24	15-85000	2	Head Washer	-
25	33-81011	2	Mount, Centerbonded 800 lbs.	-
26	15-85001	2	Tail Washer	-
27	14-01212	2	Hex Nut, Nylock 3/4- 10	-
28	12-00814	12	Capscrew, Hex Head M10 x 1.5 x 35 mm	-
29	15-00802	12	Lock Washer, Helical M10	-
30	12-00332	8	Capscrew, Hex Head 3/8- 16 x 1"	-
31	15-00307	8	Flat Washer 3/8" / M10 Hardened	-

GROUP 9 - ACCESSORIES & OPTIONAL EQUIPMENT

Low Coolant Level Switch/ Gauge

L - M1064A, D, & T

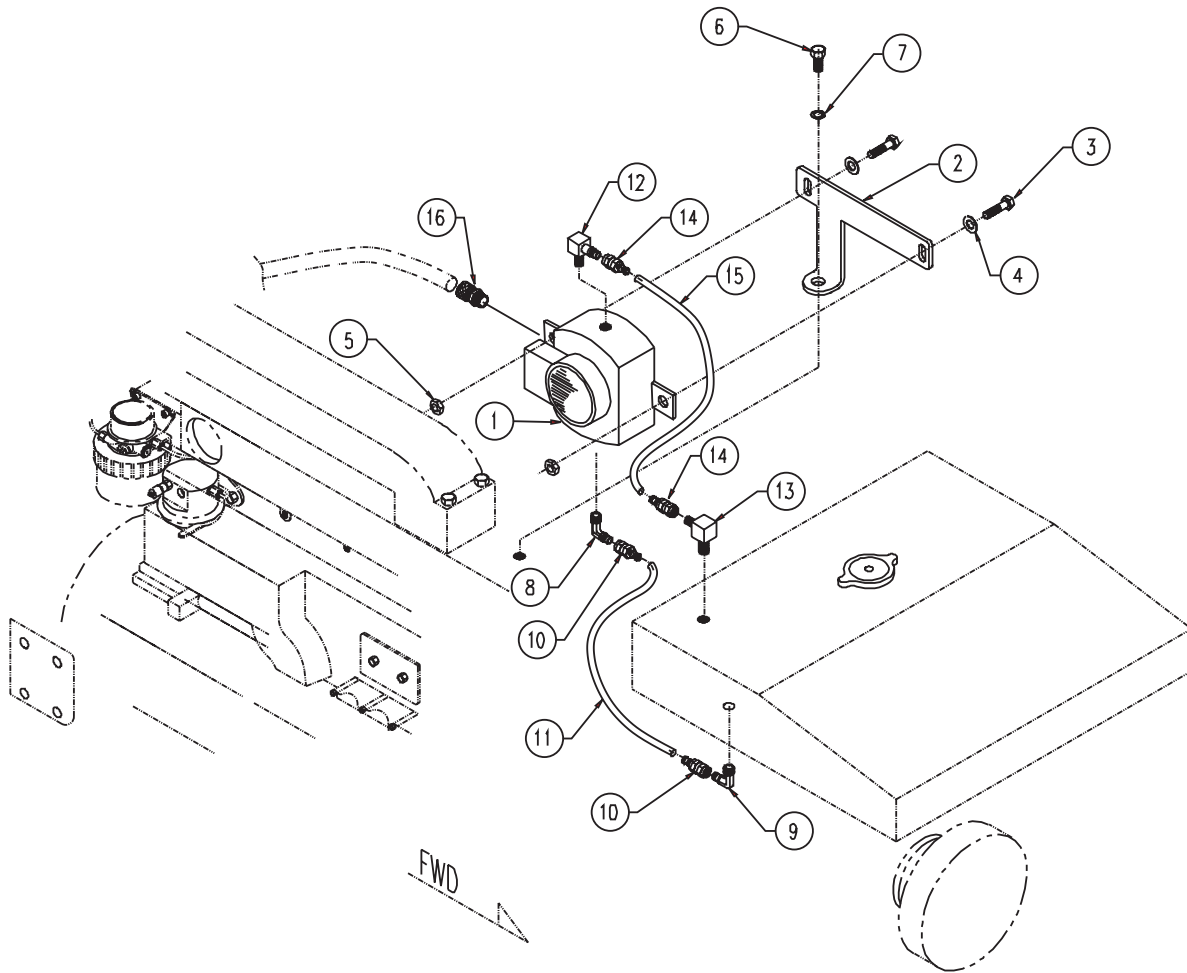

A-8350/ C-4519

KEY	PART NUMBER	QTY	DESCRIPTION	SERIAL NUMBER
1	22-10003	1	Coolant Level Switch/ Gauge (Isolated Ground)	-
2	23-09509	1	Gauge Bracket	-
3	12-00031	2	Capscrew, Hex Head, M6 x 1.0 x 25 mm	-
4	15-00008	2	Flat Washer, M6	-
5	14-04803	2	Hex Nut, Nylock, M6 x 1.0	-
6	12-20913	1	Capscrew, Socket Head, M12 x 1.75 x 30 mm	-
7	15-04802	1	Lock Washer, High Collar, M12	-
8	21-70011	1	Male Elbow, 90°, Steel, 1/2 NPT x 3/8 -37T	-
9	21-00015	1	Male Elbow, 90°, Steel, 1/4 NPT x 3/8 -37T	-
10	21-71034	2	Female Swivel, Brass, 3/8 HB x 3/8-37T, Push-on	-
11	41-01020	10	Hose, 3/8" I.D., Push-on	-
12	21-71044	1	Male Elbow, 90°, Brass, 1/4 NPT x 1/4-45T	-
13	21-71043	1	Male Elbow, 90°, Brass, 1/8 NPT x 1/4-45T	-
14	21-71045	2	Female Swivel, Brass, 3/8 HB x 1/4-45T, Push-on	-
15	41-01011	10	Hose, 1/4" I.D., Push-on	-
16	00-40016	1	Strain Relief Connection, 1/2 NPT	-

Low Coolant Level Switch/ Gauge

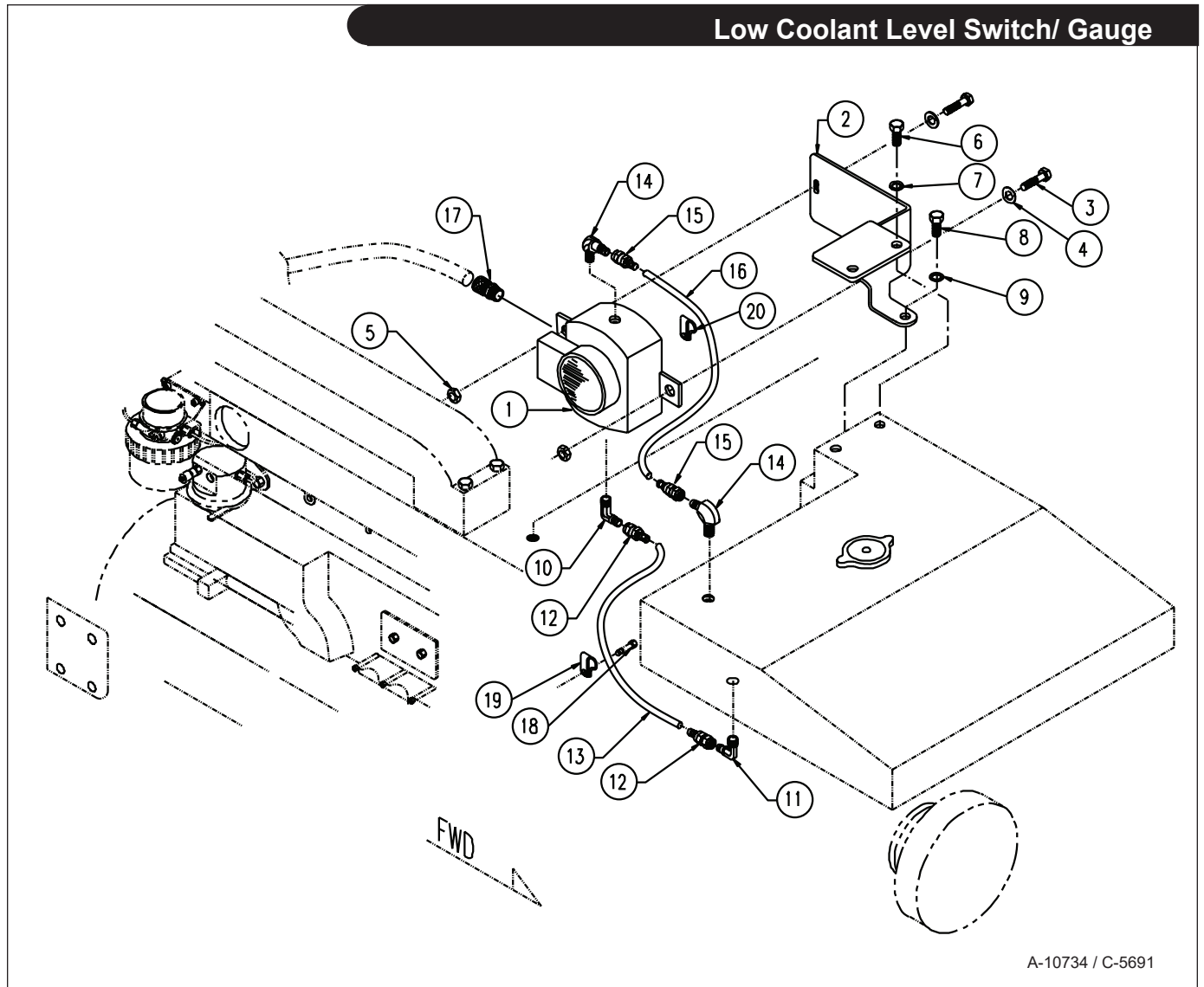

A-10734 / C-5691

KEY	PART NUMBER	QTY	DESCRIPTION	SERIAL NUMBER
1	22-10003	1	Coolant Level Switch/ Gauge (Isolated Ground)	-
2	23-19509	1	Gauge Bracket	-
3	12-00031	2	Capscrew, Hex Head, M6 x 1.0 x 25 mm	-
4	15-00008	2	Flat Washer, M6	-
5	14-04803	2	Hex Nut, Nylock, M6 x 1.0	-
6	12-00214	2	Capscrew, Hex Head 5/16-18 x 1-1/2"	-
7	15-00202	2	Lock Washer, Helical 5/16	-
8	12-00315	1	Capscrew, Hex Head 3/8-16 x 1-3/4"	-
9	15-00302	1	Lock Washer	-
10	21-70011	1	Male Elbow 90° Steel, 1/2 NPT x 3/8-37T	-
11	21-00015	1	Male Elbow 90° Steel, 1/4 NPT x 3/8-37T	-
12	21-71034	2	Female Swivel, Brass 3/8 HB x 3/8-37T	-
13	41-01020	16	Hose, 3/8" ID Push-on	-
14	21-71044	2	Male Elbow 90° Brass 1/4 NPT x 1/4-45T	-
15	21-71045	2	Female Swivel Brass 1/4 HB x 1/4-45T Push-on	-
16	41-01011	18	Hose 1/4" ID Push-on	-
17	00-40016	1	Strain Relief Connection 1/2 NPT	-
18	12-00315	1	Capscrew, Hex Head 3/8-16 x 1-3/4"	-
19	19-41900	1	Adelle Clamp 3/4" ID	-
20	19-43201	1	Adelle Clamp 1/2" ID	-

GROUP 9 - ACCESSORIES & OPTIONAL EQUIPMENT

Raw Water Flow Switch with Dry Exhaust

L - M1064D, M1064T1 & T2

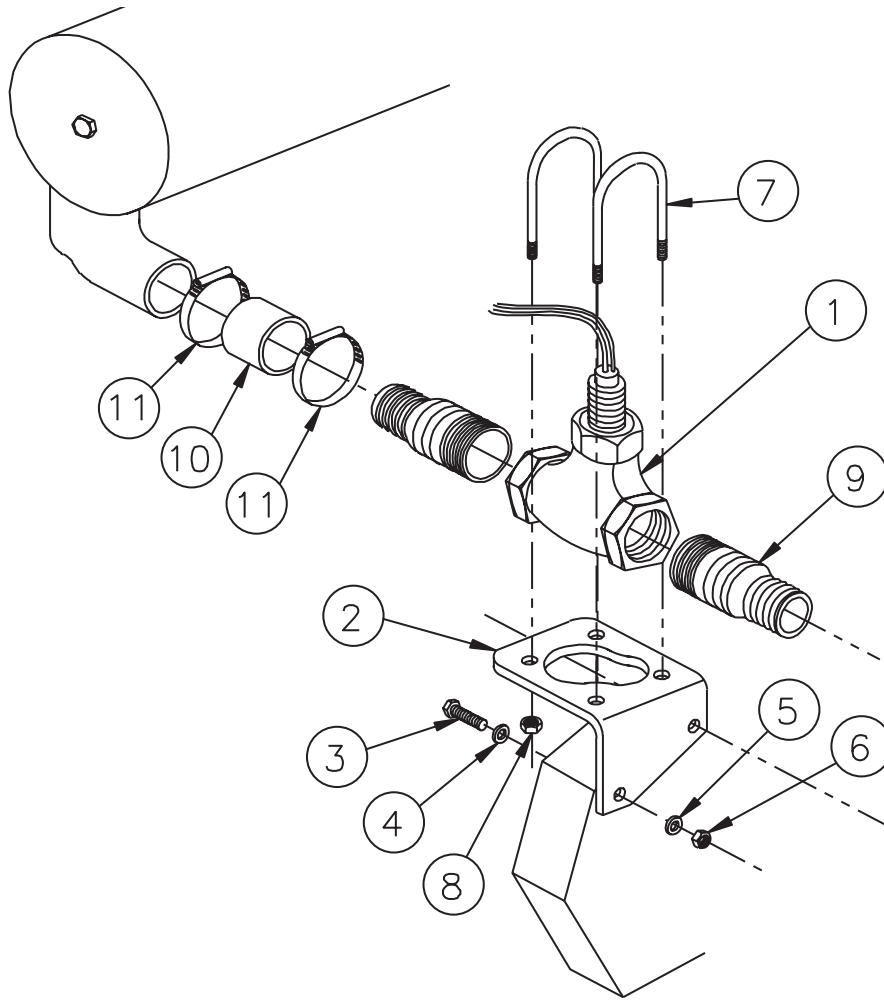

A-9082/ B-8012

KEY	PART NUMBER	QTY	DESCRIPTION	SERIAL NUMBER
1	37-11004	1	Flow Switch 10 GPM 1 -1/4 NPT	-
	37-11006	1	Flow Switch 6 GPM 1 -1/4 NPT (L1064D only)	-
2	23-19501	1	Bracket, Flow Switch Mounting	-
3	12-00716	2	Capscrew, Hex Head M8 x 1.25 x 55 mm	-
4	15-00701	2	Flat Washer M8	-
5	15-00702	2	Lock Washer Helical M8	-
6	14-00711	2	Hex Nut M8 x 1.25	-
7	19-19501	2	U-Bolt 1 -1/2" ID x 3/8 -16 S/S	-
8	14-00302	2	Lock Nut, Plain Flanged 3/8 -16	-
9	21-15017	2	Male Connector Brass 1 -1/4 NPT x 1 -1/4" HB	-
10	18-19501	1	Hose 1 -1/4" ID x 2 -1/2"	-
11	19-01020	2	Hose Clamp #20 Extended Band S/S	-

Raw Water Flow Switch with Wet Exhaust Elbow

L - M1064D & T, Heat Exchanged

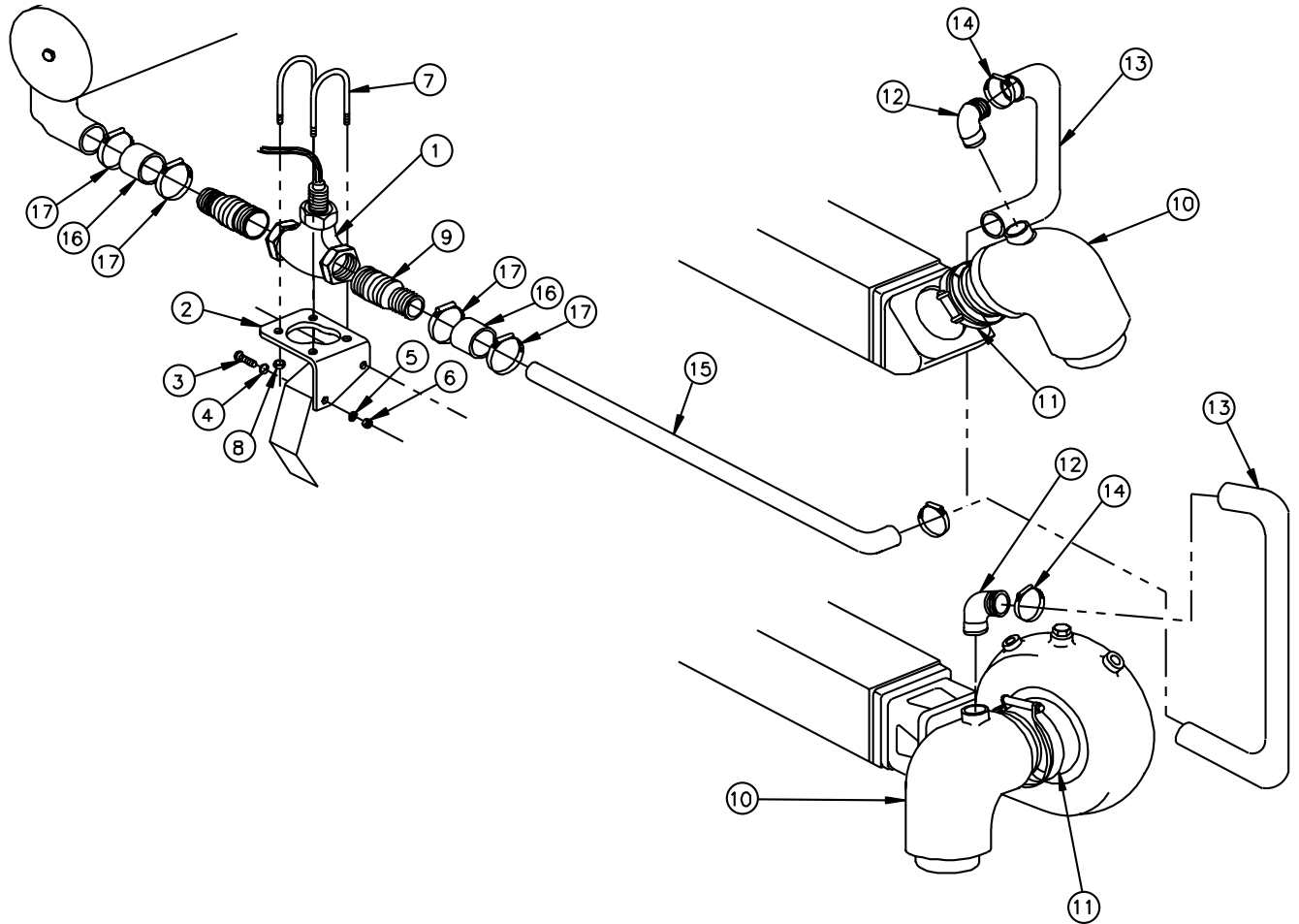

A-8513, A-8515 / B-8014

KEY	PART NUMBER	QTY	DESCRIPTION	SERIAL NUMBER
1	37-11006	1	Flow Switch 6 GPM 1- 1/4 NPT (L1064D only)	-
	37-11004	1	Flow Switch 10 GPM 1- 1/4 NPT (Generator Sets)	-
2	23-19501	1	Bracket, Flow Switch Mounting	-
3	12-00716	2	Capscrew, Hex Head M8 x 1.25 x 55 mm	-
4	15-00701	2	Flat Washer M8	-
5	15-00702	2	Lock Washer Helical M8	-
6	14-00711	2	Hex Nut M8 x 1.25	-
7	19-19501	2	U-Bolt 1 -1/2" ID x 3/8 -16 S/S	-
8	14-00302	4	Lock Nut, Plain Flanged 3/8 -16	-
9	21-15017	2	Male Connector Brass 1 -1/4 NPT x 1 -1/4" HB	-
10	27-31412	1	Elbow, Wet Exhaust 4"	-
11	19-31401	1	V-clamp	-
12	21-31007	1	Male Elbow 90° Copper 1" NPT x 1 -1/4" HB	-
13	41-01070	24	Hose 1 -1/4" ID	-
14	19-00020	4	Hose Clamp #20	-
15	27-19402	1	Tube, Raw Water Discharge 1 -1/4" OD (M1064D)	-
	27-19401	1	Tube, Raw Water Discharge 1 -1/4" OD (M1064T1-T2)	-
16	18-19501	2	Hose 1 -1/4" ID x 2 -1/2"	-
17	19-01020	4	Hose Clamp #20 Extended Band S/S	-

GROUP 9 - ACCESSORIES & OPTIONAL EQUIPMENT

Raw Water Flow Switch

L- M1064A & M1064H

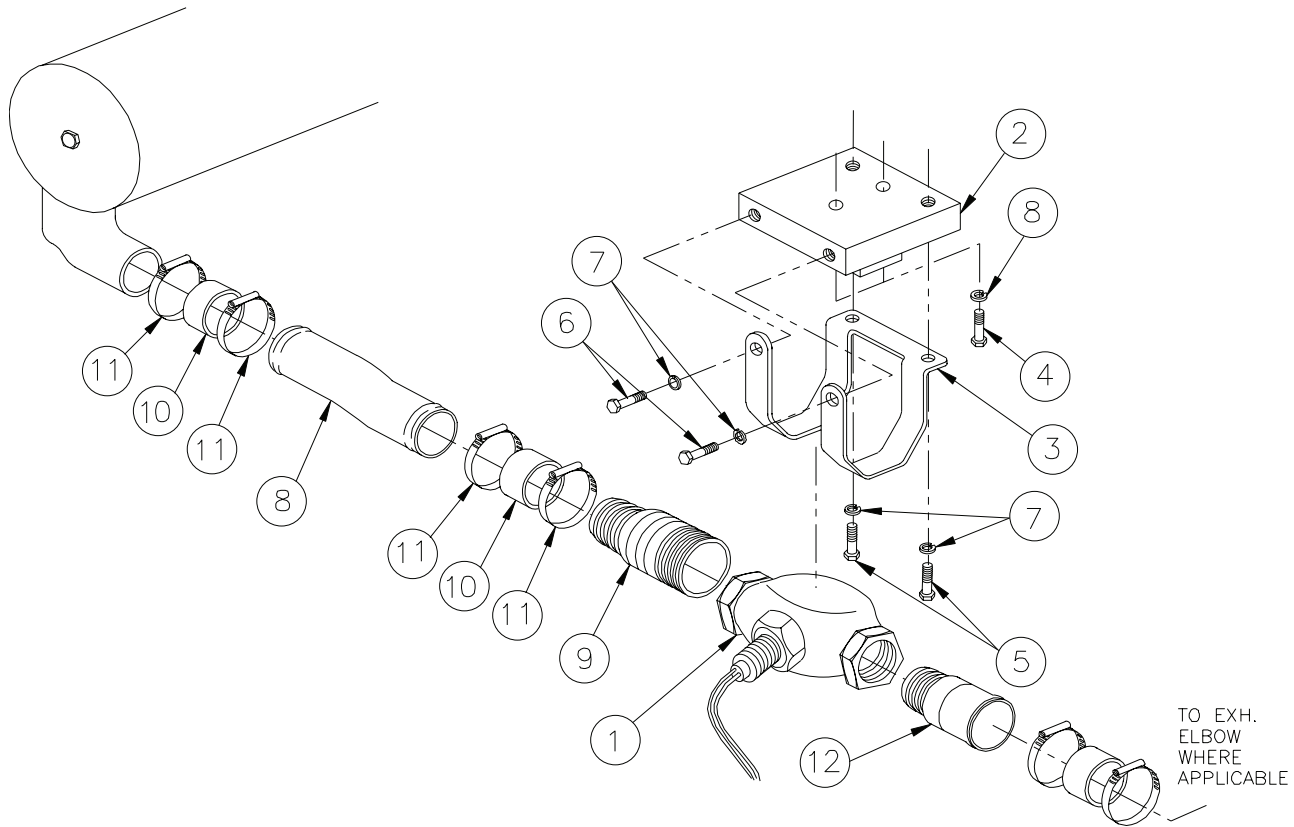

A-10846, A-10848, A-11045, A-10847/ B-8629

KEY	PART NUMBER	QTY	DESCRIPTION	SERIAL NUMBER
1	37-16801	1	Flow Switch, Bronze 10 GPM 2" NPT (L1064A)	-
	37-16802	1	Flow Switch, Bronze 25 GPM 2" NPT (M1064A-H)	-
2	28-19501	1	Plate, 2" Flow Switch Mtg.	-
3	23-19511	1	Clamp, 2" Flow Switch Mtg.	-
4	12-00312	2	Capscrew, Hex Head 3/8-16 x 1"	-
5	12-00311	2	Capscrew, Hex Head 3/8-16 x 3/4"	-
6	12-00311	2	Capscrew, Hex Head 3/8-16 x 3/4"	-
7	15-00302	6	Lock Washer, Helical 3/8	-
8	27-19517	1	Tube, Flow Switch Inlet 2" HB S/S	-
9	21-15029	1	Male Connector, 2" NPT x 2" HB S/S	-
10	18-26002	2	Hose 2" ID x 2-3/4" 4 Ply Silicone	-
11	19-01032	4	Hose Clamp #32	-
12	21-19502	1	Male Connector, Copper 2" NPT x 1-3/4" HB (L1066A-H)	-
	21-15714	1	Male Connector, Copper 2" NPT x 1-5/8" HB (M1066A1,2,3,H)	-

Raw Water Flow Switch, 4" Elbow, Keel Cooled

L1064D and M1064D

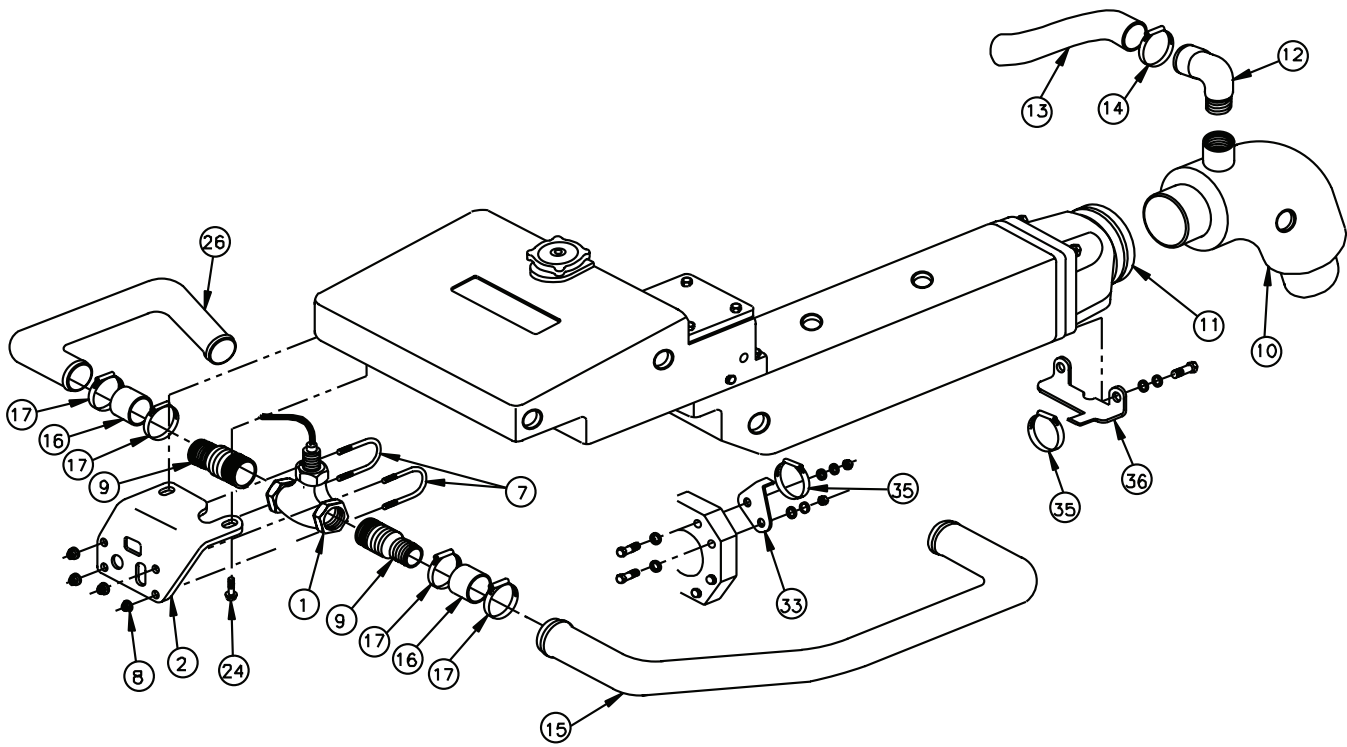

A-10884, A-9344, A-9359/ B-8893

Raw Water Flow Switch, 4" Elbow, Keel Cooled

L1064D and M1064D

KEY	PART NUMBER	QTY	DESCRIPTION	SERIAL NUMBER
1	37-11006	1	Flow Switch 6 GPM 1- 1/4 NPT (L1064D)	-
	37-11004	1	Flow Switch 10 GPM, 1- 1/4 NPT (M1064D)	-
2	23-19504	1	Bracket, Flow Switch Mounting	-
7	19-19501	2	U-Bolt 1 -1/2" I.D. x 3/8 -16 S/S	-
8	14-00302	4	Lock Nut, Plain Flanged 3/8 -16	-
9	21-15017	2	Male Connector Brass 1 -1/4 NPT x 1 -1/4" HB	-
10	27-31412	1	Elbow, Wet Exhaust 4" (Cast Iron)	-
11	19-31401	1	V-clamp	-
12	21-31007	1	Male Elbow, 90° Copper 1" NPT x 1-1/4" HB	-
13	41-01070	20"	Hose 1-1/4" I.D. Wire Reinforced	-
14	19-00020	4	Hose Clamp #20	-
15	27-19404	1	Tube, Raw Water Discharge S/S	-
	27-19403	1	Tube, Raw Water Discharge S/S (M1064D early production)	-
16	18-19501	1	Hose 1 -1/4" I.D. x 2 -1/2" 3 Ply Silicone	-
17	19-01020	2	Hose Clamp #20 Extended Band S/S	-
18	25-19501	1	Raw Water Pump*	-
19	R135101	1	Gear, Raw Water Pump Drive*	-
20	15-19503	1	Shaft Flat Washer M20*	-
24	19M8306	2	Capscrew, Hex Head Flanged M12 x 1.75 x 50 mm*	-
26	27-19502	1	Tube, Raw Water Pump Outlet*	-
27	18-19501	1	Hose, 1- 1/4" ID x 2- 1/2" 3 Ply Silicone*	-
28	19-01020	1	Hose Clamp #20 Extended Band S/S*	-
29	19-71031	1	Adelle Clamp 1- 1/4" I.D. x 1/2" Stud*	-
30	12-00805	1	Capscrew, Hex Head M10 x 1.5 x 20 mm*	-
31	15-00802	1	Lock Washer, Helical M10*	-
32	15-00805	1	Flat Washer, M10*	-
33	23-19505	1	Bracket, Tube Support	-
34	21-42202	1	Spacer	-
35	19-00016	2	Hose Clamp #16	-
36	23-19503	1	Bracket, Tube Support	-
			*Note: See Raw Water Pump Assembly parts detail	

12 & 24 Volt Governor Actuator & Mounting

M1064D

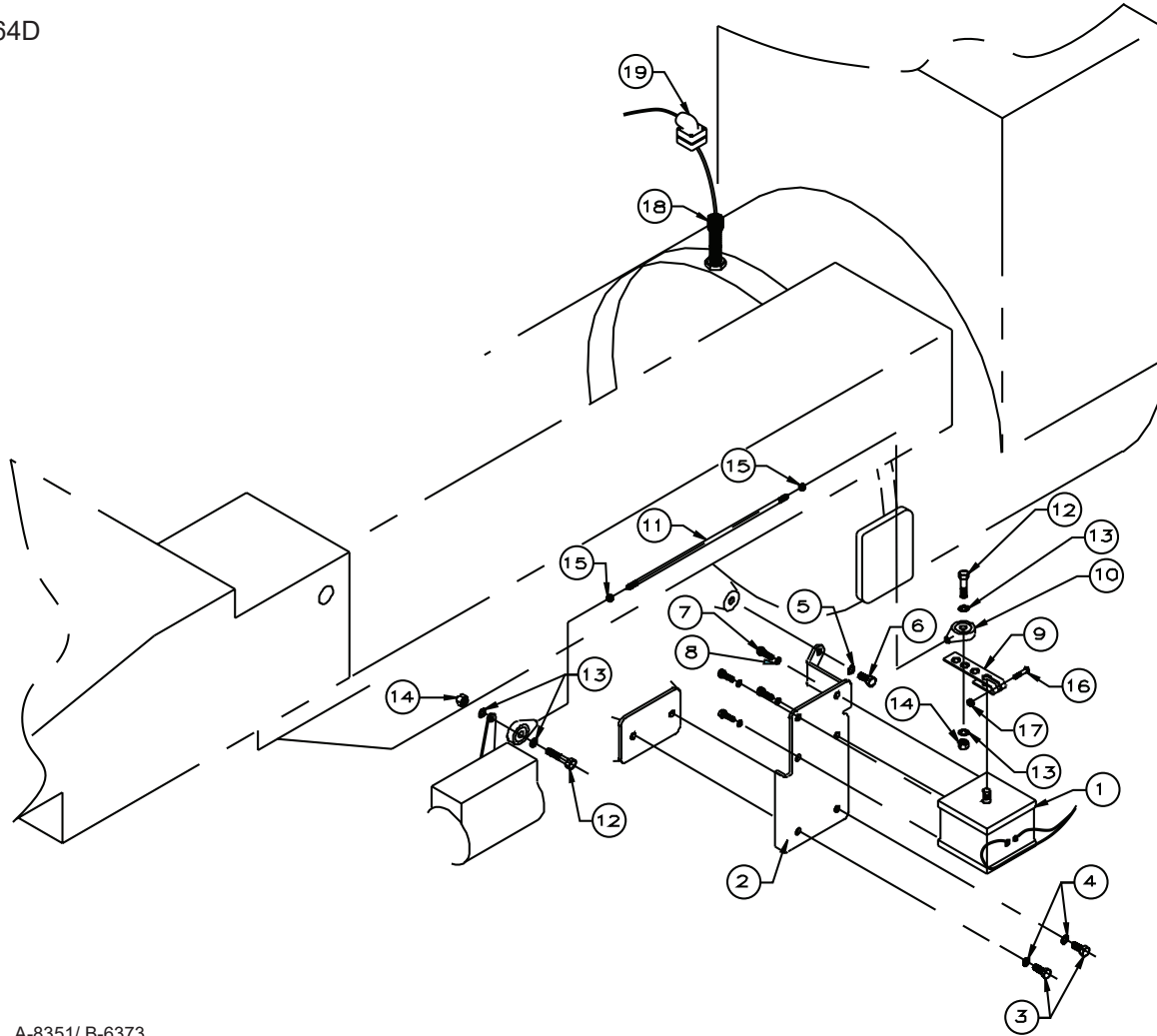

A-8351/ B-6373

KEY	PART NUMBER	QTY	DESCRIPTION	SERIAL NUMBER
1	22-71035	1	Governor Actuator, 12 Volt	-
	22-71037	1	Governor Actuator, 24 Volt	-
2	23-99501	1	Bracket, Governor Actuator Mounting	-
3	12-00753	2	Capscrew, Hex Head, M8 x 1.25 x 30 mm	-
4	15-00702	2	Lock Washer, Helical M8	-
5	12-00831	1	Capscrew, Hex Head, M10 x 1.5 x 25 mm	-
6	15-00802	1	Lock Washer, Helical M10	-
7	12-00111	4	Capscrew, Hex Head, 1/4-20 x 3/4"	-
8	15-00102	4	Lock Washer, Helical 1/4	-
9	23-99502	1	Governor Actuator Lever	-
10	00-99501	2	Rod End, 5/16" I.D. x 5/16 -24	-
11	00-99502	1	Control Rod, 5/16 -24 x 7.76"	-
12	12-00213	2	Capscrew, Hex Head, 5/16-18 x 1 -1/4"	-
13	15-05001	6	Lock Washer, High Collar, 5/16	-
14	14-00212	2	Hex Nut, Nylock 5/16-18	-
15	14-00214	2	Hex Nut, 5/16-24	-
16	12-00113	1	Capscrew, Hex Head, 1/4 -20 x 1 -1/4"	-
17	14-00112	1	Hex Nut, Nylock, 1/4 -20	-
18	22-43208	1	Magnetic Sender, 5/8 -18 x 2 -3/8"	-
19	22-70036	1	Connector Assembly, 90°	-

Electric Clutch and PTO Assembly

H-36 & H-44 Clutches

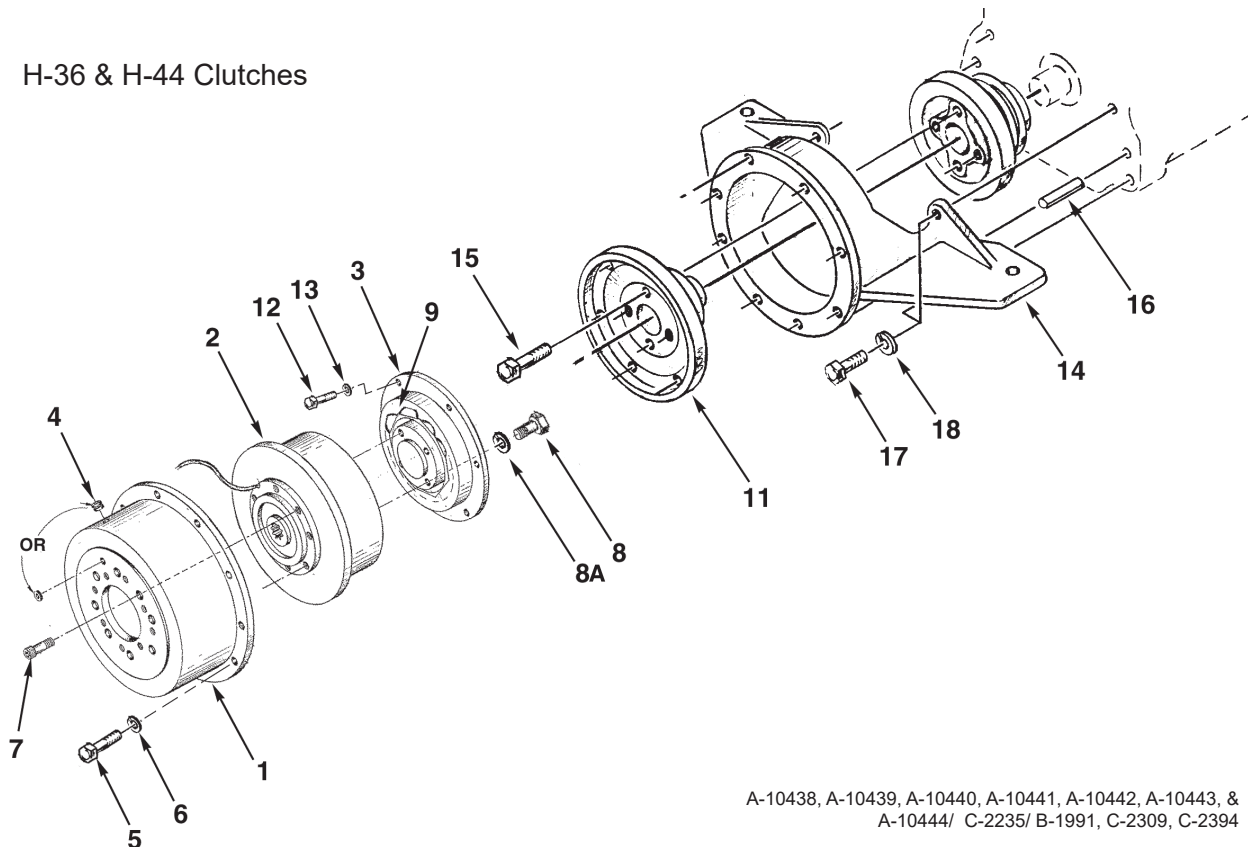

A-10438, A-10439, A-10440, A-10441, A-10442, A-10443, & A-10444/ C-2235/ B-1991, C-2309, C-2394

KEY	PART NUMBER	QTY	DESCRIPTION	SERIAL NUMBER
1	10-60004	1	Housing, B-Pad	-
	10-60003	1	Housing, C-Pad	-
2	34-60020	1	Electric Clutch, H-36 B-Spline 12 Volt	-
	34-60018	1	Electric Clutch, H-36 C-Spline 12 Volt	-
	34-60028	1	Electric Clutch, H-36 B-Spline 24 Volt	-
	34-60027	1	Electric Clutch, H-36 C-Spline 24 Volt	-
	34-60036	1	Electric Clutch, H-44 C-Spline 12 Volt	-
	34-60037	1	Electric Clutch, H-44 C-Spline 24 Volt	-
3	34-69512	1	Drive Assembly (includes keys 9) Former #34-61455	-
4	00-61003	1	Grommet	-
5	12-63100	8	Capscrew, Socket Head, 3/8 -16 x 1"	-
6	15-00321	8	Flat Washer, 3/8 SAE	-
7	12-00035	8	Capscrew, Socket Head, 3/8 -16 x 3/4"	-
8	12-60001	4	Capscrew, Hex Head, 7/16 -20 x 1 -3/4"	-
8a	15-00404	4	Flat Washer SAE 7/16	-
9	00-61001	**	Drive Block	-
11	34-69401	1	PTO Carrier, SAE #8	-
12	12-00312	6	Capscrew, Hex Head, 3/8 -16 x 1"	-
13	15-00301	6	Flat Washer, 3/8	-
14	23-71001	1	Bracket, SAE #5	-
15	19M8162	6	Capscrew, Hex Head Flanged M10 x 1.5 x 40 mm	-
16	32-81001	2	Dowel Pin	-
17	12-04803	4	Capscrew, Hex Head M16 x 2.0 x 40 mm	-
18	15-01000	4	Lock Washer, Helical M16	-
19	00-46025	1	Plug 1/2" Black Nylon	-
			**As required	

GROUP 9 - ACCESSORIES & OPTIONAL EQUIPMENT

Electric Clutch and PTO Assembly

MMC-60 & MMC-100 Clutches

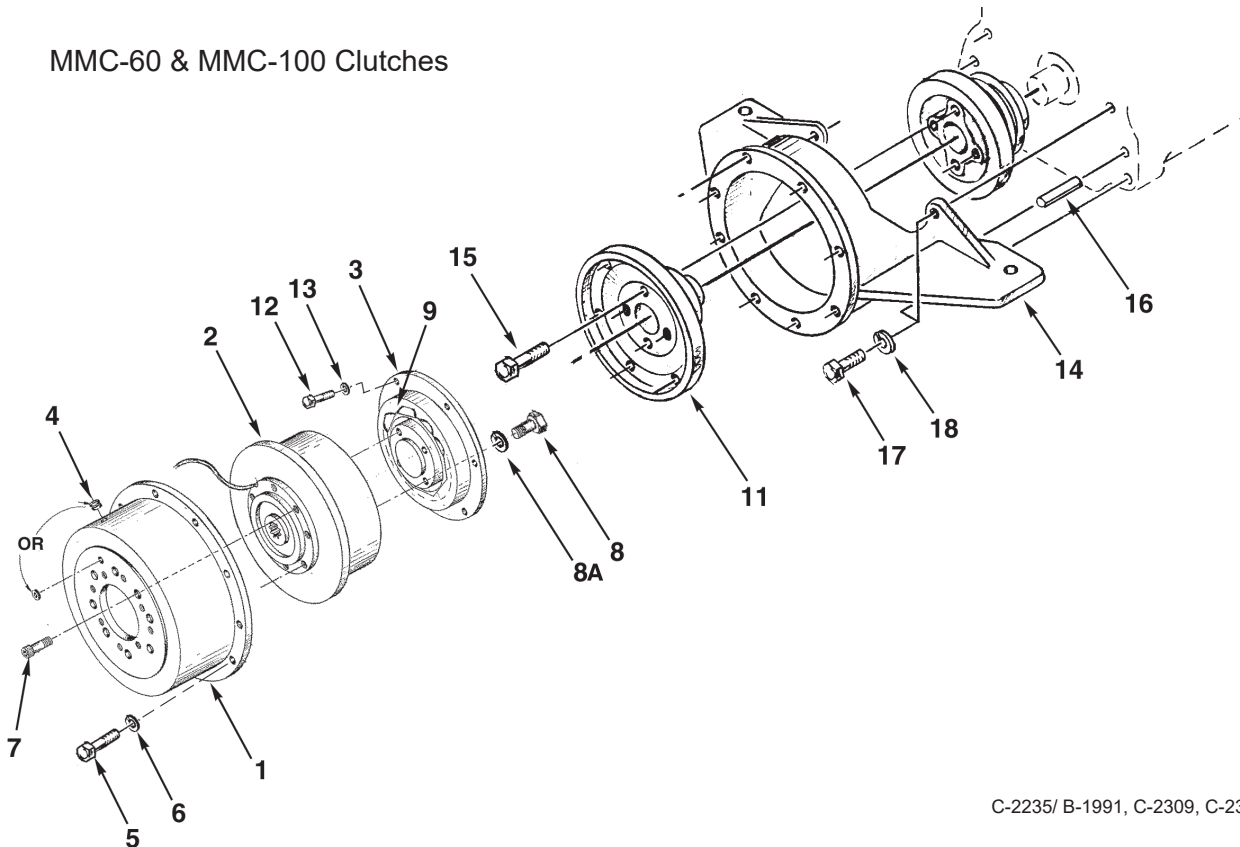

C-2235/ B-1991, C-2309, C-2394

KEY	PART NUMBER	QTY	DESCRIPTION	SERIAL NUMBER
1	10-60003	1	Housing, C-Pad MMC-60	-
	10-60016	1	Housing, C-Pad MMC-100	-
2	34-60083	1	Electric Clutch, MMC-60 C-Spline 12 Volt	-
	34-60084	1	Electric Clutch, MMC-60 B-Spline 24 Volt	-
	34-60097	1	Electric Clutch, MMC-100 C-Spline 12 Volt	-
	34-60098	1	Electric Clutch, MMC-100 C-Spline 24 Volt	-
3	34-69512	1	Drive Assembly (includes keys 9) MMC-60	-
	34-69517	1	Drive Assembly (includes keys 9) MMC-100	-
4	00-61003	1	Grommet	-
5	12-63100	8	Capscrew, Socket Head, 3/8 -16 x 1"	-
6	15-00321	8	Flat Washer, 3/8 SAE	-
7	12-00035	8	Capscrew, Socket Head, 3/8 -16 x 3/4"	-
8	12-60001	4	Capscrew, Hex Head, 7/16 -20 x 1 -3/4" (Use with 34-69512)	-
	12-50413	5	Capscrew, Hex Head, 7/16-20 x 1 -1/4" (Use with 34-69517)	-
8a	15-00404	4	Flat Washer SAE 7/16	-
9	00-61001	**	Drive Block	-
11	34-69401	1	PTO Carrier, SAE #8	-
12	12-00312	6	Capscrew, Hex Head, 3/8 -16 x 1"	-
13	15-00301	6	Flat Washer, 3/8	-
14	23-71001	1	Bracket, SAE #5	-
15	19M8162	6	Capscrew, Hex Head Flanged M10 x 1.5 x 40 mm	-
16	32-81001	2	Dowel Pin	-
17	12-04803	4	Capscrew, Hex Head M16 x 2.0 x 40 mm	-
18	15-01000	4	Lock Washer, Helical M16	-
19	00-46025	1	Plug 1/2" Black Nylon (not shown)	-
			**As required	



4420 14th Ave. NW., Seattle WA 98107

Tel: (206) 789-3880 • 1-800-762-0165 • www.northern-lights.com

Northern Lights and Lugger are registered trademarks of Northern Lights, Inc.

© 2017 All rights reserved. Litho USA.